



Dewatering Pumps

Electrical & DC Powered | Engine Driven



Table of Contents

	Page
General Information.....	2-3

Electric & DC Powered

Mini Mac Transfer Pump Kit.....	4-5
Handymac	6
115V Submersible Pumps	7
Submersible SludgeMaster Air-Powered Pump	8-9
Cast Iron Sewage & Trash Pumps	10-11

Engine Driven General Purpose

Thermoplastic.....	12-13
--------------------	-------

High Pressure

Die-Cast Aluminum.....	14-15
------------------------	-------

Engine Driven

Trash Pumps

2" & 3" Trash Pump	16-17
3" & 4" Trash Pumps.....	18-21
6" Engine Driven Trash Pumps	22-23

Dredging Pump

2" Dredging Pump.....	24-25
-----------------------	-------

Diaphragm Pumps

Self-Priming Diaphragm Pumps.....	26-27
-----------------------------------	-------

Fire Pumps

Fire Pumps	28-29
------------------	-------

Well-equipped.



Founded more than 156 years ago, A.Y. McDonald Mfg. Co. is the only remaining family-owned business in the industry. We have a proud tradition of providing quality water pumps and submersible pumps to professional installers — and exceptional customer support to back them up.

Choose A.Y. McDonald for:

- Friendly, responsive, dedicated customer service specialists
- Hand-assembled products built exclusively for professional installation
- Application-specific solutions to meet your needs as an installer
- Comprehensive product warranty program

Visit aymcdonald.com to learn more about our quality product lines, dependable customer service, and more than 156 years of industry-leading expertise.



More than a brand. We're a family.

aymcdonald.com ◆ 1-800-292-2737 ◆ sales@aymcdonald.com

How to Order Dewatering Pumps

Order by Model Number. Example: 02G3AC

02

Intake & Discharge Size
 01.5 - 1 1/2"
 02 - 2"
 03 - 3"
 04 - 4"
 06 - 6"

G

Type
G - General Dewatering
P - High Pressure
S - Trash
D - Diaphragm
J - Dredging
F - Fire Pump

3

Horsepower
 1/3 HP 6 1/2 HP
 1/2 HP 7 1/2 HP
 1 HP 8 HP
 1 1/2 HP 9 HP
 2 1/2 HP 10 HP
 3 HP 13 HP
 3 1/2 HP 24 HP
 5 HP 27 HP
 5 1/2 HP

A

Motor Type
A - Briggs & Stratton Intec Plus *
H - Honda Engine
I - Briggs & Stratton Industrial Engine
Y - Yanmar Diesel
K - Kohler
D - Deutz Diesel
J - John Deere
Z - Hatz Diesel

C

Construction Materials or Accessories
B - BSPT threads on suction and discharge
C - Cast Iron
K - Impeller for keyed shaft (kits only)
T - Thermoplastic
R - Roll Cage
V - Electric or Electric Start
P - Premium
X - Die-cast aluminum

* 3 1/2 HP & below are standard Briggs & Stratton engines

Note: For engine driven models, HP class represents market category and is not intended to define actual horsepower.

6" Engine Trash Pumps

T - Trailer Mounted for 6"
S - Skid Mounted for 6"



Mini Mac - Transfer Pump Kits

The mini mac transfer pump kit can handle most domestic and commercial pump requirements. With a durable cast brass and stainless steel construction this pump is designed for long life and can withstand temperatures ranging from 40° to 130°F.

Applications

Emptying water heaters, bilge pumping, bait tanks, liquid transfer, clogged sinks, dewatering, and any common small household job.

*Medium being pumped must be compatible with pump materials.
Not for use with flammable liquids.

Features

- Buna N impeller and lip seal
- Inlet and outlet are 3/4" male garden hose
- Self priming to 7 feet
- Available 115V AC



300611TPK Dimensions | 115V AC 3/4" Garden Hose Threads External

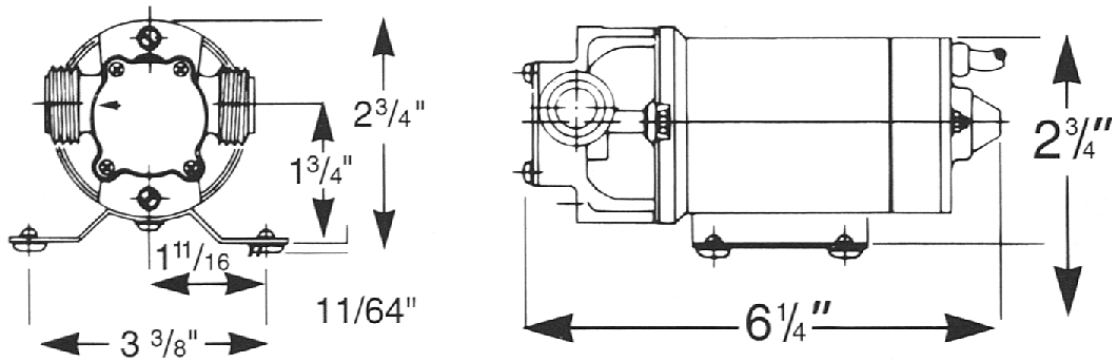

Model Includes:



Replacement impeller

Puddle scoop and 6' suction hose for draining flat surfaces

*To purchase impeller replacement separately, order # 300622RK.

Mini Mac - Transfer Pump Kits

Specifications for Flexible Impeller Transfer Pump

Specifications

Power supply required	115V 60 Hz	Impeller & lip seal	Nitrile
Motor, full load amps (fuse size)	2.0 Amps	Lip seal metal retain	BL 22
Motor type (design)	Universal	Motor shaft material	416 S.S.
Motor leads and length	6' Cord	Ports	3/4" external hose, Thread suction & discharge
HP	1/6	Pump gasket	Paper
Dimensions (overall) not include base	6 1/4" L x 3 1/2" H x 3 1/4" W	Cover	316 S.S.
Maximum liquid temperature	130°F	Screws	18-8 S.S.
Minimum	40°F	Slinger	Neoprene
Pump body material	Environmental Safe, No-Lead Alloy	Shipping weight	6 lbs.

Note: Specifications subject to change without notice.

Performances

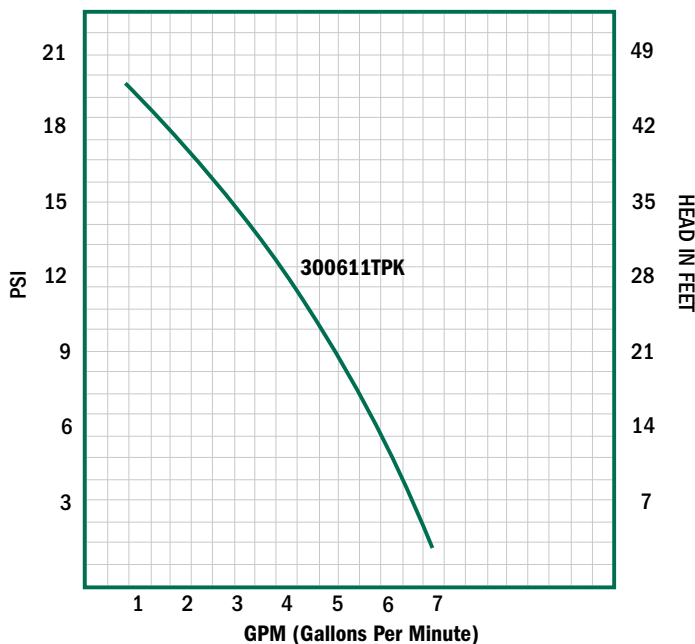

Performance (GPH)

Model	1 FT.	5 FT.	10 FT.	15 FT.	20 FT.	30 FT.	40 FT.	Shut-Off
300611TPK	400	390	358	330	295	225	120	48 FT.

303022SP - Handymac

The powerful and portable Handymac can operate on any 12-volt truck or automobile battery. A convenient 30' cable is standard. An optional carrying case is also available.

Applications

Dewatering applications for utility companies, contractors, municipalities, and industrial users.

Features

- 1/3 HP motor delivers up to 43 GPM
- Remote waterproof controller integrated into the pump cable for simple safe operation
- Unit weighs just 33 lbs
- Low, 30 amp draw for approximately an hour of operation without restarting the engine (times may vary)
- Watertight o-ring seals keep pump internals dry
- Color coded battery power leads
- Self-lubricating shaft seals, and bearing lubricated for long life
- 1 1/2" NPT discharge pipe size



Improved switch design for increased reliability

Performance

Capacity	Discharge Height
41.6 GPM	5'
34.0 GPM	10'
25.0 GPM	15'
21.3 GPM	20'
0.0 GPM	25'

Important

1. Make sure the vehicle and the pump are not in contact during connection.
2. Do not run completely dry for extended periods. Damage to shaft seal may result.
3. Do not use power cable for handling unit.

Danger

Turn off before connecting battery clamps to battery. Arcing could result. Not for use with fluids that have a flash point below 100°F/ 38°C (examples: gasoline, alcohol). Sparking could result in death.

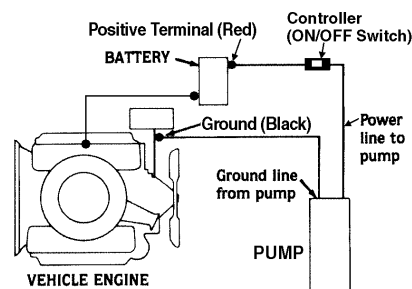

Optional storage / carrying case

This is available to protect the pump during between-jobs storage and on truck or in field during transit. Welded steel construction, carrying handle, lock-type center hasp and identification sign. Hammered paint finish.

10" wide, 24" long, 11" high.

Order Model No. 303022B for Carrying Case



Submersible Pumps - 115V

With their slim-design, these light weight submersibles feature top discharge as well as cast-iron impellers, 304 stainless steel casing, motor housing, shaft, and hardware. The pump motor is protected by overload of thermal breaker. These are rugged and durable submersible pumps at value prices and can be used with piggyback float switches.

Applications

Dewatering applications for utility companies, contractors, municipalities, and industrial users.

Features

- 1 1/2 inch and 2 inch Pumps, 1/3 HP to 1 HP
- Stainless steel / Cast iron construction
- Light weight slim design
- Motors thermal overload protected
- Lower seal: silicon - carbide, viton
- Upper seal: carbon - ceramic, viton
- Oil lubricated seals
- Cast iron impeller, top, pump end
- 304 stainless steel casing, motor housing, shaft, and hardware
- Long power cables - 30' on 1/3 HP & 1/2 HP, and 50' on 1 HP
- Pumps cannot run dry



Dimensions

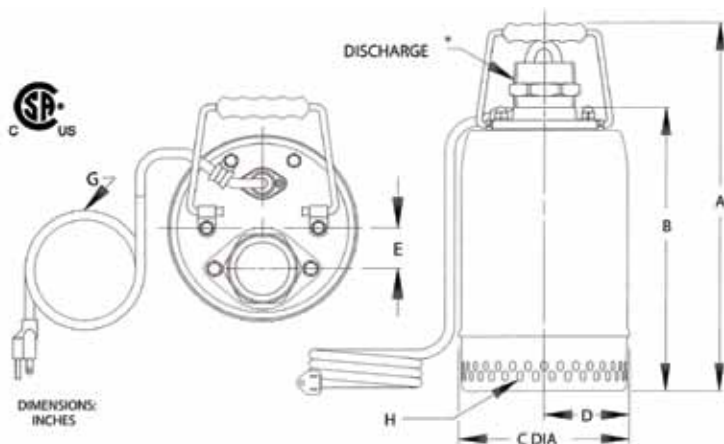

Submersible Pump Performance Curve

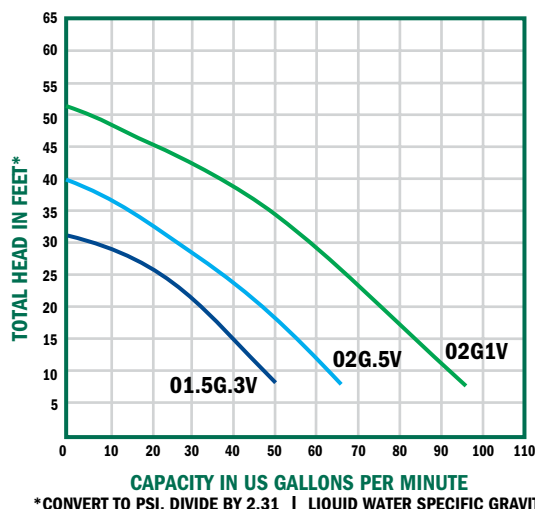

Model No.	A	B	C	D	E	Disch*	G Cable Length	H Suction Strainer	HP	Discharge	FL Amps	VAC or Tank Size (Qts.)	Ship Wt. (lbs)
01.5G.3V	14.50	11.25	6.66	3.33	1.44	1.50	30.00 FT	.39 X .24 SLOTS ON STAGGERED CENTER	1/3 HP	1.5"	2.8	115V	30
02G.5V	14.50	11.13	6.66	3.33	1.44	2.00	30.00 FT	.39 X .24 SLOTS ON STAGGERED CENTER	1/2 HP	2"	5.4	115V	31
02G.1V	17.12	13.75	7.55	3.80	1.64	2.00	50.00 FT	.25 X .38 SLOTS ON STAGGERED CENTER	1 HP	2"	9.3	115V	50

(*) Standard NPT (male) pipe thread.

WARNING: Do not use in explosive atmosphere or for pumping volatile flammable liquids.

325070SL - SludgeMaster

The benefits of air-powered SludgeMaster are varied and unique. Immediate use: simply hook up compressed air supply, lower through manhole or into sump or fluid to be pumped. No fuel tanks to run empty, no gas cans to carry, no electrical connections, no electric motors to overload. High capacity, low head operation to meet nearly every emergency or daily-use application. Keeps pumping without clogging on most problem jobs. Won't choke up on small trash. Can run dry with no damage. Self-draining to prevent damage in below-freezing weather. Sturdily built for rough handling and long-life endurance on land, at sea or offshore: cast iron & steel for wear, aluminum for weight-saving.

Applications

- Handles mud, leaves, twigs, sand, sludge, mill-scale, bilge-gunk, sewage and trash-laden water typically confronted by utility companies, contractors, municipalities, and most industries.
- Also handles most substances common to the chemical process, marine, mining, paper pulp and petrochemical industries . . . even handles small solids.

Features

- Powered by a compressed air powered motor with easily adjusted variable flow and pressure control.
- Up to 65' shut-off head.
- Self-priming. Submersible when exhaust air is piped above surface. No suction hose needed.
- Weighs just 59 lbs. Only 23" high. Air inlet 1/2" NPT.
- Fits through openings as small as 14" diameter.
- Fool-proof design: open two-vane low-speed trash-type cast iron impeller handles abrasive substances with less wear.
- Continuous automatic lubrication: internal oiler, oil-bath lubricated shaft seal; needs only 1 pint every 50 hours of use.
- Built-in speed-limiting governor prevents damage to pump if run dry for extended periods of time.



Discharge Pipe Size
3"

Capacity
Up to 300 GPM

325070SL - SludgeMaster

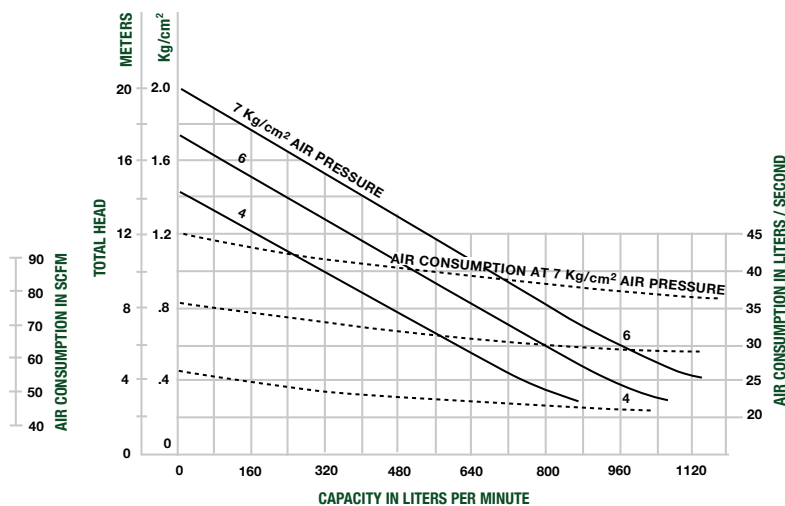
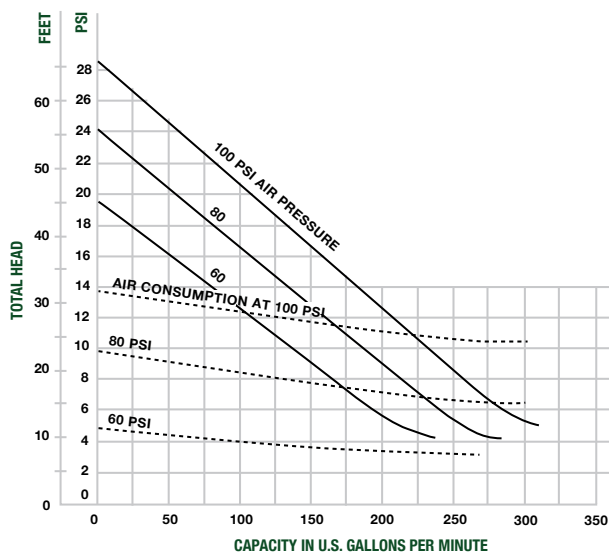
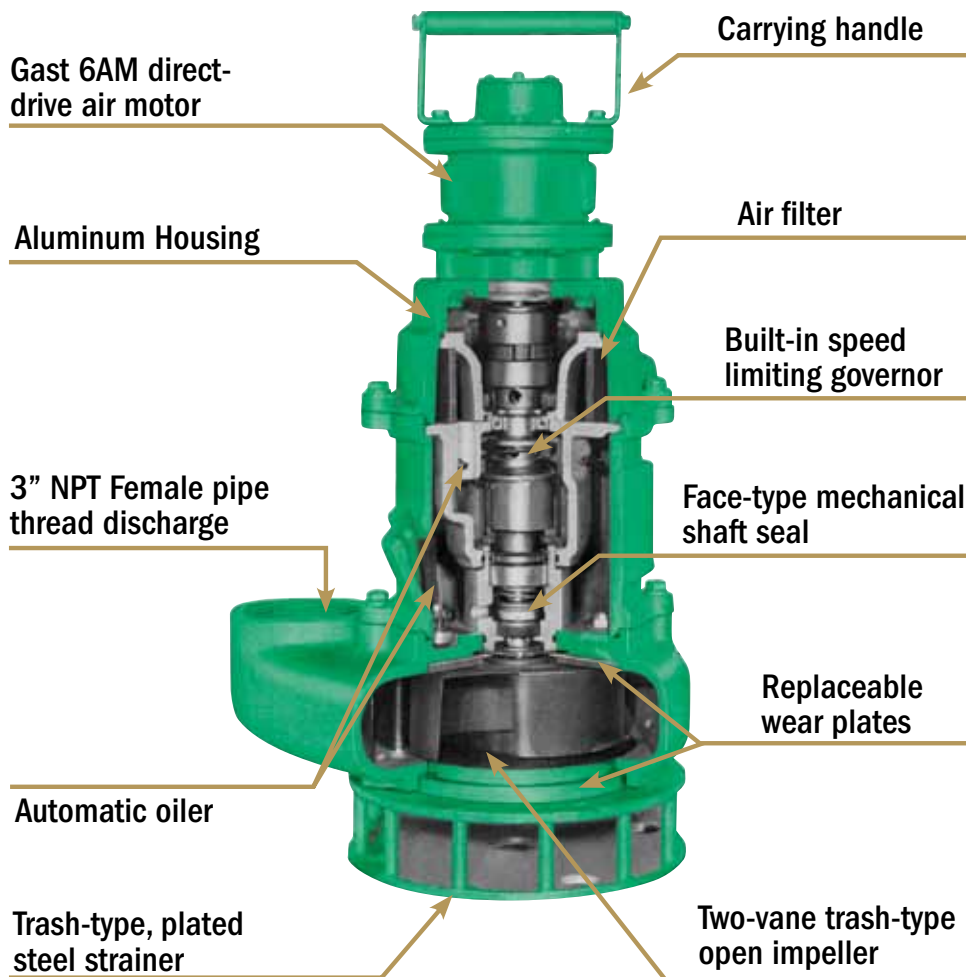

Cast Iron Sewage | Trash Pumps

A.Y. McDonald cast iron sewage/trash pumps are designed for trouble free and economical handling of solid laden liquids and slurries. Pumps are available in three NPT port sizes; 2", 3", and 4". Cast iron construction with two vane stainless steel self-cleaning impellers, silicon carbide mechanical seals for abrasion resistance and Buna-N o-rings and check valves. Built-in check valve allows pump to reprime automatically in an open system, without a foot valve.

A.Y. McDonald Sewage/Trash pumps will easily handle liquids containing sewage, stone, sticks, mud, and other solids. Minimum liquid requirement must be above 85%. Failure to do so may damage pump and void warranty. These pumps are reliable, cost effective, and low maintenance. For use with non-flammable liquids which are compatible with pump component materials.

Applications

The solids handling capabilities of the pumps make them ideally suited for a variety of industrial applications including: sewage treatment, canneries, chemical processing, wineries, tanneries, meat packing, breweries, pulp, wood chips, process water, sludge and slime, waste water, white water, and other applications.

Features

- Cast iron construction
- Silicon carbide/viton mechanical seal
- 2", 3", & 4" NPT port sizes
- Self-priming up to 20'
- Maximum temperature 180°F
- Maximum working pressure 150 PSI
- Stainless steel semi-open, clog resistant impeller
- Built in Buna-N check valve
- Removable cast iron volute/wearplate
- Easy cleanout design
- Pull-from-rear design
- 3" & 4" models feature front cleanout
- Available with 3 to 15 HP totally enclosed fan cooled (TEFC) electric motors
- Single and three phase, 3450 RPM Motors
- Seal flush port provided on 5 HP and larger



Sewage & Trash Pump Performance Curves

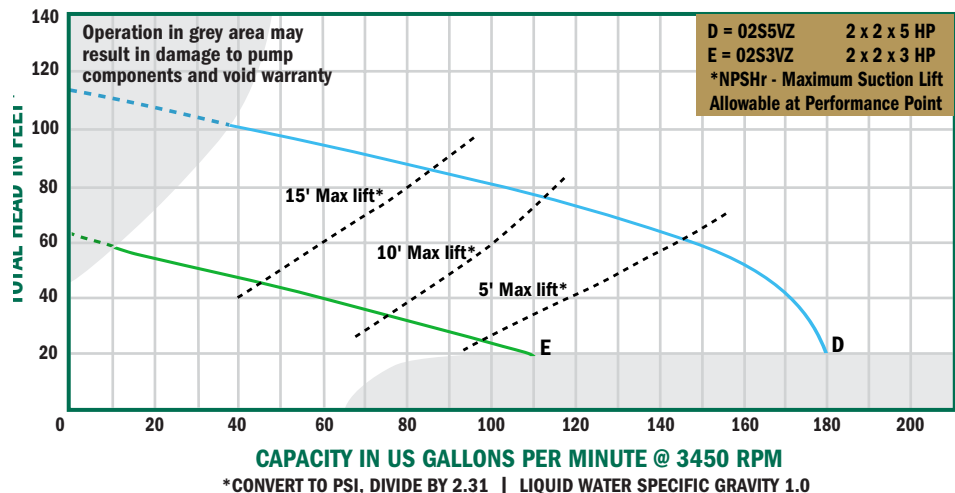
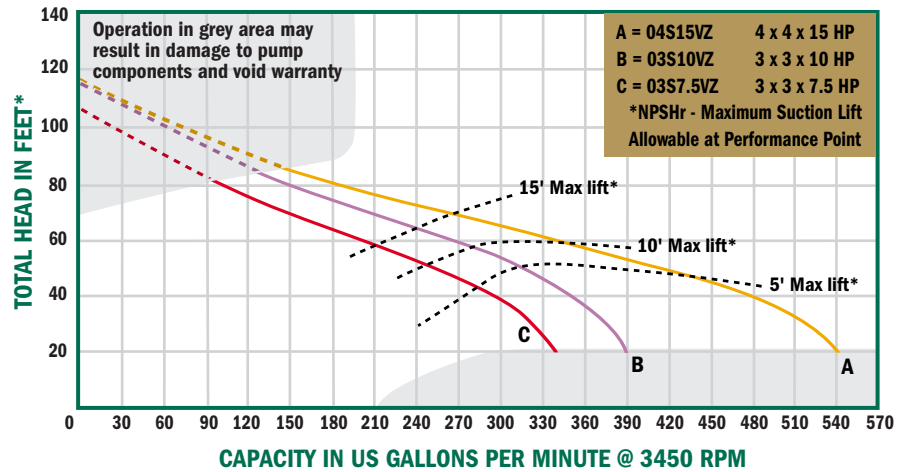

Cast Iron Sewage | Trash Pumps

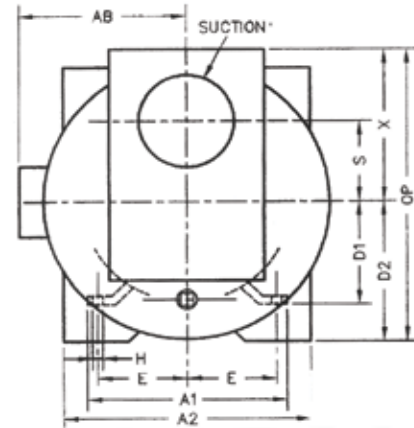
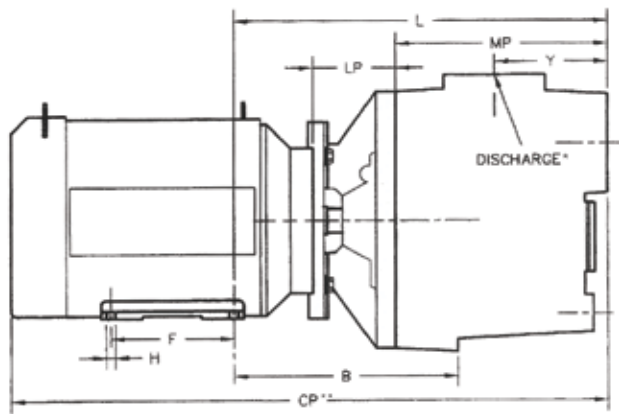

Dimensions

Model No.	HP	SUC*	DIS*	CP**	A1	Width	AB	B	D1	D2	E	F	H	L	LP	MP	OP	S	X	Y
02S3VZ	3	2"	2"	21.0	6.5	9.0	5.0	N/A	3.5	N/A	2.4	3.0	0.88 X 0.34	11.0	2.3	6.1	8.2	2.1	4.7	3.1
02S3V	3	2"	2"	21.0	6.5	9.0	5.0	N/A	3.5	N/A	2.4	3.0	0.88 X 0.34	11.0	2.3	6.1	8.2	2.1	4.7	3.1
02S5VZ	5	2"	2"	25.0	6.4	13.5	8.6	9.7	4.5	5.2	3.7	5.5	0.4	14.8	4.4	6.9	10.	2.1	4.7	3.1
02S5V	5	2"	2"	25.0	6.4	13.5	8.6	9.7	4.5	5.2	3.7	5.5	0.4	14.8	4.4	6.9	10.	2.1	4.7	3.1
03S7.5VZ	7.5	3"	3"	26.5	6.4	15.5	9.4	10.0	4.5	5.7	3.7	5.5	0.4	16.5	3.7	9.3	12.4	3.5	6.6	5.0
03S7.5V	7.5	3"	3"	31.0	9.5	15.5	9.4	10.8	5.2	5.7	4.2	7.0	0.4	17.4	3.7	9.3	12.4	3.5	6.6	5.0
03S10VZ	10	3"	3"	31.0	9.5	15.5	9.5	10.8	5.2	5.7	4.2	7.0	0.4	17.4	3.7	9.3	12.4	3.5	6.6	5.0
03S10V	10	3"	3"	31.0	9.5	15.5	9.5	10.8	5.2	5.7	4.2	7.0	0.4	17.4	3.7	9.3	12.4	3.5	6.6	5.0
04S15VZ	15	4"	4"	32.0	9.5	15.5	9.5	11.2	5.2	6.1	4.2	7.0	0.4	18.5	3.7	10.3	14.3	3.5	8.1	6.6

(*) Standard NPT (female) pipe thread.

(**) This dimension may vary due to motor manufacturer's specifications.

(+) 3-Phase motors can operate on 50 Hz. (Those will change Full Load Amps, Service Factor, RPM and Priming Capabilities)

NOTE: Dimensions have a tolerance of $\pm 1/8"$.

NOTE: Electric supply for ALL motors must be within $\pm 10%$ of nameplate voltage rating (Ex. 230V $\pm 10%$ = 207 to 253)

Specification

Model No.	HP	Phase	ENC	Frame	Voltage @60 Hz+	Full Load Amps	Max Solids	Ship Wt.
02S3VZ	3	3	TEFC	56J	230/460	8/4	1"	87 lbs
02S3V	3	1	TEFC	56J	230	16	1"	94 lbs
02S5VZ	5	3	TEFC	184JM	230/460	17/9	1"	146 lbs
02S5V	5	1	TEFC	184JM	230	20	1"	170 lbs
03S7.5VZ	7-1/2	3	TEFC	184JM	230/460	22/11	1-1/2"	200 lbs
03S7.5V	7-1/2	1	TEFC	215JM	230	31	1-1/2"	255 lbs
03S10VZ	10	3	TEFC	215JM	230/460	26/13	1-1/2"	215 lbs
03S10V	10	1	TEFC	215JM	230	40	1-1/2"	285 lbs
04S15VZ	15	3	TEFC	215JM	230/460	47/24	2"	287 lbs

Cast Iron | Thermoplastic

The A.Y. McDonald line of engine driven dewatering pumps offer economy, durability, portability and performance all in one neat package. Pump construction materials range from cast iron featuring dual volute design that reduces radial load on engine to corrosion resistant thermoplastic components featuring removable/replaceable volutes, impellers and wearplates. A.Y. McDonald Engine Driven Dewatering pumps are reliable, cost effective, and low maintenance.

Applications

Ideal for general purpose dewatering, irrigation, spraying, washdown, and agricultural applications. For use with non-flammable liquids which are compatible with pump component materials.

Features

- Cast iron or thermoplastic construction
- Briggs & Stratton or Honda engines
- Buna-N mechanical seal
- 2" NPT port sizes
- Self-priming up to 20'
- Semi-open, clog resistant impellers
- Available in 3 1/2 and 5 1/2 HP engines
- Pumps include carrying handle
- Solids Handling - 3/8" - 7/16" diameter
- Built-in flapper / check valve
- Two NPT pipe nipples
- Maximum working pressure 60 psi



2" Dewatering pump
Cast iron housing



2" Thermoplastic housing

Engine Driven Pump Performance Curves

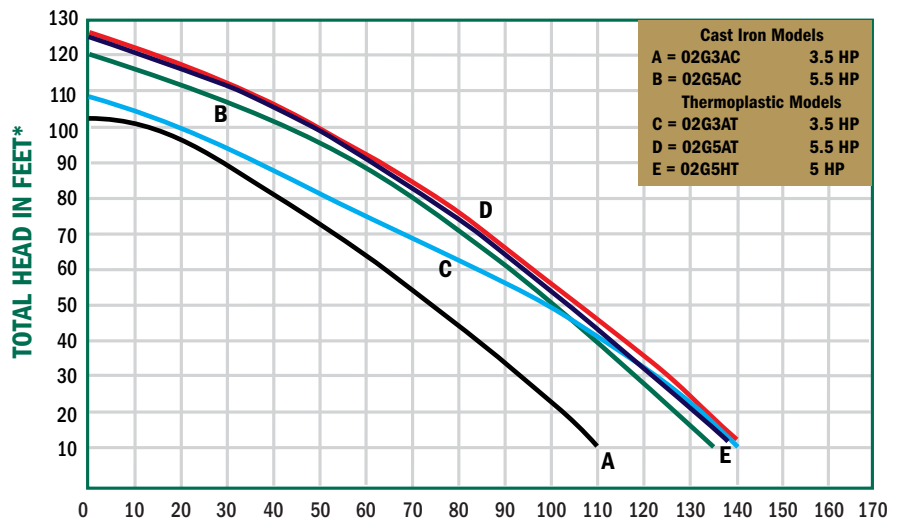

CAPACITY IN US GALLONS PER MINUTE @ 3600 RPM
*CONVERT TO PSI, DIVIDE BY 2.31 | LIQUID WATER SPECIFIC GRAVITY 1.0

Cast Iron | Thermoplastic

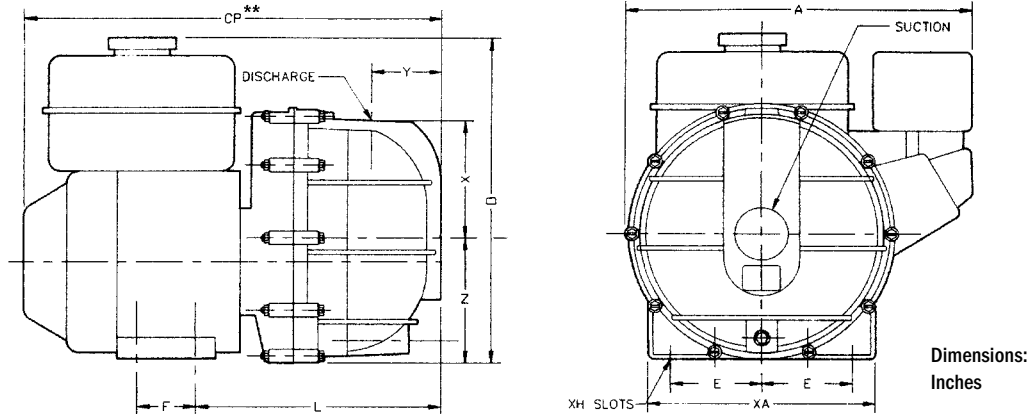

Dimensions

Model No.	HP†	A	XA	CP**	E	XH	O	X	Y	Z	Suct	Disch.
02G3AT	3.5	16.5	7.3	17.8	3.6	.44 X .64	13.2	4.8	2.8	5.5	2"	2"
02G5AT	5.5	16.5	7.3	17.8	3.6	.44 X .64	13.2	4.8	2.8	5.5	2"	2"
02G5HT	5	16.5	7.3	17.8	3.6	.44 X .64	13.2	4.8	2.8	5.5	2"	2"
02G3AC	3.5	17.4	8.4	17.6	4.2	.40 X .40	16.1	6.8	4.4	4.9	2"	2"
02G5AC	5.5	17.4	8.4	17.6	4.2	.40 X .40	16.1	6.8	4.4	4.9	2"	2"

(*) Standard NPT (female) pipe thread. (***) This dimension may vary due to engine manufacturer's specifications.
 † HP class represents market category and is not intended to define actual horsepower.
 NOTE: Dimensions have a tolerance of $\pm 1/8"$.

2" Dewatering Pumps | Cast Iron

Model #	Ship WT. (lbs.)	Driver Type & HP	Shaft Seal	Tank Size (Qts.)	Run Time
02G3AC	65	B&S 525, 3.5 HP	Buna	3	180 min.
02G5AC	76	B&S CP650, 5.5 HP	Buna	3	90 min.

Features

- Cast iron construction, & impeller
- Solids Handling - 3/8" diameter
- Stainless steel shaft sleeve
- Steel base on cast iron models
- Maximum temperature 180°F
- Dual volute design
- Fiber Gasket Casing Seal
- Delivers up to 52 PSI and maximum 140 GPM
- Optional Viton® or silicon carbide mechanical seals

2" Dewatering Pumps | Thermoplastic

Model #	Ship WT. (lbs.)	Driver Type & HP	Shaft Seal	Tank Size (Qts.)	Run Time
02G3AT	38	B&S 525, 3.5 HP	Buna	3	180 min.
02G5AT	43	B&S CP550, 5.5 HP	Buna	3	90 min.
02G5HT	45	Honda GC160, 5 HP	Buna	1.8	60 min.

Features

- Thermoplastic construction
- Polypropylene impeller
- Solids Handling - 7/16" diameter
- O-ring casing seal
- Replaceable volute
- Maximum temperature 130°F
- Delivers up to 54 PSI and maximum 140 GPM
- Optional EPDM mechanical seals available

WARNING: Do not use in explosive atmosphere or for pumping volatile flammable liquids.

Cast Aluminum | High Pressure

A.Y. McDonald cast aluminum self-priming portable engine driven pumps can provide for home fire protection with optional hose kit. These pumps are capable of developing 75 lbs. of pressure at 30 GPM. Available with a choice of standard and heavy-duty engines for gasoline and diesel fuel engines.

Unit is standard with die-cast aluminum housing, cast iron impeller, and built-in check valve. All models standard with EPDM elastomers & seals. A.Y. McDonald engine driven dewatering pumps are reliable, cost effective and low maintenance.

Applications

Use for fire protection or irrigation. For use with non-flammable liquids which are compatible with pump component materials.

Features

- Available with Briggs & Stratton, Honda gasoline, or Hatz diesel Engines.
- 2" suction and discharge port sizes
- Discharge port rotates in 90° Increments
- Maximum flow/head: 130 GPM/108 PSI
- Maximum lift up to 26'
- One tool serviceability
- Suction strainer included
- Optional high pressure hose kit
- Optional wheel kit



Model 02P5XHR



02S5HK
2" High Pressure Hose Kit

High Pressure Pump Performance Curve

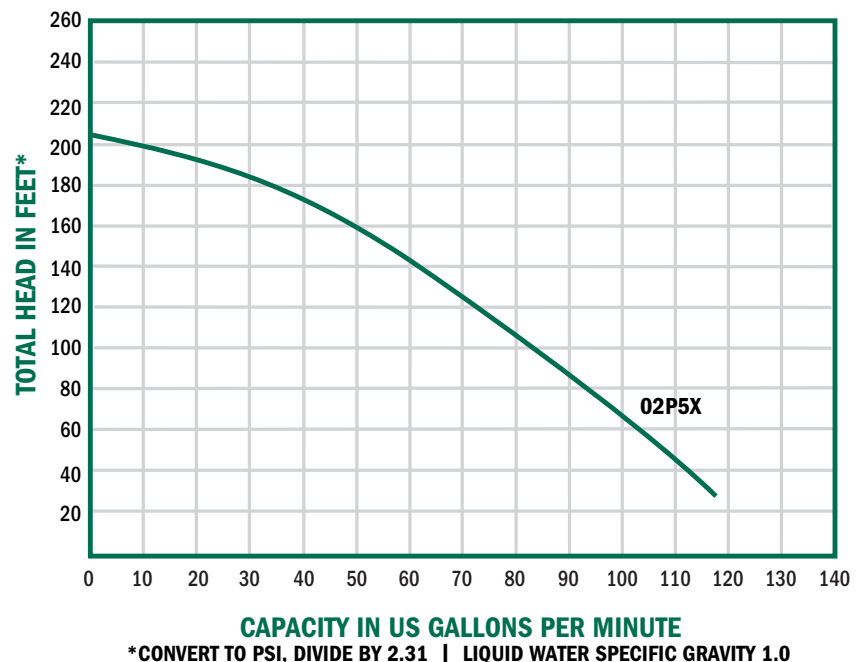

Cast Aluminum | High Pressure

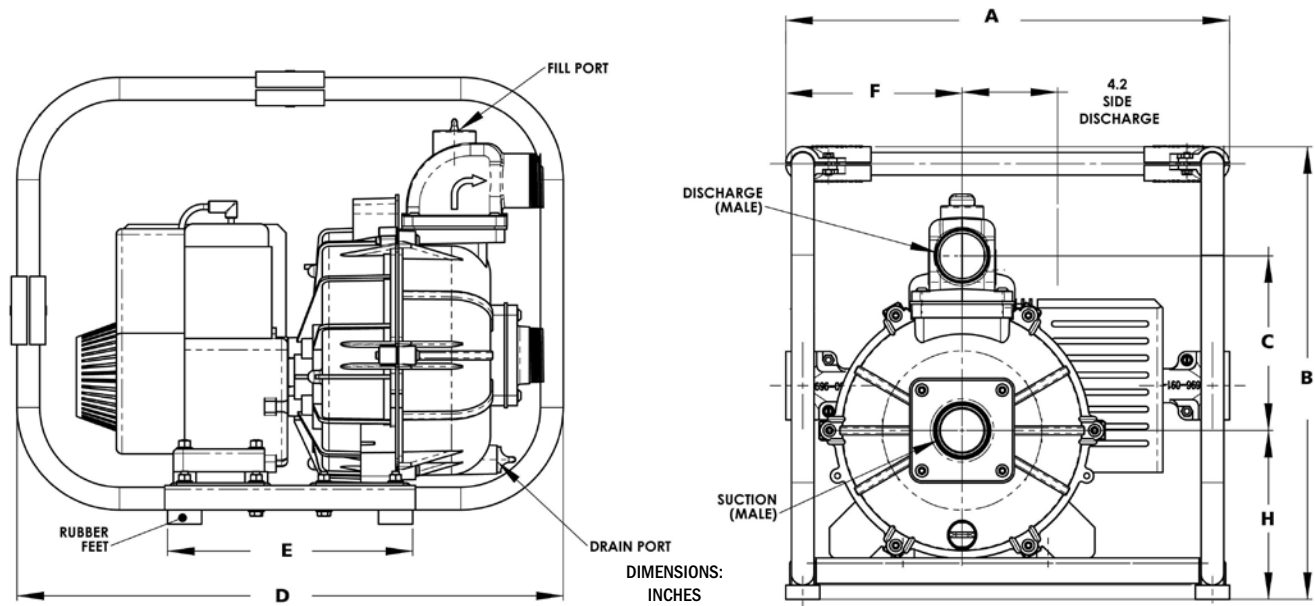

Dimensions

Model	A	B	C	D	E	F	Suct*	Disch*
02P5X	19.50	19.90	7.7	24	10.8	7.5	*2.00	*2.00

(*) Standard NPT (male) pipe thread.

Gas Engine Driven Pumps

Model - Gas	"H"
02P5XR	7.4

Diesel Engine Driven Pumps

Model - Diesel	"H"
02P5XZR	7.9

2" High Pressure Pumps

Model #	Ship Wt. (lbs.)	Driver Type & HP	Shaft Seal	Tank Size (Qts.)	Run Time	Mounting
02P5XAR	90	B&S CP650 6.5 HP Pro	EPDM/CAR/CER	3	120 Min.	Roll Cage
02P5XHR	86	Honda GX160, 5.5 HP	EPDM/CAR/CER	3.88	100 Min.	Roll Cage
02P5XZR	107	Hatz 4.8 HP	EPDM/CAR/CER	2.6	110 Min.	Roll Cage

WARNING: Do not use in explosive atmosphere or for pumping volatile flammable liquids.

Optional Viton® seals and elastomers include o-rings and check valve. Hose Kit with 100' of high pressure discharge hose, 15' of suction hose, fire nozzle, hose wrench, adapter, & weight is 38 lbs. Two wheel truck assemblies with semi-pneumatic tires for pumps with roll cages are available.

*Viton® and Teflon® are registered trademarks of DuPont.

2" & 3" Engine Driven | Trash Pump

A.Y. McDonald high-volume self-priming centrifugal trash pumps come standard with a ductile iron impeller to resist abrasion and one tool serviceability for cleanout. All pumps feature aluminum housing, cast iron wear parts, built-in check valve, suction strainer and heavy duty steel frame. Standard flanges with male NPT threads. A.Y. McDonald engine driven trash pumps are reliable, cost effective, and low maintenance.

Applications

Dewatering and trash applications with solids handling capability. For use with non-flammable liquids which are compatible with pump component materials.

Features

- Cast aluminum with cast iron wear parts
- Available with Briggs & Straton, Honda gasoline or Hatz diesel engines
- Removable suction and discharge port sizes 2" and 3"
- Discharge port rotates 90° increments
- Maximum flow: 200 to 300 GPM
- Maximum head: 105' to 115'
- Maximum lift up to 26'
- Solids handling up to 1 1/4" diameter
- Silicon-carbide seal with dry run survivability / Viton® mechanical seal
- Easy clean out with one tool serviceability
- Optional Viton® elastomers
- Optional wheel kit
- Maximum temperature 180°F



Model 03S5XHR

Trash Pump Performance Curves

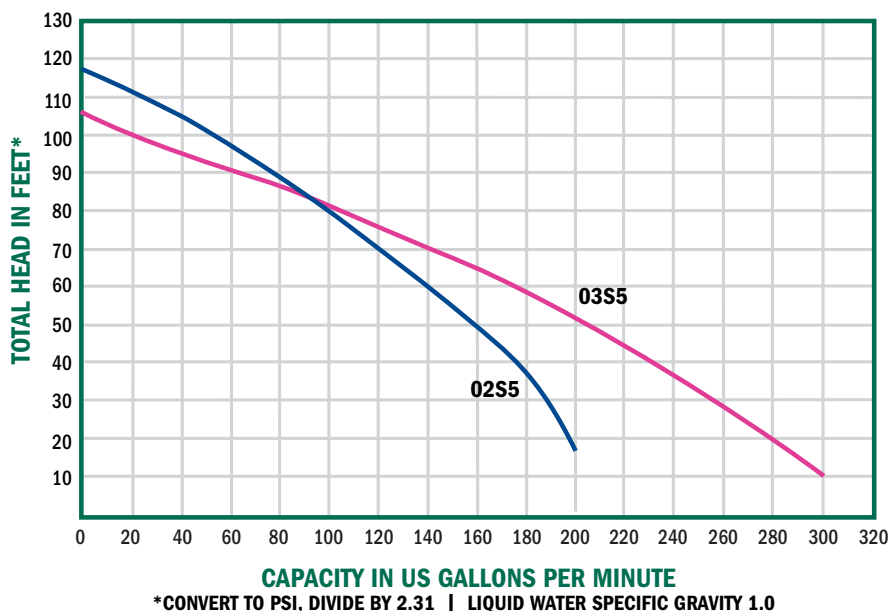

2" & 3" Engine Driven | Trash Pump

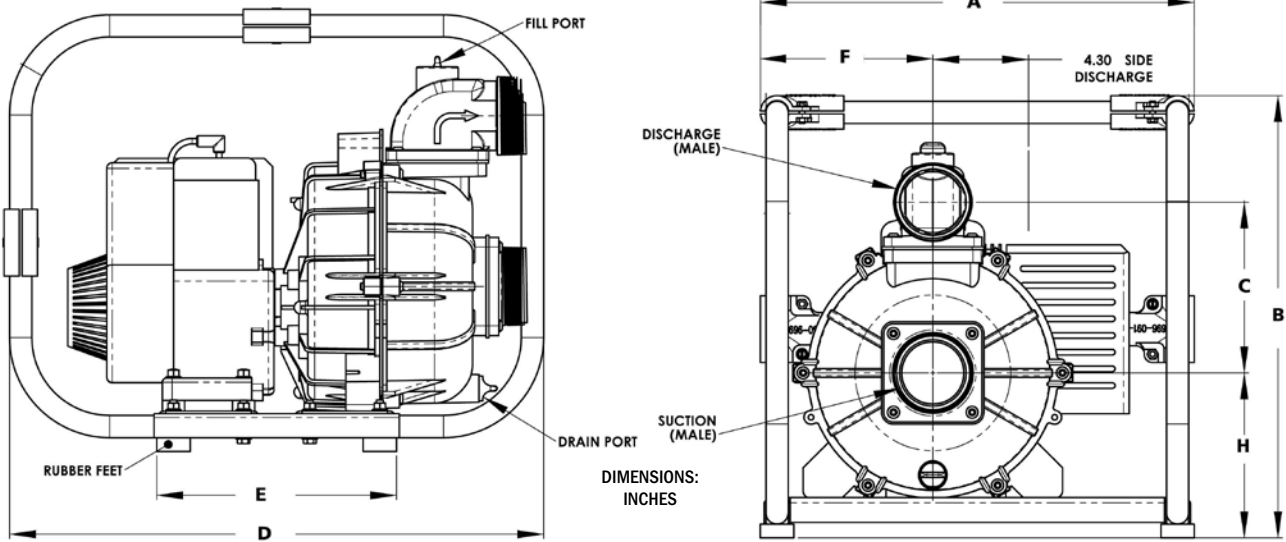

Dimensions

Model	A	B	C	D	E	F	Disch*	Suct*
02S5X	19.50	19.9	7.7	24	10.8	7.5	2.00	2.00
03S5X	19.50	19.9	7.7	24	10.8	7.5	3.00	3.00

(*) Standard NPT (male) pipe thread.

Gas Engine Driven Pumps

Model - Gas	"H"
02S5XR	7.4

Diesel Engine Driven Pumps

Model - Diesel	"H"
02S5XZR	7.9

2" Trash Pump

Model #	Ship WT. (lbs.)	Driver Type & HP	Shaft Seal	Tank Size (Qts.)	Run Time	Mounting
02S5XAR	87	B&S CP650 6.5 HP	Viton®*/Sic/Sic**	3	100 min.	Roll Cage
02S5XHR	91	Honda GX160 5.5 HP	Viton®*/Sic/Sic**	3.8	100 min.	Roll Cage
02S5XZR	112	Hatz Diesel 4.8 HP	Viton®*/Sic/Sic**	2.6	110 min.	Roll Cage

Solids Handling - 1" diameter

3" Trash Pump

Model #	Ship WT. (lbs.)	Driver Type & HP	Shaft Seal	Tank Size (Qts.)	Run Time	Mounting
03S5XAR	96	B&S CP650 6.5 HP	Viton®*/Sic/Sic**	3	100 min.	Roll Cage
03S5XHR	100	Honda GX160 5.5 HP	Viton®*/Sic/Sic**	3.8	100 min.	Roll Cage
03S5XZR	121	Hatz Diesel 4.8 HP	Viton®*/Sic/Sic**	2.6	110 min.	Roll Cage

Solids Handling - 1 1/4" diameter

WARNING: Do not use in explosive atmosphere or for pumping volatile flammable liquids.

*Viton® is a registered trademarks of DuPont.

**SIC = Silicon Carbide

3" & 4" Engine Driven | Trash Pump

The A.Y. McDonald line of engine driven trash pumps are constructed of heavy duty sand cast components featuring removable/replaceable cast iron volutes, impellers, and wearplates. Simple cleanout design permits easy removal of trash and debris without disconnecting hoses.

Pumps are available with side valve or overhead valve engines from various engine manufacturers. An electric start option is available on 4" model. A.Y. McDonald engine driven trash pumps are reliable, cost effective, and low maintenance.

Applications

Designed for applications which require high flow efficiency and solids handling capability. For use with non-flammable liquids which are compatible with pump component materials.

Features

- Cast aluminum with cast iron wearparts construction
- Viton®/silicon carbide mechanical seal & Buna-N o-ring
- 3" & 4" NPT port sizes
- Self-priming up to 20'
- Engine options: Briggs & Stratton, or Honda
- Available in 8, 9 and 13 HP engines
- Pumps include heavy duty base or roll frame
- Suction strainer included
- Solids handling up to 2" diameter



3" Trash Pump



04S13HPV
4" Trash Pump

Trash Pump Performance Curves

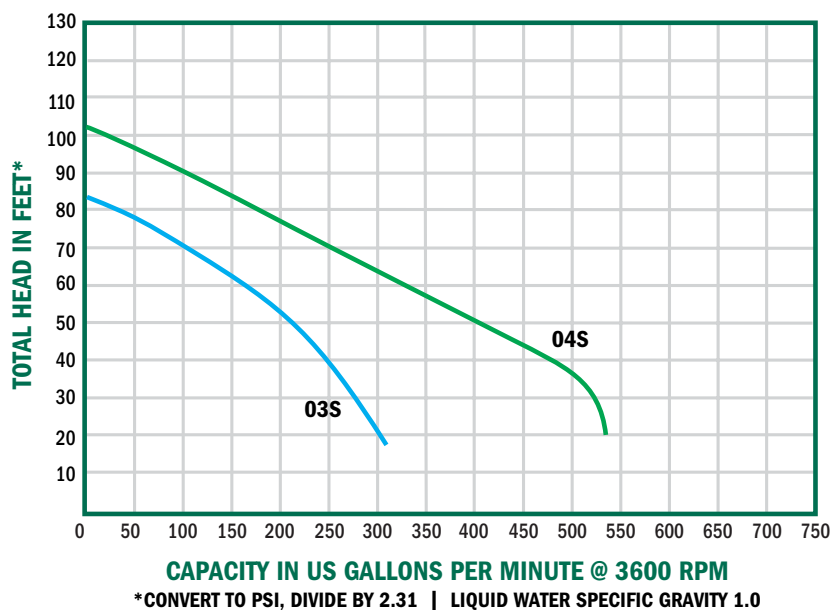

3" & 4" Engine Driven | Trash Pump

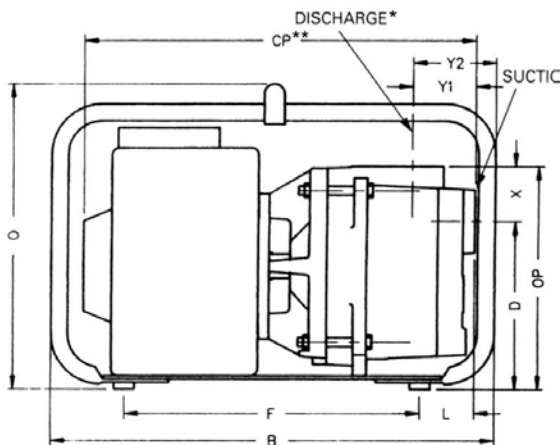

3" Models

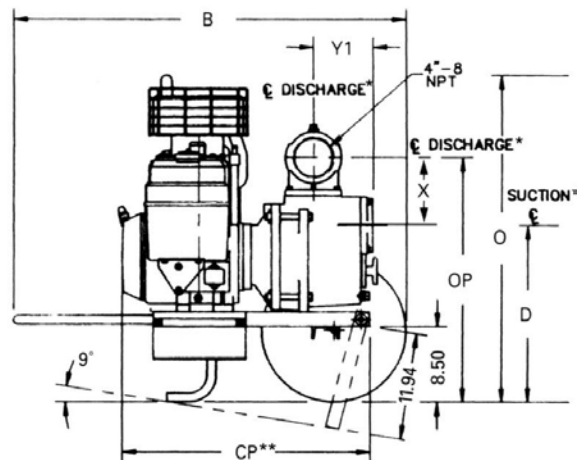

4" Models

Dimensions

Model#	Width	B	CP**	D	F	L	O	OP	X	Y1	Y2	Suct.	Disch.
03S8IR	21.3	27.3	25.5	11.0	13.3	6.0	23.8	14.5	3.5	5.0	6.0	3"	3"
03S9HR	21.3	27.3	25.5	11.0	13.3	6.0	23.8	14.5	3.5	5.0	6.0	3"	3"
04S13HPV	37.5	44.5	27.4	19.6	N/A	N/A	36.6	27.5	7.8	6.5	N/A	4"	4"

(*) Standard NPT (female) pipe thread.

(**) This dimension may vary due to engine manufacturer's specifications.

NOTE: Dimensions have a tolerance of $\pm 1/8"$.

3" Engine Driven Trash Pumps

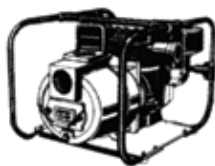

Model #	Driver	Shaft Seal	Ship WT.	Run Time	Tank Size
03S8IR	8 HP Briggs & Stratton 1350*	Viton/Sic/Sic**	143 lbs.	90 min.	4.0 qt.
03S9HR	9 HP Honda GX270*	Viton/Sic/Sic**	158 lbs.	100 min.	6.4 qt.

Solids Handling - 1 1/2" diameter

4" Premium Engine Driven Trash Pumps



Model #	Driver	Shaft Seal	Ship WT.	Run Time	Tank Size
04S13HPV	13 HP Honda GX390*†	Viton/Sic/Sic**	299 lbs.	80 min.	6.9 qt.

Solids Handling - 2" diameter

*Oil alert included

**SIC = Silicon Carbide

†12V DC electric start (battery not included)

WARNING: Do not use in explosive atmosphere or for pumping volatile flammable liquids.

3" & 4" Engine | Trash Pump

The A.Y. McDonald engine driven trash pumps are constructed of heavy duty sand cast aluminum components featuring replaceable ductile iron impellers and steel wearplates. Simple front cleanout design permits easy removal of trash and debris without disconnecting hoses.

Pumps are available with Honda gasoline engine. All are furnished with heavy-duty steel roll cages, suction strainers, and 90° degree discharge elbows.

Applications

Designed for applications which require high flow efficiency and solid handling capability. For use with non-flammable liquids which are compatible with pump component materials.

Features

- Cast aluminum construction
- Pump includes heavy duty steel roll cage
- 3" & 4" NPT port sizes
- Self-priming to 25'
- Engine options: Honda gasoline
- Available in 8 HP and 13 HP (includes heavy duty steel roll cages) engines
- Solids handling to 1 1/2" & 2 5/8" diameter
- Viton®/silicon carbide mechanical seals



Model 03S8HR
3" trash pump



Model 04S13HR
4" trash pump

Composite Performance Curves

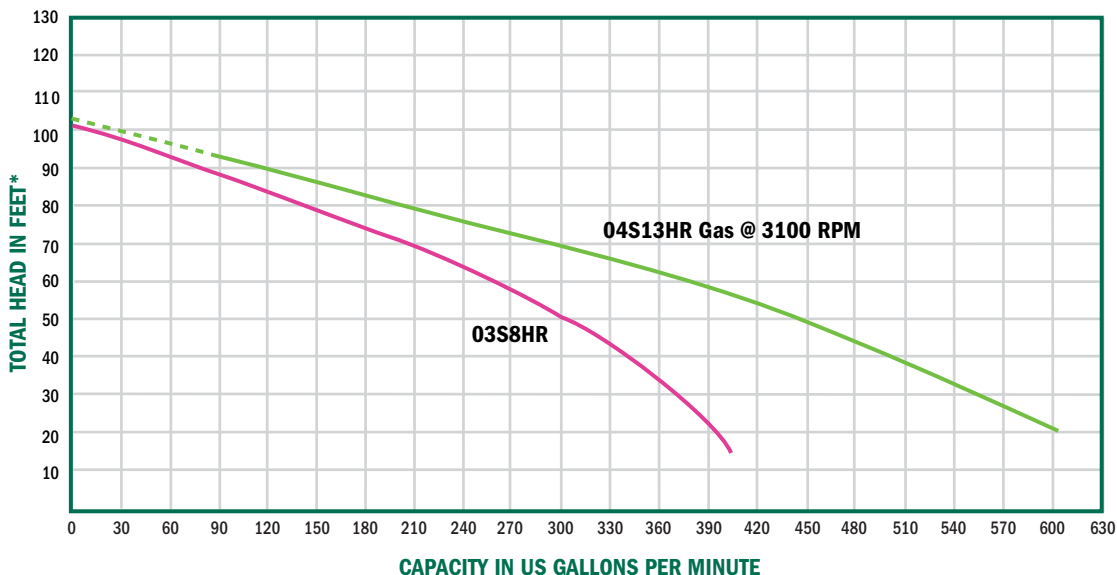

*CONVERT TO PSI, DIVIDE BY 2.31 | LIQUID WATER SPECIFIC GRAVITY 1.0

3" & 4" Engine | Trash Pump

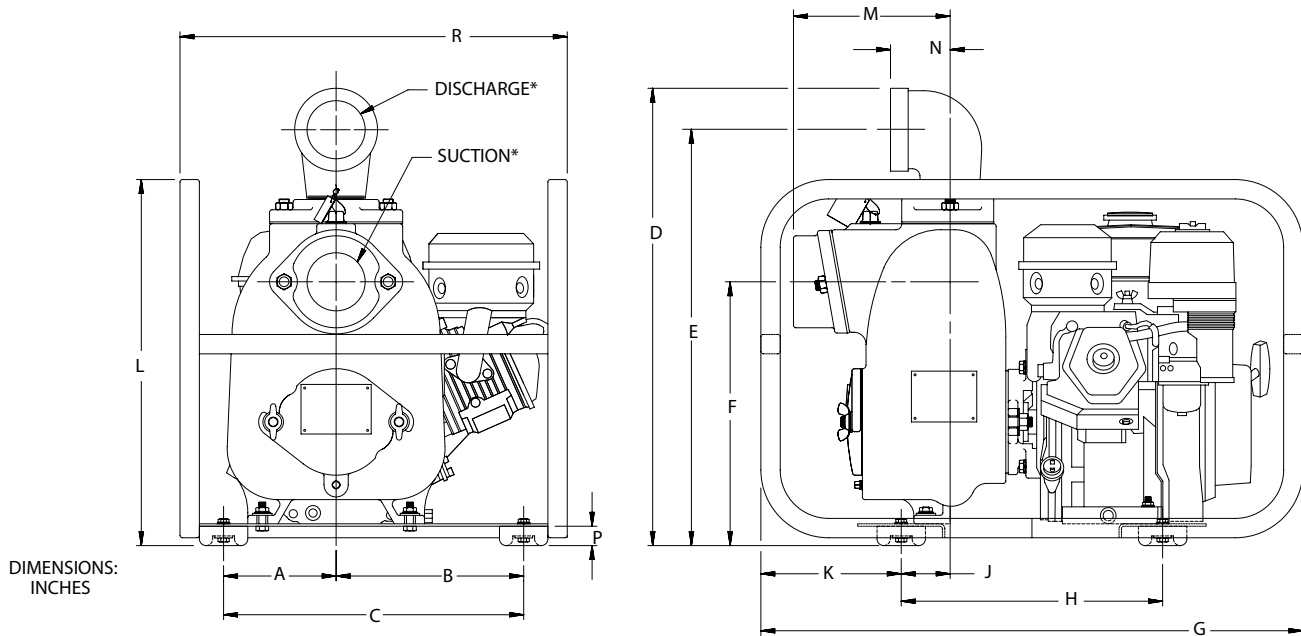

Dimensions

Model	A	B	C	D	E	F	G	H	J	K	L	M	N	P	R	Suct*	Disch*
03S8HR	5.81	9.69	15.50	23.62	21.50	13.62	28.00	13.50	3.06	7.25	18.90	8.06	3.08	1.00	20.00	3.00	3.00

(*) Standard NPT pipe thread.

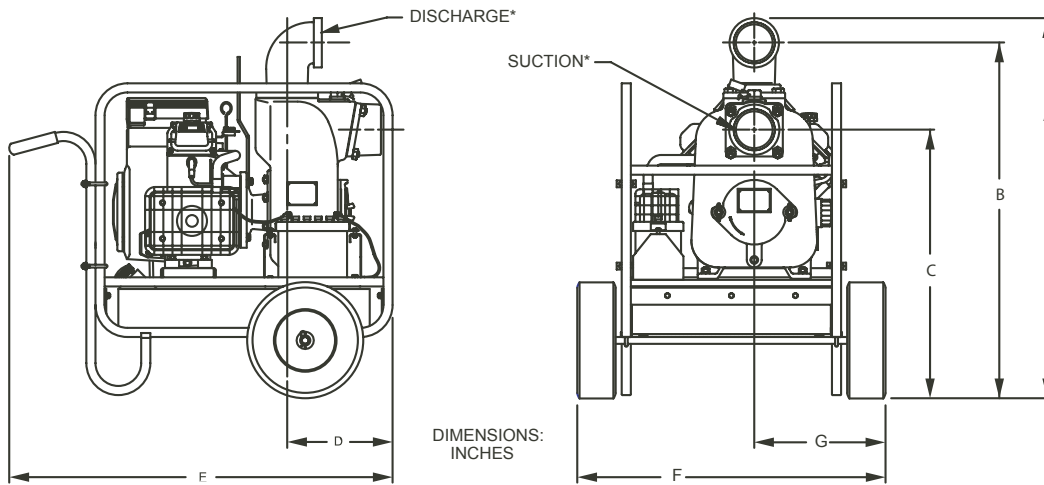

Model	A	B	C	D	E	F	G	Suct*	Disch*
04S13HR	29.66	26.96	17.44	12.50	36.50	22.50	13.76	4.00	4.00

(*) Standard NPT pipe threads.

Note:
04S13HR shown with optional wheel kit

3" & 4" Trash Pump

Model No.	Ship Wt (lbs.)	Driver Type & HP	Port size Suc x dis (NPT)	Basic Construction	Shaft Seal	Tank Size (Qts.)	Run Time	Mounting
03S8HR	136	Honda 8	3" x 3"	Aluminum	Viton®*/Sic/Sic**	1.6 gal.	2.7 hrs.	Roll cage
04S13HR	262	Honda 13	4" x 4"	Aluminum	Viton®*/Sic**	6.9 gal.	1.2 hrs	Roll cage

*Viton® is a registered trademarks of DuPont. **SIC = Silicon Carbide

WARNING: Do not use in explosive atmosphere or for pumping volatile flammable liquids.

6" Engine | Trash Pump

The A.Y. McDonald engine driven trash pumps are constructed of heavy duty sand cast aluminum with cast iron and stainless steel internal parts for wear resistance, and durability. Built-in slide mechanism features nylon and powder coated steel components that permit servicing, repairing, and cleaning entire pump without removing hoses or pump components from trailer.

Pumps are available with gasoline or diesel engine options; as well as trailer or skid mounted options.

Applications

Designed to handle applications which require high flow efficiency and solid handling capability. For use with non-flammable liquids which are compatible with pump component materials.

Features

- Cast aluminum casing and adapter
- Cast iron seal plate, volute, & manifold
- Stainless steel impeller
- Silicon carbide mechanical seal and Buna-N o-rings & check valve
- 6" NPT port size
- Self priming to 20'
- Solids handling to 3" diameter
- Includes seal wash feature for extended seal life
- 12 volt electric star
- Digital tachometer/hourmeter included
- Maximum temperature 180°F
- D.O.T. Approved Trailer - refer to your state and local codes for registration



Composite Performance Curves

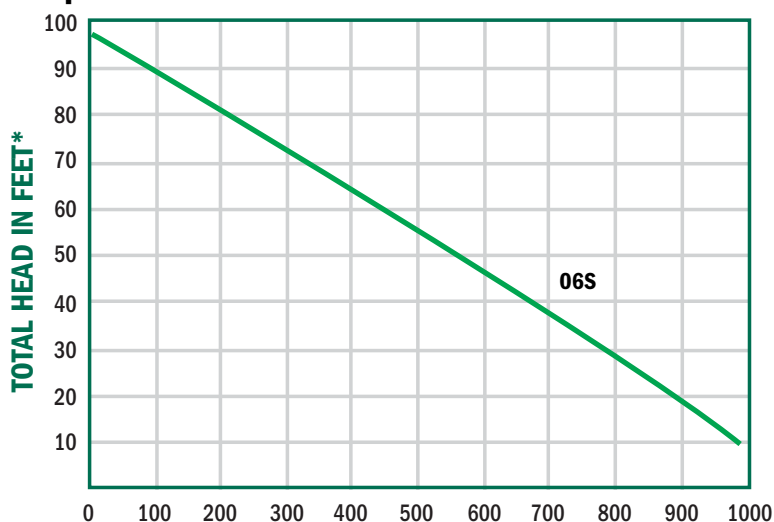

CAPACITY IN US GALLONS PER MINUTE @ 3600 RPM

*CONVERT TO PSI, DIVIDE BY 2.31 | LIQUID WATER SPECIFIC GRAVITY 1.0

6" Engine | Trash Pump

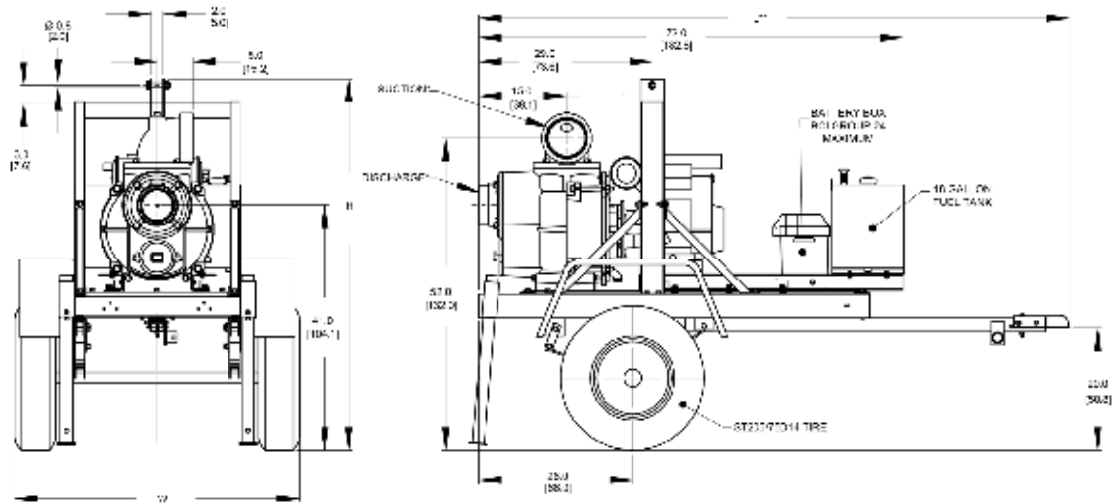
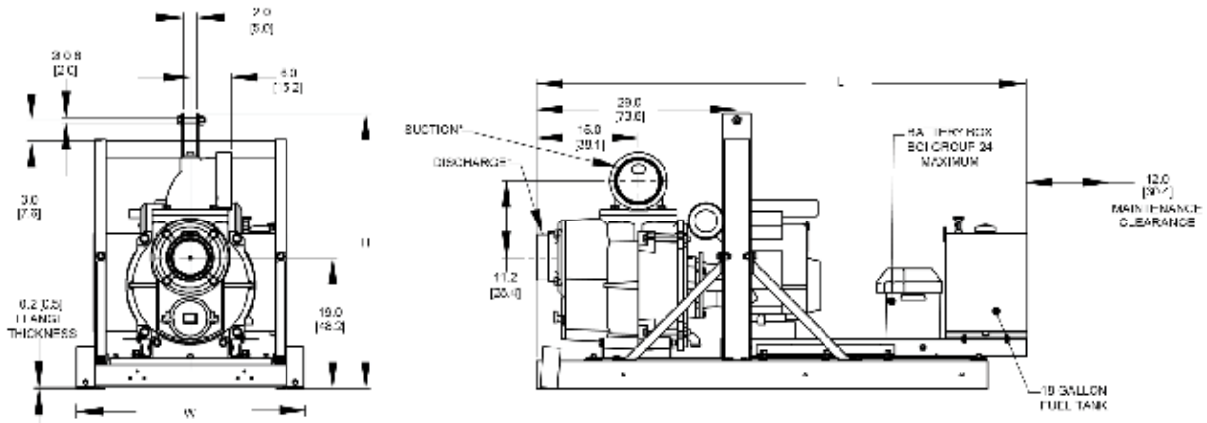

Dimensions

Model	L	W	H	Suct*	Disch*
06S24HTV	99.0	48.0	62.0	6	6
06S24HSV	71.0	33.0	40.0	6	6
06S27ITV	99.0	48.0	62.0	6	6
06S24YSV	71.0	33.0	40.0	6	6
06S24YTV	99.0	48.0	62.0	6	6

(*) Standard NPT pipe thread.

NOTE: Dimensions are in inches and have a tolerance of $\pm 1/8'$

6" Trash Pumps

Model No.	Description/ Type of Pump	Ship Wt (lbs.)	Tank Size	Run Time	Maximum Solids Dia.	Base	Engine Type
06S24HTV	Honda OHV +++▲	1000 lbs.	20 gal.	9 hrs.	3"	Trailer	2 cycle air cooled
06S24HSV	Honda OHV +++▲	725 lbs.	20 gal.	9 hrs.	3"	Skid	2 cycle air cooled
06S27ITV	B&S Vanguard V-Twin OHV+++▲	1075 lbs.	20 gal.	9 hrs.	3"	Trailer	2 cycle air cooled
06S24YSV	Yanmar 3TNM72 Diesel+++▲	975 lbs	20 gal.	9 hrs.	3"	Skid	3 cycle liquid cooled
06S24YTV	Yanmar 3TNM72 Diesel+++▲	1250 lbs	20 gal.	12 hrs.	3"	Trailer	3 cycle liquid cooled

Solids Handling - 3" diameter

+++ Electric start, Battery not included - requires 12 Volt DC; BCI Group 24, Min 500 CCA battery

▲ Oil alert included

WARNING: Do not use in explosive atmosphere or for pumping volatile flammable liquids.

2" Engine Driven | Dredging Pump

A.Y. McDonald engine driven dredging pump is designed for pumping sea water and fresh water containing up to 25% sand, debris, and other abrasive particles.

This pump is constructed of wear resistant high chromium stainless steel internal components that are designed to last for over 500 hours of service with regular maintenance of rinsing pump after each use. The high chromium stainless steel components are investment cast and CNC machined for maximum efficiency, performance and quality. Dual volute design reduces radial load on engine. The pump is coupled to a 5 1/2 HP Honda engine that is also known for reliability and easy starting. The four bolt casing design and removable type volute offer simple maintenance and fast cleanout of the pump. A.Y. McDonald Dredging pumps are reliable, cost effective, and low maintenance.

Applications

Besides pumping seawater, this unit can be used for other marine applications including dredging, pile driving, pier maintenance, emergency bilging, and wash down. For use with non-flammable liquids compatible with pump component materials.

Features

- High chromium stainless steel internal components resist wear from sea water mixed with abrasive sand
- Silicon carbide mechanical seal resists abrasives and extends seal life
- Heavy duty cast iron casing and adapter ensures durability for severe service conditions
- Dual volute design
- O-ring casing seal for ease of service & cleaning
- Maximum working pressure 75 PSI
- Maximum temperature 160°F
- Maximum flow 173 GPM
- Discharge pressure up to 44 PSI
- Solids handling up to 1/2" diameter
- Self-primes to 10' in 1 minute
- Maximum suction lift 20'
- 5 1/2 HP Honda OHV engine with oil alert



Model 02J5HCR

2" Dredging Pump Performance Curve

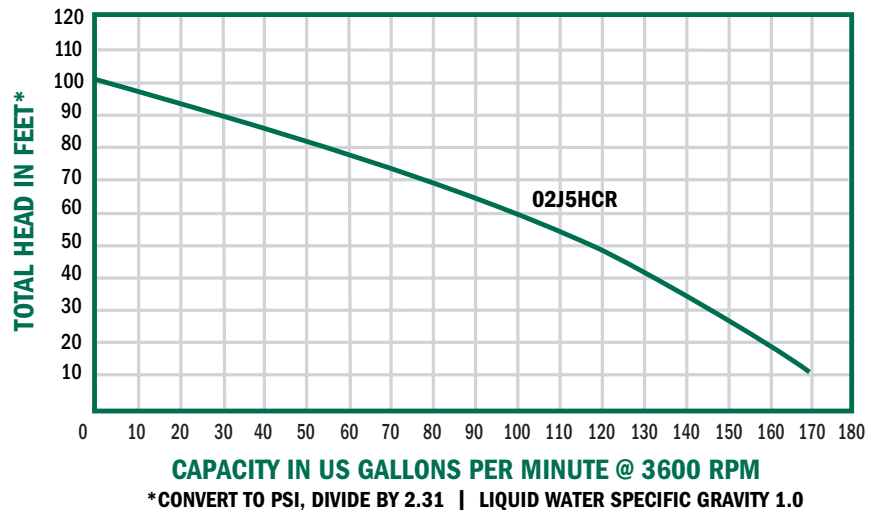

2" Engine Driven | Dredging Pump

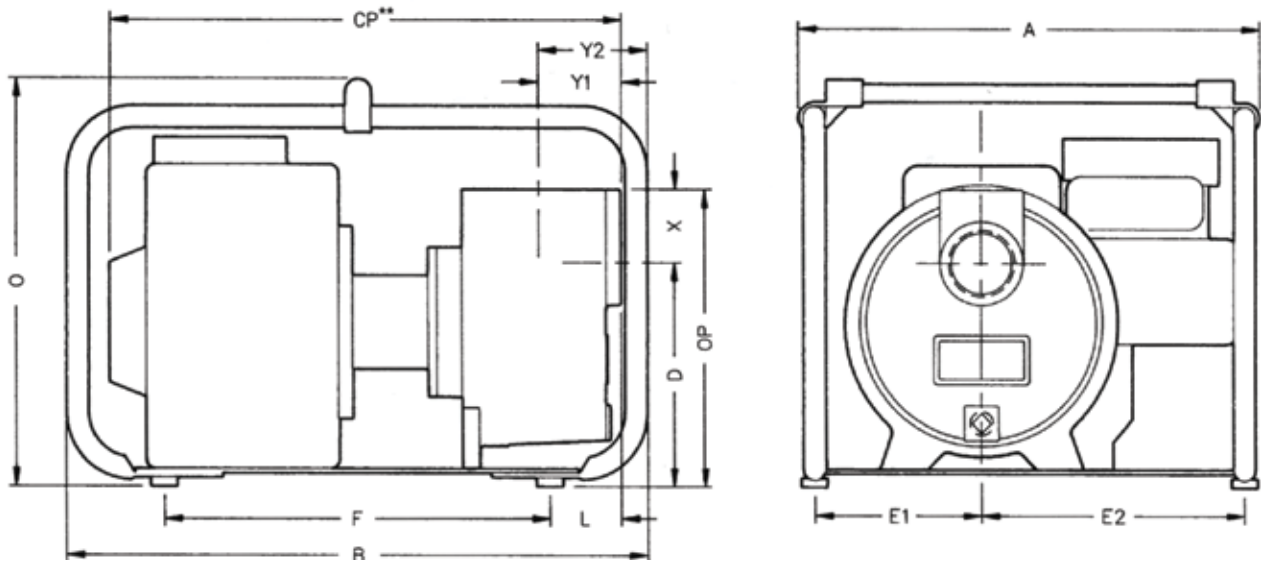

Dimensions

Model No.	HP	A	B	CP**	D	E1	E2	F	L	O	OP	X	Y1	Y2	Suct.	Disch.
02J5HCR	5 1/2	19.5	24.3	19.0	6.8	7.0	11.0	9.3	6.0	20	9.5	2.6	3.1	4.6	2"	2"

(*) This dimension may vary due to engine manufacturer's specifications.

NOTE: Dimensions have a tolerance of $\pm 1/8"$.

2" Dredging Pumps

Model No.	Port Size	Driver	Construction	Shaft Seal	Run Time	Tank Size	Max Solids	Ship Wt.
02J5HCR	2" NPT	5.5 HP Honda GX160 OHV with oil alert	Cast iron w/ high Chromium stainless Steel wear Parts	Silicon carbide w/Buna-N	100 min.	3.8 qt.	1/2"	85 lbs.

Solids Handling - 1/2" diameter

*Viton® is a registered trademarks of DuPont. **SIC = Silicon Carbide

Self-Priming | Diaphragm

The A.Y. McDonald line of 3" Diaphragm pumps features two stage, forty-four/one gear reduction with a large diameter output gear and heavy duty ball bearing construction. Often referred to as mud pumps or sludge pumps.

A.Y. McDonald Diaphragm pumps are available with a choice of drivers to meet your application requirements: Briggs & Stratton or Honda gasoline engines, Hatz diesel or 115 VAC electric motor with weatherproof cord and switch. Built-in molded polyurethane flapper/check valve assures self-priming to 20 feet after initial prime. Heavy duty gear box is designed to operate pumps at 40 strokes per minute for electric motor and 60 strokes per minute for engine models. Each unit includes a 3" NPT steel suction strainer, two 3" NPT nipples, and a wheel kit with 10" semi-pneumatic transport wheels for portability. **Suction and discharge port size cannot be reduced.**

Applications

Designed to pump mud, slurry, sewage, and thick liquids that have the ability to flow. Pumps are designed for use with non-flammable liquids which are compatible with pump component materials.

Features

- Sand cast aluminum construction for portability and durability
- Thermoplastic rubber diaphragm
- 3" NPT suction and discharge
- 1 5/8" diameter solids handling capability
- Modular component design permits easy maintenance and cleanout
- Driver options: gasoline engine or electric motor
- Delivers up to 90 GPM
- Maximum temperature 180°F
- Suction strainer included
- Model 03D1.5V - 1.5 HP single phase, 115/230 Volt motor with manual reset overload includes 20 foot 115 VAC power cord and weatherproof on/off switch



Model 03D5A

Handle not shown



Diaphragm Pump Performance Curves

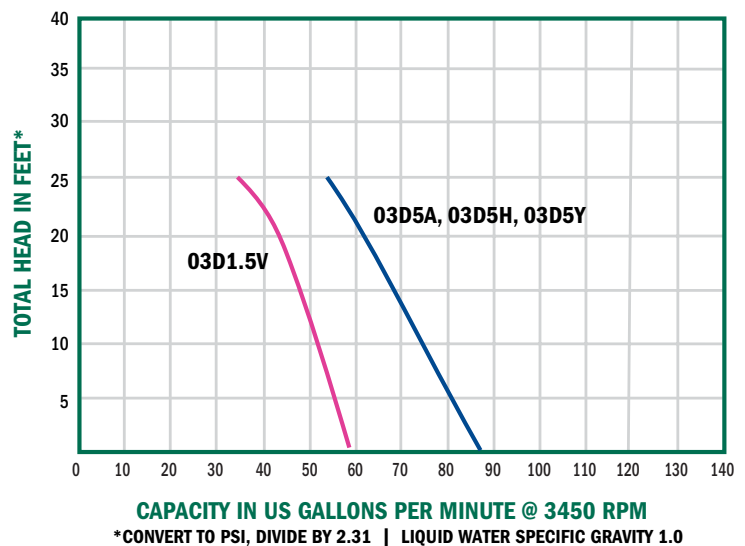

Self-Priming | Diaphragm

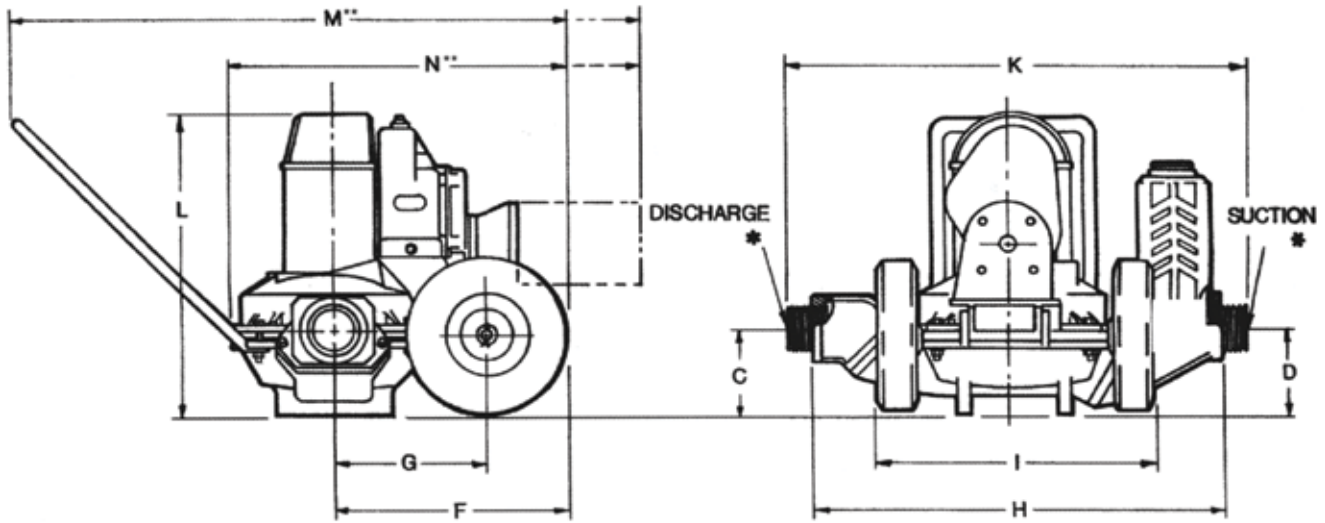

Dimensions

Model No.	Driver	SUC*	DIS*	C	D	F	G	H	I	K	L	M**	N**	Shpg. Wt.
03D1.5V	1.5 HP Electric motor	3"	3"	6.2	6.3	14.5	9.5	26.5	17.9	30.0	22.0	43.5	27.5	186 lbs.
03D5A	5.5 HP Briggs & Stratton CP550	3"	3'	6.2	6.3	14.5	9.5	26.5	17.9	30.0	22.0	41.5	25.5	181 lbs.
03D5H	5.5 HP Honda GX160	3"	3'	6.2	6.3	14.5	9.5	26.5	17.9	30.0	22.0	41.5	25.5	182 lbs.
03D5Z	4.8 HP Hatz diesel L20	3"	3'	6.2	6.3	14.5	9.5	26.5	17.9	30.0	22.0	43.0	27.0	203 lbs.

(*) Standard NPT (female) pipe thread.

(**) This dimension may vary due to motor or engine manufacturer's specifications.

NOTE: Dimensions have a tolerance of $\pm 1/8"$.

90° Rotatable Base on All Models



Fire Pump

The A.Y. McDonald Engine Driven line of High Pressure/Fire pumps deliver excellent pressure and flow for use in many applications including: fire protection, emergency fire fighting, washdown, and AG/Sprinkler. Portable units feature metal fuel tanks installed on engine or frame depending on model. 12 Volt DC electric start engine with recoil starter from Briggs & Stratton Vanguard, Honda Gasoline, or Yanmar Diesel engines are standard on these pumps.

Applications

For use with non-flammable liquids which are compatible with pump component materials.

Features

- Aluminum construction with replaceable hard coat anodized wear ring
- Viton® mechanical seals with silicon carbide & carbon faces
- 2 1/2" NPT Suction & Discharge ports
- Primes assist to 19'
- Maximum temperature 200°F
- Exhaust prime or hand prime depending on model
- Built-in discharge check valve
- Discharge pressure gauge included
- Suction strainer, nipples and heavy duty steel roll frame with battery tray included
- Maximum head up to 165 PSI/380' TDH
- Delivers to 270 GPM
- Optional NPT to Fire Hose thread available
- Optional wheel kit available



02.5FP13HR

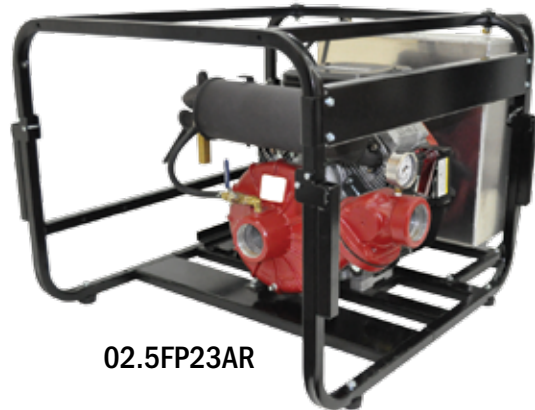

02.5FP23AR

Fire Pump Performance Curve

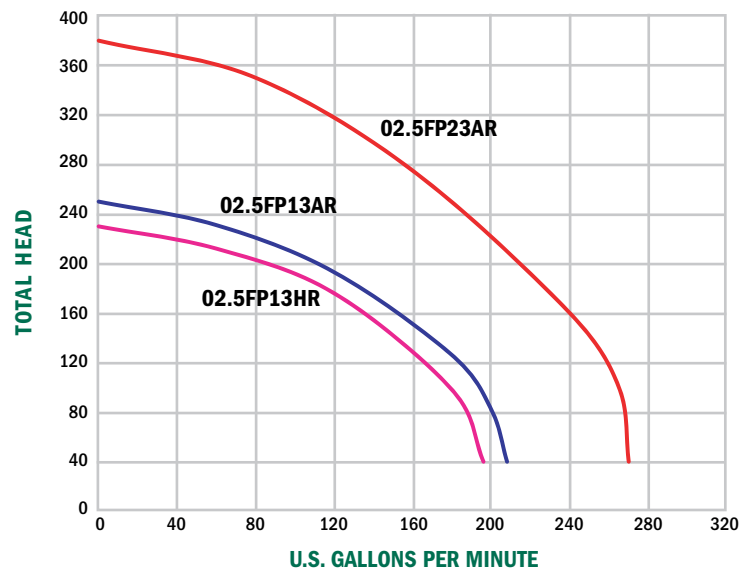

*CONVERT TO PSI, DIVIDE BY 2.31 | LIQUID WATER SPECIFIC GRAVITY 1.0

Fire Pump

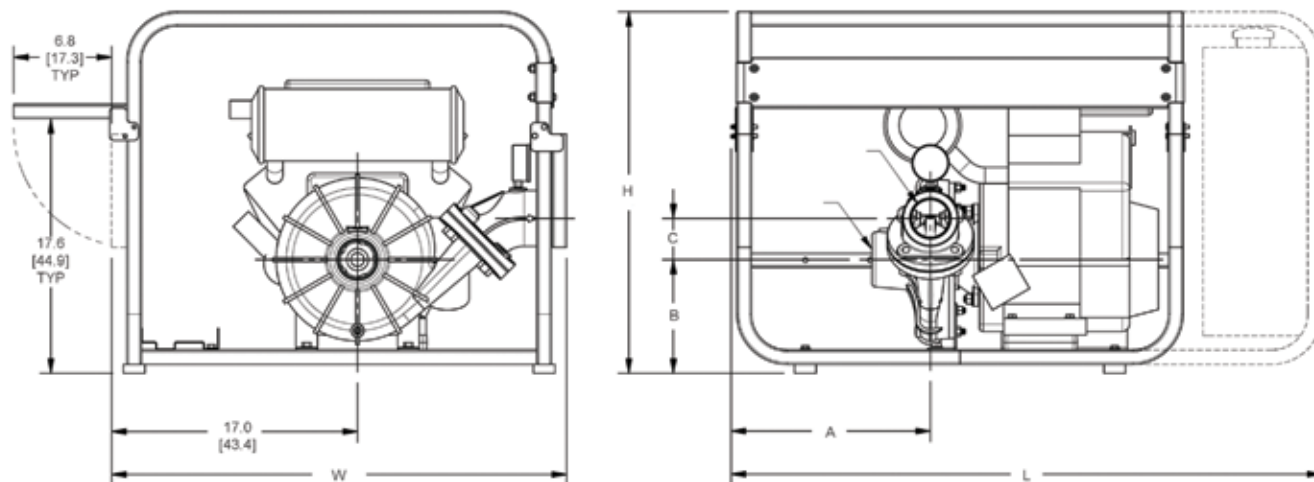

Dimensions

Model	HP Class*	A	B	C	L**	W	H	Suct*	Disch*
02.5FP13HR	13	13.3	6.8	4.6	31.8	31.6	25.1	2 1/2	2 1/2
02.5FP13AR	13	13.3	6.8	4.6	31.8	31.6	25.1	2 1/2	2 1/2
02.5FP23AR†	23	13.8	7.9	2.8	41.0	31.6	25.1	2 1/2	2 1/2

(*) HP Class represents market category and is not intended to define actual horsepower.

(*) Standard NPT (Male) pipe thread.

(**) This dimension may vary due to engine manufacturer's specifications.

NOTE: Dimensions are in inches (centimeters) and have a tolerance of $\pm 1/8"$.

(†) Minimal Assembly Required: Auxiliary Fuel Tank Shipped Uninstalled.

Pump Dimensional & Specification Data

Model No.	Curve	Driver	Seal Type & Elastomer/Faces	Prime Feature	Tank Size (Gal/Ltr)	Run Time (Hr.)	Ship Wt. (Lbs.)
02.5FP13HR	A	Honda GX390▲++	Viton® Silicon Carbide/Carbon	Hand	1.6/6.1	2.5	200
02.5FP13AR	B	B&S Vanguard 13 HP▲++	Viton® Silicon Carbide/Carbon	Exhaust	2.25/8.5	1.8	225
02.5FP23AR	C	B&S Vanguard 23 HP▲++	Viton® Silicon Carbide/Carbon	Exhaust	10/37.8	7.0	255

*Viton® is a registered trademarks of DuPont.

Construction: Aluminum

▲ Oil Alert Included

++ Electric Start



Quality made easy.

The A.Y. McDonald DuraMAC™ booster pump is built with quality components that make it last longer in the field. It includes a 2-gallon tank to help avoid water hammer, as well as dry run protection if incoming water is interrupted. Compact size and quiet operation are benefits your customers will appreciate.

Choose A.Y. McDonald for:

- Friendly, responsive, dedicated customer service specialists
- Products built exclusively for professional installation
- Application-specific solutions to meet your needs
- Comprehensive product warranty program

Visit aymcdonald.com to learn more about our quality product lines, dependable customer service, and more than 156 years of industry-leading expertise.

More than a brand. **We're a family.**





A.Y. McDonald Mfg. Co. is a leading manufacturer of Waterworks Brass, Plumbing Valves, Pumps and Water Systems, and High Pressure Gas Valves and Meter Bars. The Company has distinguished itself with a proud tradition of quality and reliability since its founding in 1856.

The mission of A.Y. McDonald Mfg. Co., in the words of our founder, is “to make good products and sell them honestly.” We, the stockholders and employees, accomplish this by extending the McDonald family culture through excellent customer service and by focusing on our customers’ needs.



WARNING: It is unlawful in CALIFORNIA & VERMONT (effective 1/1/2010); MARYLAND (effective 1/1/2012); LOUISIANA (effective 1/1/2013) and the UNITED STATES OF AMERICA (effective 1/4/2014) to use any product in the installation or repair of any public water system or any plumbing in a facility or system that provides water for human consumption if the wetted surface area of the product has a weighted average lead content greater than 0.25%. This prohibition does not extend to service saddles used in California, Louisiana or under USA Public Law 111-380.

