

# Operating Instructions

## Series FF9000 Spring Driven Hose Reels

Low Pressure Model Numbers:

FF9500 OLPBW

FF9600 OLPBW



### Dimensions

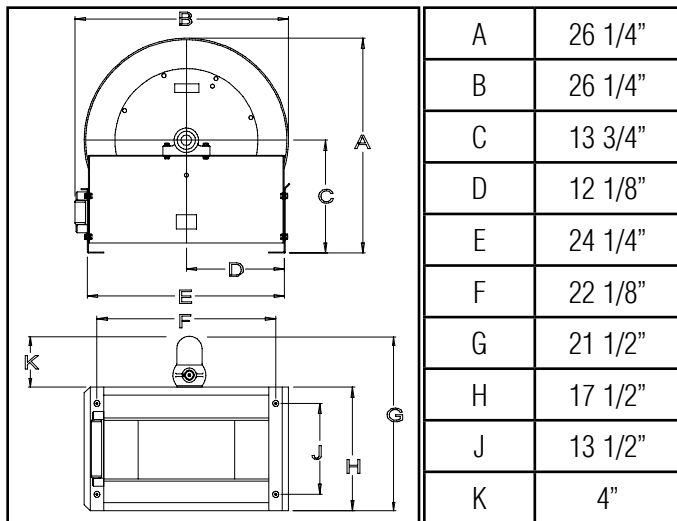

Four 7/16" diameter mounting holes

### SAFETY

1. Models designed for fuel are coded with the prefix "F" i.e., "FF9500 OLP." Check name plate on the reel before installing.
2. Do not use reel at higher pressures or temperatures than listed on the back of this bulletin.
3. Remove all spring tension before beginning disassembly process.
4. Reel spring motor case is permanently sealed. Any attempt to remove the spring motor may cause serious injury.

#### INSTALLATION:

The swivel union is packed separately in the reel carton, use teflon tape to assure a satisfactory seal. A flexible hose connection must be used between the hose reel inlet and the source of supply to prevent possible misalignment and binding. Non flexible connections will void the warranty, pressure rating of inlet hose must be equal to or more than the pressure rating of the reel. Consult factory for proper spring when installing reels above 16 ft.

#### LUBRICATION:

Hose reel spring and bearings are factory lubricated and require no further lubrication.

#### REPLACING HOSE:

1. Wind spool flange clockwise-facing swivel-until spring is tight.
2. Back off three turns and latch.
3. Insert hose through roller guide.
4. Connect hose fitting to female outlet ell.

#### ADJUSTMENTS:

To adjust spring tension, add or remove wraps of hose from the spool, one wrap at a time until desired tension is obtained.

#### REPAIRS:

Extensive repairs should be performed only by an authorized serviceman or factory to avoid damage which may void your warranty. Remove all spring tension before beginning disassembly process.

#### MODIFICATION:

Hose latching mechanism can be removed for constant tension applications.

Form# 1152-204 Rev: 7/2012

# Series FF9000 Spring Driven Hose Reels

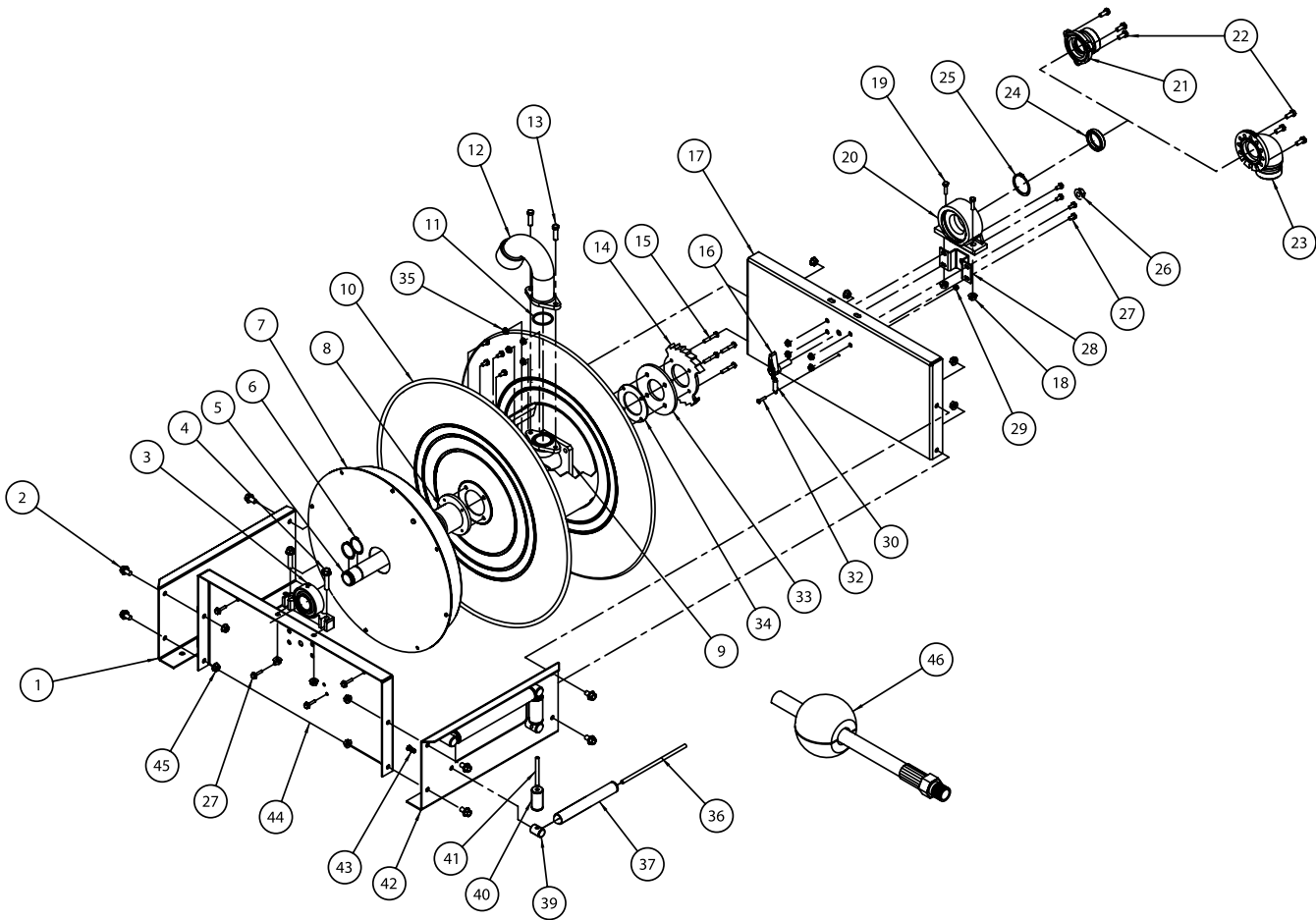

Item #	Part #	# Req	Description	Item #	Part #	# Req	Description	Item #	Part #	# Req	Description
1	261112	1	End frame	16	600454	1	Latch pawl assembly	30	260067	1	Latch spring
2	S44-2	8	3/8-16 x 5/8" screw	17	261703	1	Side frame	32	S393-2	1	10-32 shoulder screw
3	S600416	1	Pillow block	18	300107	2	5/16-18 hex nut	33	260586	1	Support washer
4	S44-8	4	3/8-16 x 1 3/4" screw	19	S2-55	2	5/16-18 x 1" screw	34	261116	1	Ratchet spacer
5	261114	1	Support shaft	20	600961	1	Bearing housing assembly	35	S281-4	12	1/4-20 hex nut
6	S140-34	2	Snap ring	21	261692	1	Straight inlet	36	261110	2	Guide roller pin
7	600545	1	Springcase assembly	22	S2-53	3	5/16-18 x 3/4" screw	37	262436-10.093	2	Guide roller - long
8	270888	1	Spring arbor	23	261700	1	90° Adapter	39	270014	4	Guide roller post
9	262270	1	Spindle 9000	24	600947-2	1	Ring seal	40	262436-2.968	2	Guide roller - short
10	600543	1	Sheave assembly	25	S140-45	1	Snap ring	41	270015	2	Guide roller pin
11	S211-224	1	O-ring	26	S280-8	1	1/2-20 hex nut	42	600542	1	Roller bracket assembly
13	S44-3	2	3/8-16 x 1" screw	27	S2-41	12	1/4-20 x 1/2" screw	43	S2-51	4	5/16-18 x 1/2" screw
14	261115	1	Latch ratchet	28	260934	1	Latch bracket	44	260895	1	Side frame
15	S2-47	4	1/4-20 x 1 1/2" screw	29	S82-15	1	10-32 nyloc nut	45	S281-6	10	3/8-16 hex nut

Item #	Description	# Req	FF9500 OLPBW	FF9600 OLPBW
12	Outlet shaft	1	261694-2	261694-3
46	Hose bumper assembly	1	600547-1	600547-2
--	Hose ID and length	--	1 1/4" x 50'	1 1/2" x 50'
--	Working pressure	--	600 PSI	600 PSI
--	Max. temperature	--	210° F	210° F