

Priming Assisted Centrifugal Pump



Model PA4A60D-4045T FT4

Size 4" x 4"



Total Head		Capacity of Pump in U.S. Gallons per Minute (GPM) at Continuous Performance				
P.S.I.	Feet					
61.6	142	200	200	200	200	200
52.0	120	408	545	675	750	750
43.4	100	428	580	730	854	990
34.7	80	432	589	740	867	1000
26.0	60	435	591	744	871	1010
17.3	40	437	592	746	876	1015
Suction Lift		25'	20'	15'	10'	5'

PUMP SPECIFICATIONS

Size: 4" x 4" (102 mm x 102 mm) Flanged.

Casing: Gray Iron 30.

Maximum Operating Pressure 104 psi (717 kPa).*

Semi-Open Type, Two Vane Impeller: Ductile Iron 65-45-12.

Handles 3" (76 mm) Diameter Spherical Solids.

Impeller Shaft: Stainless Steel 17-4 PH

Replaceable Wear Plate: Carbon Steel 1015.

Intermediate Bracket: Gray Iron 30.

Seal Plate: Gray Iron 30.

Seal: Cartridge Type, Mechanical, Oil-Lubricated, Double Floating, Self-Aligning. Silicon Carbide Rotating and Stationary Faces. Stainless Steel 316 Stationary Seat. Fluorocarbon Elastomers (DuPont Viton® or Equivalent). Stainless Steel 18-8 Cage and Spring. Maximum Temperature of Liquid Pumped 160°F (71°C).*

Shaft Sleeve: Alloy Steel 4130.

Priming Chamber: Gray Iron 30 Housing w/Stainless Steel Float and Linkage.

Discharge Check Valve: Ductile Iron Housing w/Buna-N Flapper.

Radial Bearing: Open Single Ball.

Thrust Bearing: Open Double Ball.

Bearing and Seal Cavity Lubrication: SAE 30 Non-Detergent Oil.

Gaskets: Resistant Synthetic Rubber, Cork, PTFE, Vegetable Fiber and Compressed Synthetic Fibers.

O-Rings: Buna-N, Fluorocarbon Elastomers (DuPont Viton® or Equivalent), PTFE.

Hardware: Standard Plated Steel.

Bearing and Seal Cavity Oil Level Sight Gauges.

*Consult Factory for Applications Exceeding Maximum Pressure and/or Temperature Indicated.

Standard Equipment: Hoisting Bail. Skid Base. Belt-Driven Diaphragm Primer. [Full Feature Control Panel](#), [Single Ball Type Float Switch](#).**

Optional Equipment: Battery. Skid Drag Base Kit Heated Priming Chamber Kit. Suction and Discharge Flange Kit (Quick Connect Coupling). High Speed (55 MPH/89 KM/H) Single Axle Pneumatic-Tired Wheel Kit^{w/o} DOT-Approved Lights and Electric Brakes. [Tandem Axle Over-the-Road Trailer](#) (Meets DOT Requirements) Available w/ Either Electric or Hydraulic Surge Brakes, Running Lights, Jack Stands and Safety Cables. Liquid Level Transducer.

**50 Ft. (15 m) Standard Length; Dual Switches and Alternate Cable Lengths Available From the Factory.



WARNING!

Do not use in explosive atmosphere or for pumping volatile flammable liquids.

ENGINE SPECIFICATIONS

Model: John Deere 4045T.

EPA Tier: Final Tier 4.

Type: Four Cylinder, Four Cycle, Turbocharged, Liquid Cooled Diesel Engine.

Displacement: 276 Cu. In. (4,5 liters).

Lubrication: Forced Circulation.

Air Cleaner: Dry Type.

Fuel Tank: 70 U.S. Gals. (265 liters).

Full Load Operating Time: 28.0 Hrs.

Starter: 12V Electric.

Standard Features: Muffler w/Guard and Weather Cap, DOC/DPF Exhaust After-Treatment System.

Engine Control Features: Padlockable Box with Throttle Control, Tachometer, Coolant Temperature, Oil Pressure, Voltage and Overstart Indicators/Shutdowns. Manual/Stop/Auto Keyswitch. Audible Startup Warning Delay. Fuel Level Display/Alarm/Shutdown. Electronic Fuel Level Sensor.

JOHN DEERE PUBLISHED PERFORMANCE:

Maximum Net Continuous BHP

74 (55 kW) @ 2400 RPM



GORMAN-RUPP PUMPS

www.grpumps.com

Specifications Subject to Change Without Notice

Printed in U.S.A.

Specification Data

SECTION 42, PAGE 223

APPROXIMATE DIMENSIONS and WEIGHTS

NET WEIGHT: 3310 LBS. (1501 KG.)
SHIPPING WEIGHT: 3590 LBS. (1628 KG.)
EXPORT CRATE SIZE: 273 CU. FT. (7,7 CU. M)

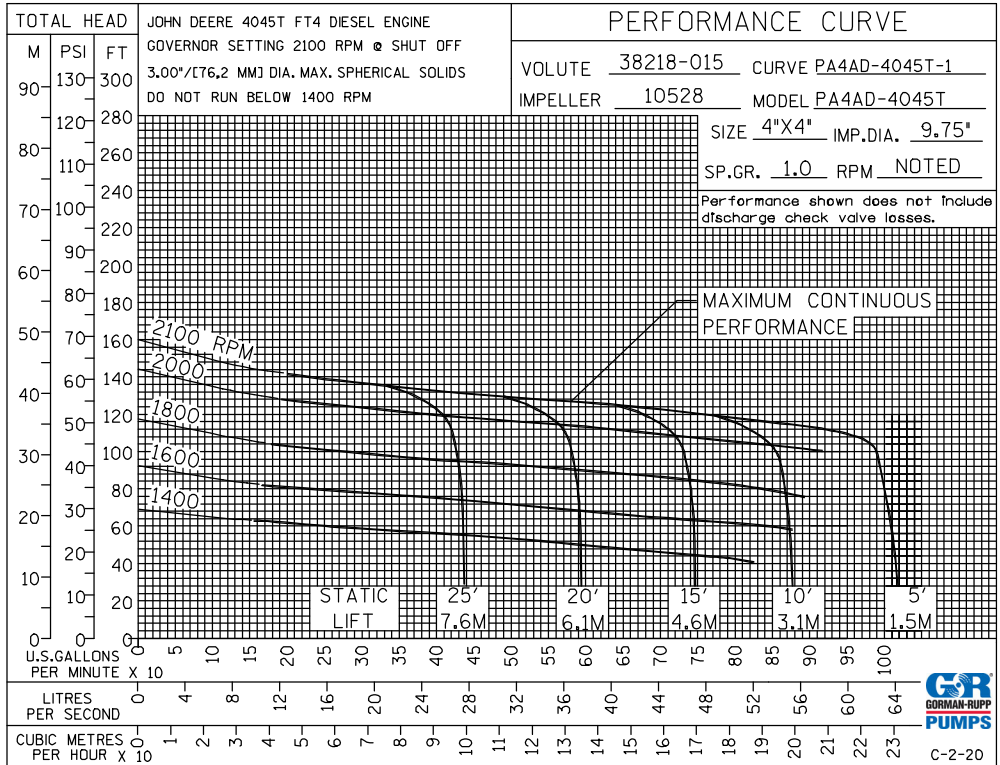
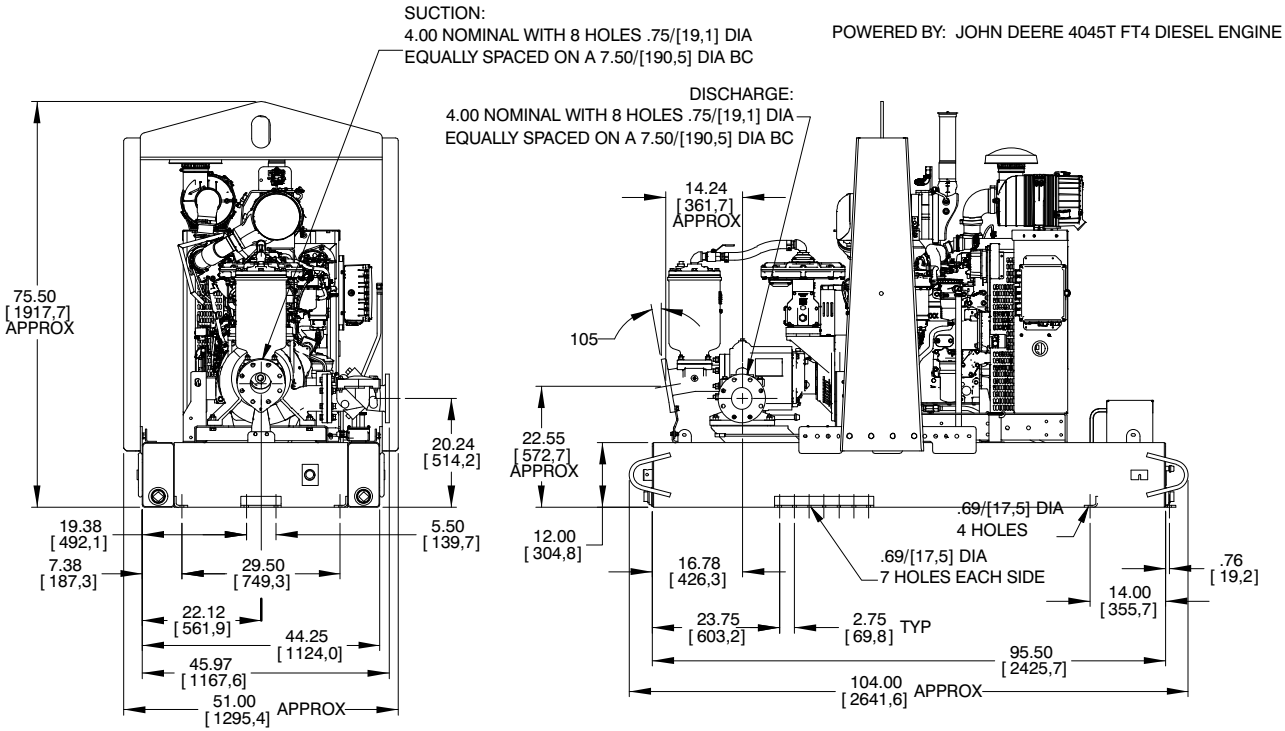

GORMAN-RUPP PUMPS

www.grpumps.com

Specifications Subject to Change Without Notice

Printed in U.S.A.