

Priming Assisted Centrifugal Pump



Model PAH16A60C-B

Size 18" x 16"



PUMP SPECIFICATIONS

- Size:** 18" x 16" (457 mm x 406 mm) Flanged.
- Casing:** Ductile Iron 65-45-12.
Maximum Operating Pressure 133 psi (917 kPa).*
- Enclosed Type, Four Vane Impeller:** Ductile Iron 80-55-06.
Handles 4" (101,6 mm) Diameter Spherical Solids.
- Suction Head:** Gray Iron 30.
- Suction Spool:** Gray Iron 30.
- Impeller Shaft:** Alloy Steel 4150M.
- Replaceable Wear Ring:** Ductile Iron 65-45-12.
- Bearing Pedestal:** Gray Iron 30.
- Seal Plate:** Ductile Iron 65-45-12.
- Shaft Sleeve:** Stainless Steel 303/304.
- Priming Chamber:** Gray Iron 30 Housing w/Stainless Steel Float and Linkage.
- Discharge Check Valve:** Ductile Iron Housing w/Buna-N Flapper.
- Radial Bearing:** Open Single Row Straight Roller.
- Radial/Thrust Bearing:** Open Double Row Tapered Roller.
- Bearing Cavity Lubrication:** Lithium EP2 Grease.
- Gaskets:** Resistant Synthetic Rubber, Vegetable Fiber w/Compressed Synthetic Fibers.
- O-Rings:** Buna-N.
- Hardware:** Standard Plated Steel.
- Seal Cavity Oil Level Sight Gauges.**

**Consult Factory for Applications Exceeding Maximum Pressure and/or Temperature Indicated.*

Standard Equipment: Belt Driven Air Compressor.

Optional Equipment: Base. NPT Threaded Flange Kit. Coupling. TEFC Motor. Suction Vacuum and Discharge Pressure Gauge Kit.



WARNING!

Do not use in explosive atmosphere or for pumping volatile flammable liquids.

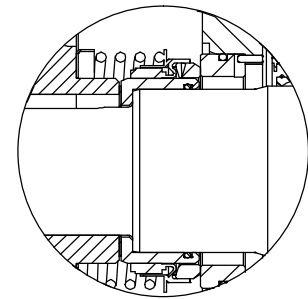
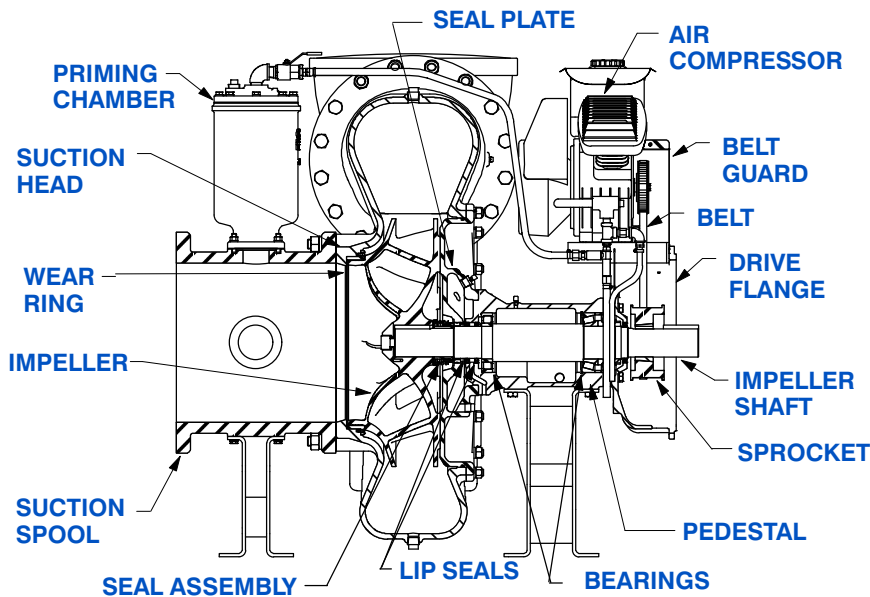

SEAL DETAIL

Mechanical, SAE 30 Non-Detergent Oil-Lubricated. Silicon Carbide Rotating Face and Stationary Seat. Fluorocarbon Elastomers (DuPont Viton® or Equivalent). Stainless Steel 316 Cage and Stainless Steel 18-8 Spring. Maximum Temperature of Liquid Pumped 160°F (71°C).*



GORMAN-RUPP PUMPS

www.grpumps.com

Specifications Subject to Change Without Notice

Printed in U.S.A.

Specification Data

APPROXIMATE
DIMENSIONS and WEIGHTS

NET WEIGHT:

4150 LBS. (1882 KG.)

SHIPPING WEIGHT:

4350 LBS. (1973 KG.)

EXPORT CRATE SIZE:

215 CU. FT. (6 CU. M.)

SECTION 43, PAGE 810

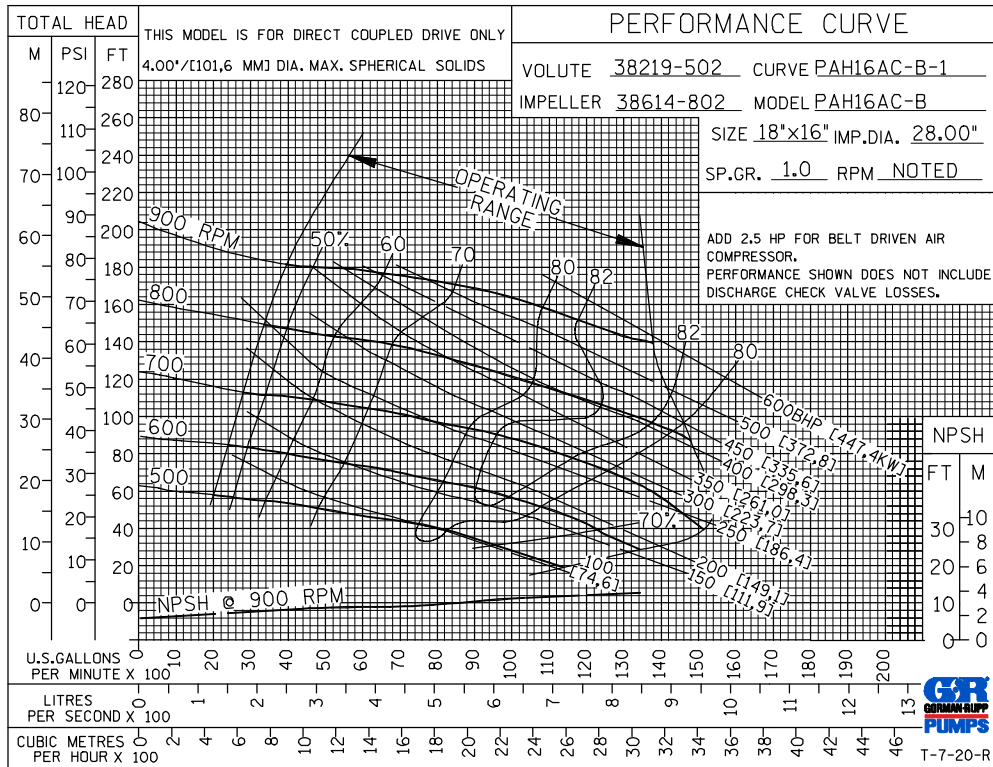
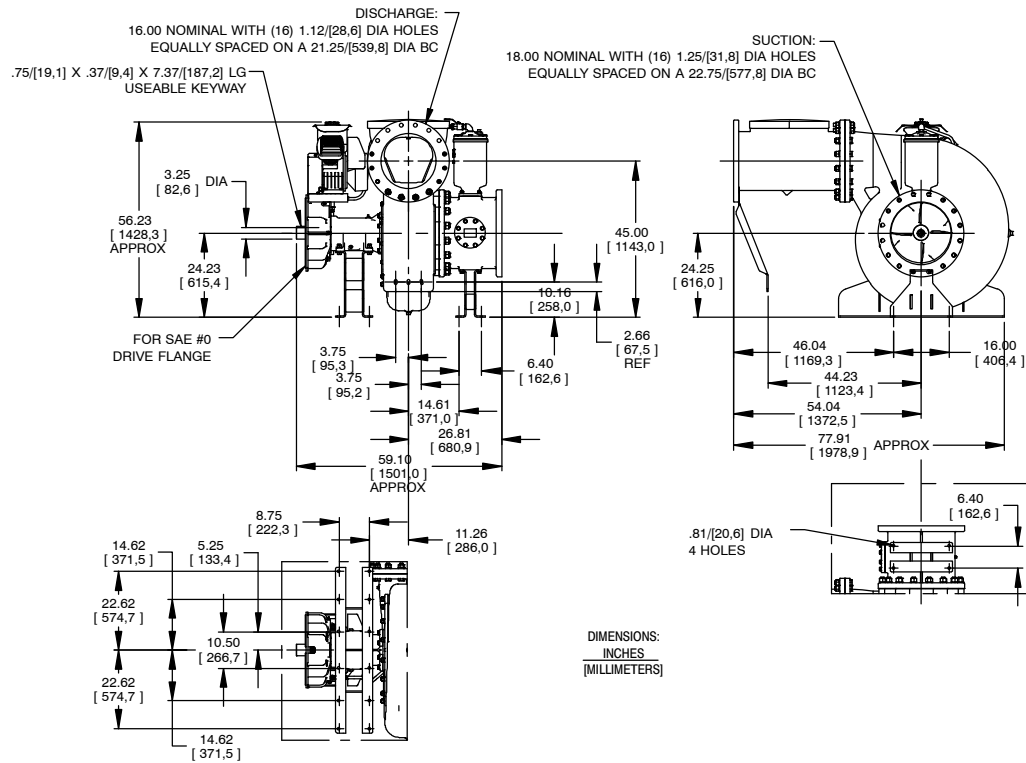

GORMAN-RUPP PUMPS

www.grpumps.com

Specifications Subject to Change Without Notice

Printed in U.S.A.