

Diesel Engine Driven Self Priming Centrifugal Pump w/Autostart

Model T6A60S-4045T FT4

Size 6" x 6"



Total Head		Capacity of Pump in U.S. Gallons per Minute (GPM) at Continuous Performance			
P.S.I.	Feet				
59.0	136	400	400	400	400
52.0	120	730	760	760	760
43.3	100	750	1050	1170	1170
34.7	80	760	1060	1290	1460
26.0	60	770	1070	1300	1500
17.3	40	780	1080	1310	1510
Suction Lift		25'	20'	15'	10'



PUMP SPECIFICATIONS

Size: 6" x 6" NPT (152 mm x 152 mm) - Female.
Casing: Gray Iron 30. Maximum Operating Pressure 98 psi (675 kPa).*
Semi-Open Type, Two Vane Impeller: Ductile Iron 65-45-12.
 Handles 3" (76.2 mm) Diameter Spherical Solids.
Impeller Shaft: Stainless Steel 17-4 PH.
Replaceable Wear Plate: Carbon Steel 1015.
Removable Adjustable Cover Plate: Gray Iron 30; 50 lbs. (23 kg).
Flap Valve: Neoprene w/Steel Reinforcing.
Seal Plate: Gray Iron 30.
Shaft Sleeve: Alloy Steel 4130.
Seal: Cartridge Type, Mechanical, Oil-Lubricated, Double Floating, Self-Aligning. Silicon Carbide Rotating and Stationary Faces. Stainless Steel 316 Stationary Seat. Fluorocarbon Elastomers (DuPont Viton® or Equivalent). Stainless Steel 18-8 Cage and Spring. Maximum Temperature of Liquid Pumped 160°F (71°C).*
Bearing Housing: Gray Iron 30.
Radial Bearing: Open Single Ball.
Thrust Bearing: Open Double Ball.
Bearing and Seal Cavity Lubrication: SAE 30 Non-Detergent Oil.
Flanges: 125# Gray Iron 30.
Gaskets: Buna-N, Compressed Synthetic Fibers, PTFE, Vegetable Fiber, Cork, and Rubber.
O-Rings: Buna-N.
Hardware: Standard Plated Steel.
Brass Pressure Relief Valve.
Bearing and Seal Cavity Oil Level Sight Gauges.
**Consult Factory for Applications Exceeding Maximum Pressure and/or Temperature Indicated.*
Standard Equipment: Hoisting Bail. 90° Discharge Elbow. Single Ball Type Float Switch. [Full Feature Control Panel](#)**
Optional Equipment: Battery. G-R Hard Iron Impeller and Seal Plate. Hardened Steel Wear Plate. High Speed (55 MPH/89 KM/H) Single Axle Pneumatic-Tired Wheel Kit w/wo DOT-Approved Lights and Electric Brakes. [Over-the-Road Trailer](#) (Meets DOT Requirements) Available w/ Either Electric or Hydraulic Surge Brakes, Running Lights, Jack Stands and Safety Cables/Chains.
****50 Ft. (15 m) Standard Length; Dual Switches and Alternate Cable Lengths Available From the Factory.**

WARNING!

Do not use in explosive atmosphere or for pumping volatile flammable liquids.

ENGINE SPECIFICATIONS

Model: John Deere 4045T.
EPA Tier: Final Tier 4.
Type: Four Cylinder, Four Cycle, Turbocharged, Liquid Cooled Diesel Engine.
Displacement: 276 Cu. In. (4,5 liters).
Lubrication: Forced Circulation.
Air Cleaner: Dry Type.
Fuel Tank: 88 U.S. Gals. (330 liters).
Full Load Operating Time: 23.5 Hrs.
Starter: 12V Electric.
Standard Features: Muffler w/Guard and Weather Cap, DOC/DPF Exhaust After-Treatment System.
Optional: Electronic Fuel Level Sensor.
Engine Control Features: Padlockable Box with Throttle Control, Tachometer, Coolant Temperature, Oil Pressure, Voltage and Overstart Indicators/Shutdowns. Manual/Stop/Auto Keyswitch. Audible Startup Warning Delay. Fuel Level Display/Alarm/Shutdown (For Use With Optional Fuel Level Sensor).

JOHN DEERE PUBLISHED PERFORMANCE:
 Maximum Gross Continuous BHP (Industrial)
 72 (54 kW) @ 2400 RPM



GORMAN-RUPP PUMPS

www.grpumps.com

Specifications Subject to Change Without Notice

Printed in U.S.A.

Specification Data

SECTION 45, PAGE 1562

APPROXIMATE
DIMENSIONS and WEIGHTS

NET WEIGHT:
SHIPPING WEIGHT:
EXPORT CRATE SIZE:

SKID BASE

2-WHEEL

3395 LBS. (1540 KG.)

3905 LBS. (1771 KG.)

3630 LBS. (1646 KG.)

3905 LBS. (1771 KG.)

273 CU. FT. (7,7 CU. M.)

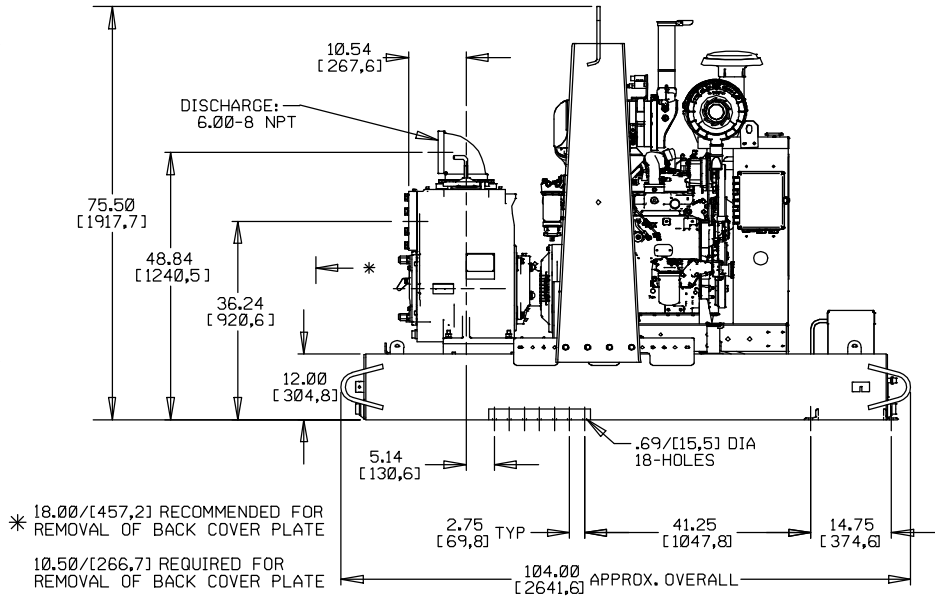
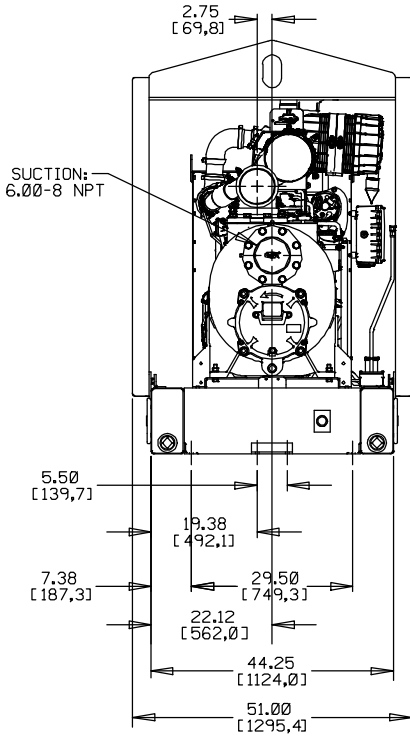

POWERED BY JOHN DEERE 4045T FT4 ENGINE

DIMENSIONS:
INCHES
[MILLIMETERS]

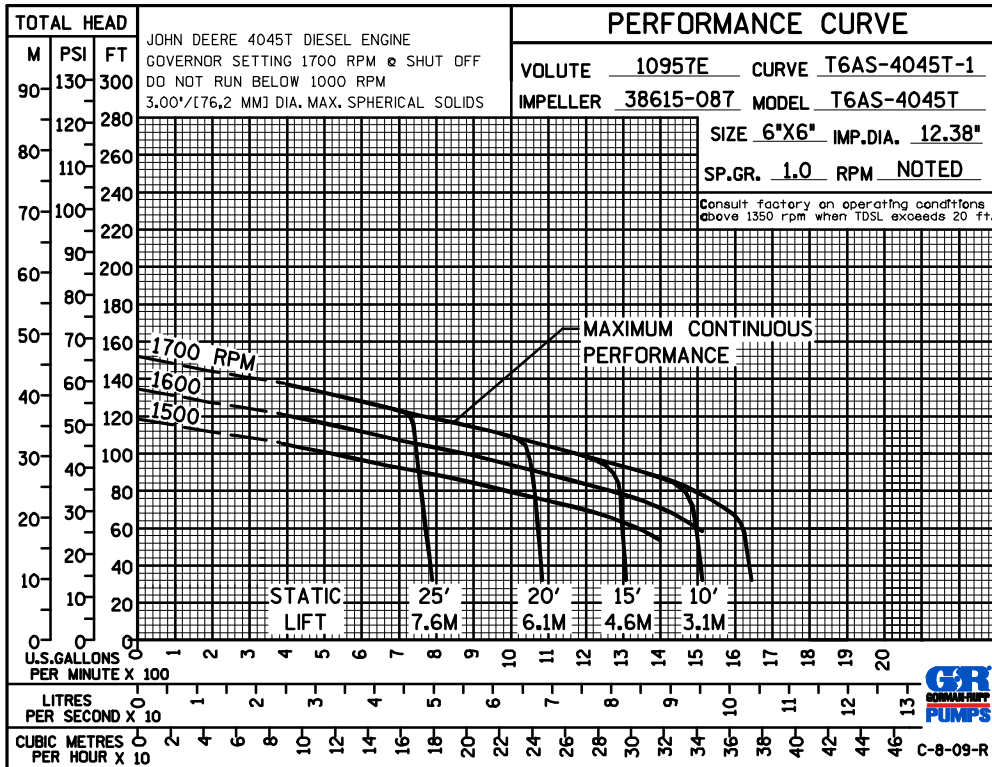

GORMAN-RUPP PUMPS

www.grpumps.com

Specifications Subject to Change Without Notice

Printed in U.S.A.