

Self Priming Centrifugal Pumps

Ultra V Series[®] Basic Pump^{w/}UltraMate[®] Second Stage



Model VS6A60-B

Size 8" x 6"



VARIOUS PATENTS APPLY

PUMP SPECIFICATIONS

- Size:** 8" x 6" (203 mm x 154 mm) – Flanged.**
- Casings:** Upper - Ductile Iron 65-45-12. Lower - Gray Iron 30.
Maximum Casing Pressure 257 psi (1772 kPa).*
- Maximum Operating Pressure 250 psi (1723 kPa) at Temperatures up to 100 F (37 C) Based on System Component Limitations.*
- Semi-Open Type, Two Vane Impellers:** Ductile Iron 65-45-12.
Handles 3" (76,2 mm) Diameter Spherical Solids.
- Impeller Shafts:** Alloy Steel 4150.
- Self-Cleaning Replaceable Wear Plates:** Carbon Steel ASTM A36.
- Shimless Adjustable Cover Plates:** Gray Iron 30.
- Removable Inspection Cover Plate:** Gray Iron 30; 13 lbs. (5,9 kg.).
- Suction Flange:** Gray Iron 30.
- Bearing Housings:** Gray Iron 30.
- Seal Plates:** Gray Iron 30.
- Shaft Sleeves:** Alloy Steel 4130.
- Radial and Thrust Bearings:** Open Double Row Ball.
- Bearing and Seal Cavity Lubrication:** SAE 30 Non-Detergent Oil.
- Gaskets:** Buna-N, Compressed Synthetic Fibers, Vegetable Fiber, PTFE, Cork, and Rubber.
- O-Rings:** Buna-N.
- Transition Chamber:** Ductile Iron 65-45-12.
- Hardware:** Standard Plated Steel.
- Brass Pressure Relief Valves.**
- Bearing and Seal Cavity Oil Level Sight Gauges.**
- Optional Equipment:** [Suction Vacuum and Discharge Pressure Gauge Kit.](#)
[Drain Pump Kit.](#) [Automatic Air Release Valve.](#) High Pump Temperature Shutdown Kit. Stainless Steel/G-R Hard Iron Impellers, Wear Plates and Seal Plates. 120/240 Volt Casing Heater.
- ** Optional Gray Iron 30 Flange Kits Available as Follows (See Price Sheets):
8" and 6" Female NPT Suction/Discharge Flange Kits.
8" and 6" ASA Suction/Discharge Spool Flange Kits.
200 mm and 150 mm DIN 2527 (PN 16) Suction/Discharge Spool Flange Kits.

UltraMate[®]
Second
Stage

Ultra V
Basic
Pump

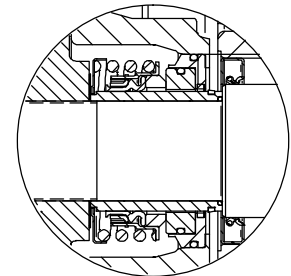
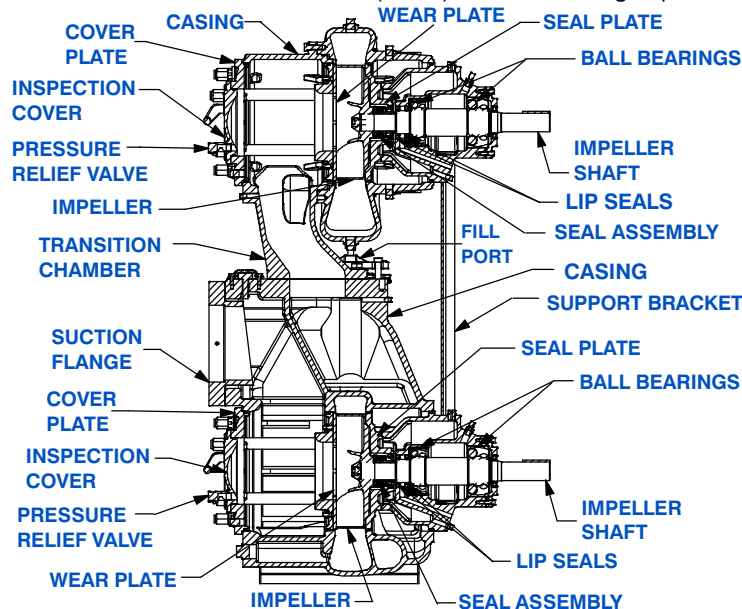

SEAL DETAIL

Cartridge Type, Mechanical, Oil-Lubricated, Double Floating, Self-Aligning. Silicon Carbide Rotating and Stationary Faces. Stainless Steel 316 Stationary Seat. Fluorocarbon Elastomers (DuPont Viton[®] or Equivalent). Stainless Steel 18-8 Cage and Spring. Maximum Temperature of Liquid Pumped, 160°F (71°C).*

* Consult Factory for Applications Exceeding Maximum Pressure and/or Temperature Indicated.



GORMAN-RUPP PUMPS

www.grpumps.com

Specifications Subject to Change Without Notice

Printed in U.S.A.

Specification Data

SECTION 55, PAGE 3200

APPROXIMATE DIMENSIONS and WEIGHTS

NET WEIGHT: 1900 LBS. (862 KG.)*
SHIPPING WEIGHT: 1975 LBS. (896 KG.)*
EXPORT CRATE: 74 CU. FT. (2,1 CU. M.)
***WEIGHTS DO NOT INCLUDE OPTIONAL FLANGE KITS**

OPTIONAL SUCTION & DISCHARGE FLANGES SHOWN IN PHANTOM

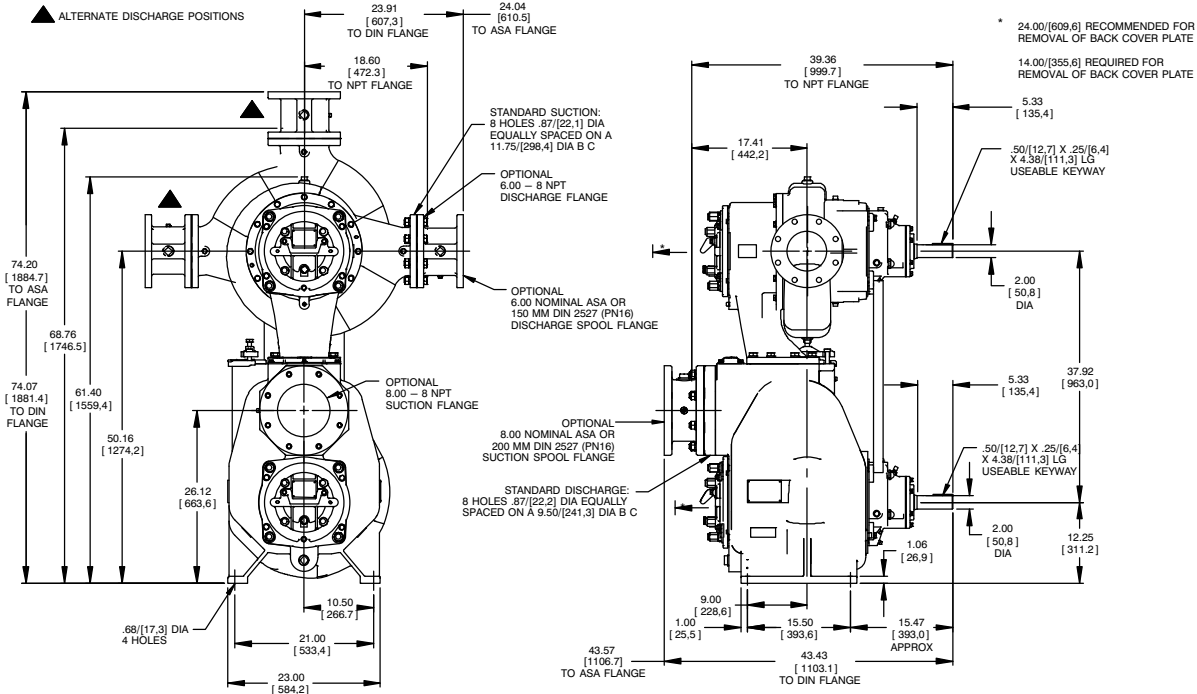

MULTI-SPEED CURVE PERFORMANCE BASED ON WATER

TOTAL COMBINED H.P. SHOWN

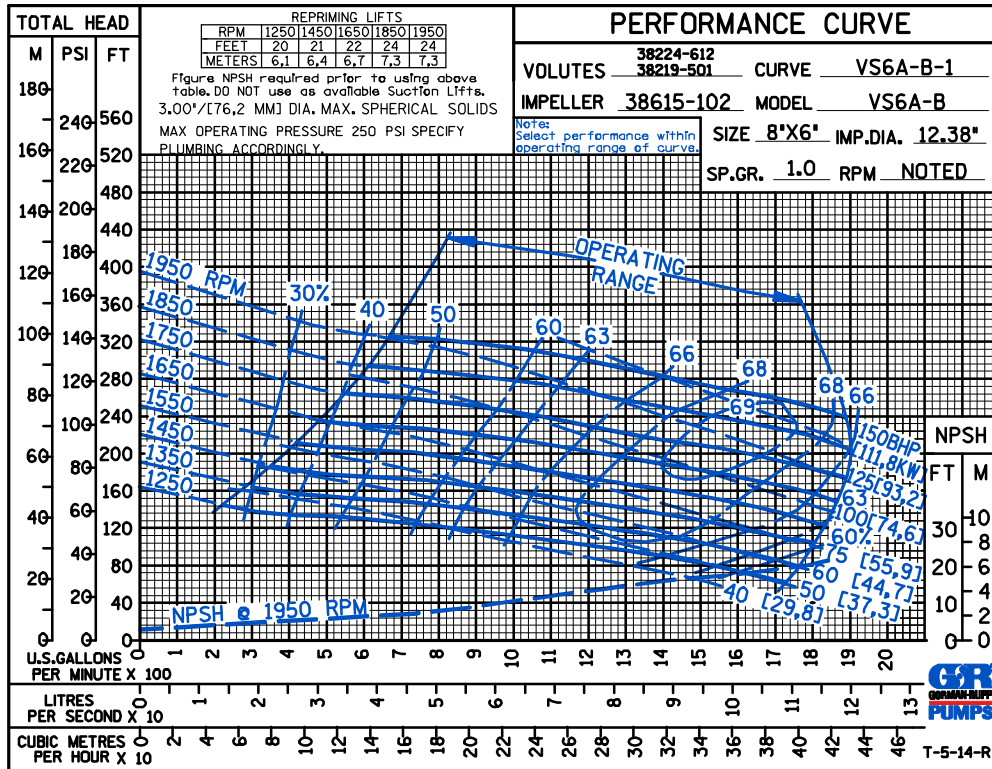

GORMAN-RUPP PUMPS

www.grpumps.com

Specifications Subject to Change Without Notice

Printed in U.S.A.

**MULTI-SPEED
CURVE
PERFORMANCE
BASED ON
WATER**

**TOTAL
COMBINED
H.P. SHOWN**

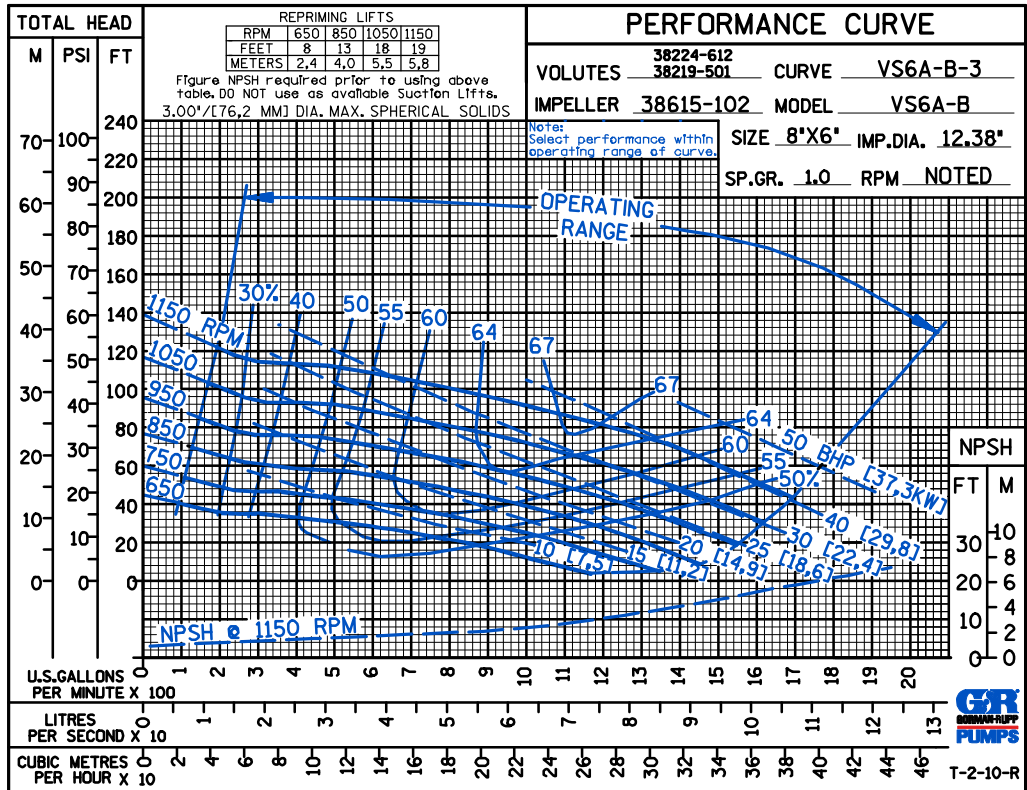

GORMAN-RUPP PUMPS

www.grpumps.com

Specifications Subject to Change Without Notice

Printed in U.S.A.