

Electric Motor Driven, Stainless Steel

Submersible Pump

Model S4C65-E10

Size 4"



PUMP SPECIFICATIONS

Diffuser: Stainless Steel CD4MCu;

Maximum Operating Pressure 69 psi (476 kPa).*

Impeller: Stainless Steel CD4MCu.

Wear Plate: Stainless Steel CD4MCu.

Seal Plate: Stainless Steel CD4MCu.

Intermediate: Stainless Steel 316.

Casing: Stainless Steel 316.

Motor Housing: Stainless Steel 316.

Motor Shaft: Stainless Steel 316.

Shaft Sleeve: Stainless Steel 316.

Bearings: Upper - Open Single Row Ball Bearing.

Lower - Two Synthetic Seals, Double Row Ball Bearing.

Discharge Flange: Stainless Steel 316.

Gaskets: Buna-N with Compressed Synthetic Fiber.

O-Rings: Fluorocarbon (DuPont Viton® or Equivalent).

Wetted Hardware: Stainless Steel 316.

Strainer: Stainless Steel 316; 50.6% Open Area,

0.375" (9,5 mm) Diameter Openings.

Hoisting Bail: Stainless Steel 316.

Standard Equipment

NEMA Type 3R Rainproof Control Box. *(See Section 130, Page 90.)*

Provides On-Off, Circuit Breaker and Motor Overload Protection.

Optional Equipment

Liquid Level Control: *(See Sec. 130, Page 150.)*

a. Turtle Type Pressure Activated Level Switch.

b. Float Activated Level Switch.

Staging Adapter Kit.

MOTOR/CABLE SPECIFICATIONS

Motor: Oil Filled Enclosure; 10.0 H.P.; 3450 R.P.M.; Three Phase: 460/575

Volt, 60 Hz, 17/13.6 Full Load AMPS, 12.2 kW (Max.)

Power Cable: CPE/CSPE Jacket, Type GGC; 6 Wire; 8 AWG.

3 Power Conductors, 2 Ground Conductor and 1 Ground Check.

(Specify Alternate Length at Time of Order.)

Recommended Generator Size: 15 kW Across the Line Start.

* *Consult Factory for Applications Exceeding Maximum Pressure and/or Temperature Indicated.*

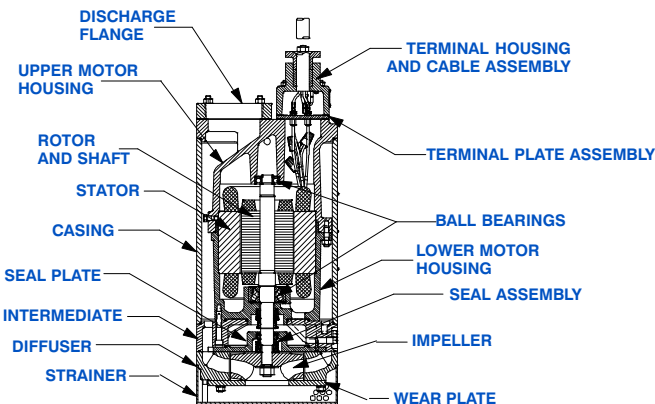
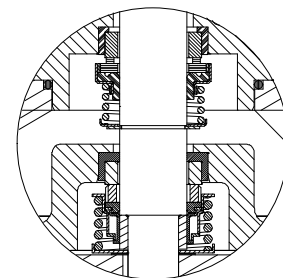

SEAL DETAIL

Tandem, Oil Lubricated.

Upper Seal: Type 21, Mechanical. Carbon Rotating Face. Ceramic Stationary Face. Buna-N Elastomers. Stainless Steel 18-8 Cage and Spring.

Lower Seal: Type 2, Mechanical. Silicon Carbide Rotating and Stationary Faces. Fluorocarbon Elastomers (DuPont Viton® or Equivalent). Stainless Steel 303/304 Cage and Spring.

Maximum Temperature of Liquid Pumped, 122°F (50°C).*



GORMAN-RUPP PUMPS

www.grpumps.com

Specifications Subject to Change Without Notice

Printed in U.S.A.

Specification Data

SECTION 130, PAGE 880

APPROXIMATE
DIMENSIONS and WEIGHTS

NET WEIGHT: 385 LBS. (174,6 KG.)
SHIPPING WEIGHT: 405 LBS. (183,7 KG.)
EXPORT CRATE: 16.2 CU. FT. (0,46 CU. M.)

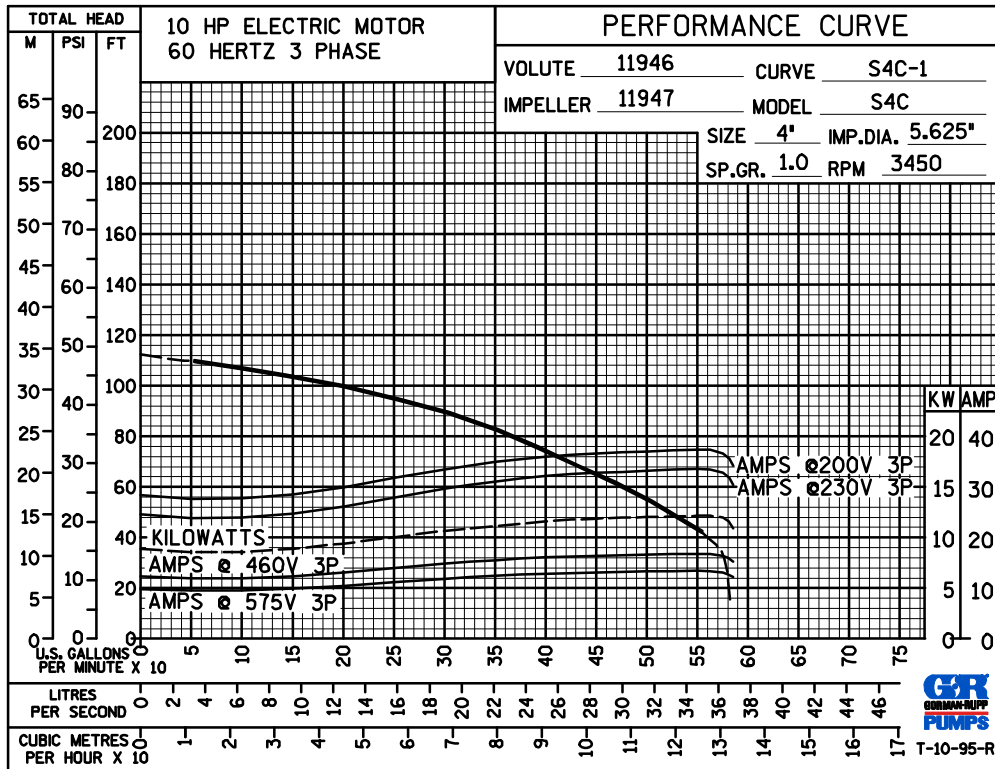
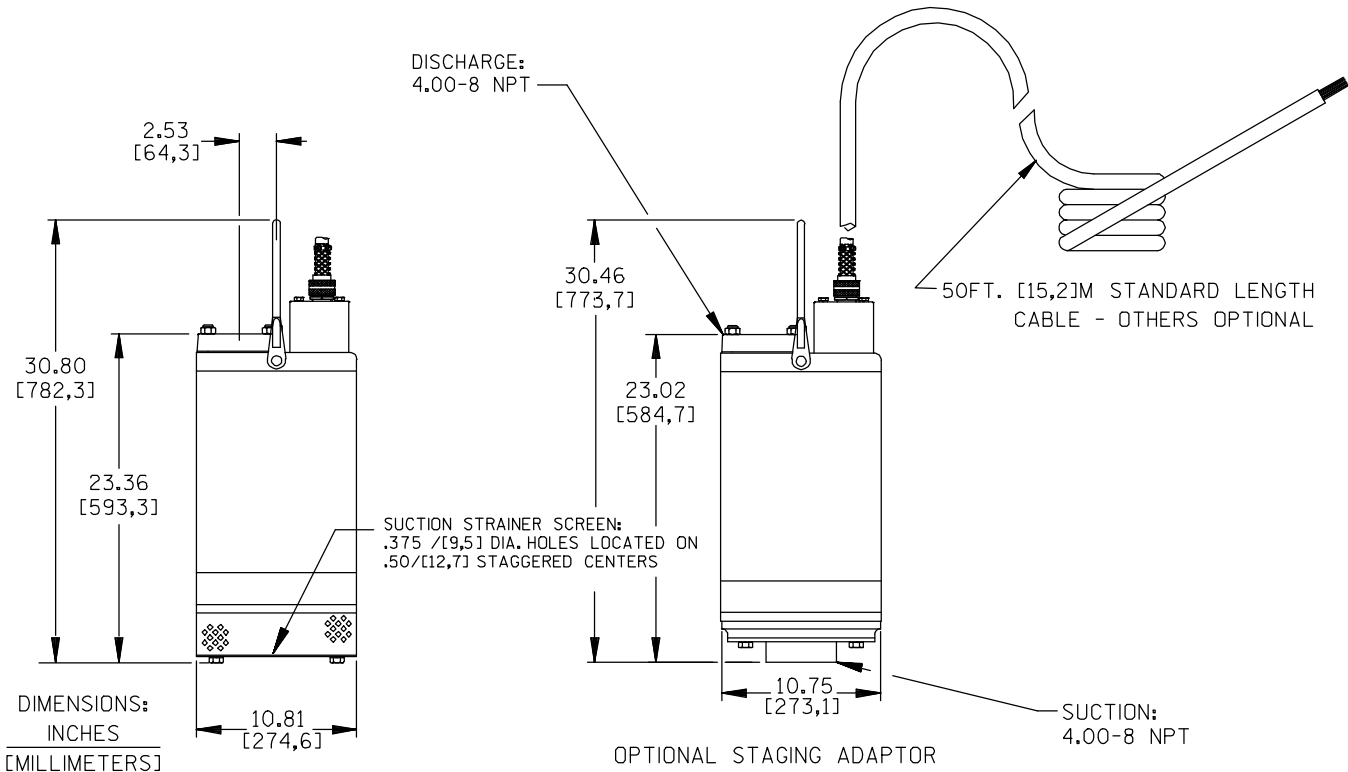

GORMAN-RUPP PUMPS

www.grpumps.com

Specifications Subject to Change Without Notice

Printed in U.S.A.