

# SUBMITTAL DATA SHEET

Sump, Sewage, & Effluent Pumps  
DuraMAC™ | Guardian

## 5020PUUP Utility Pump



See Pumps & Accessories  
Price List for Limited  
Warranty details.

This pump can handle up to 26 gallons per minute. With a tough thermoplastic construction and a sleek design that allows the pump to fit in a 6" opening.

### Utility Pump Performance Curve

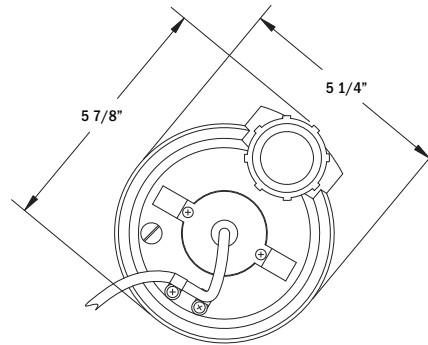
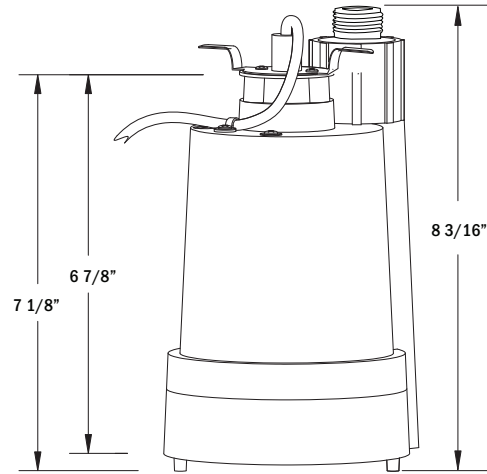
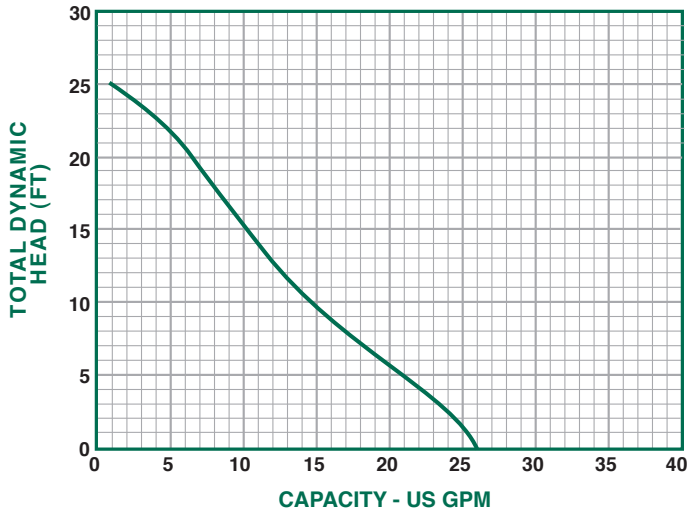

### PERFORMANCE CHART

| Model    | Gallons per Minute in Feet |    |    |    |    |    |
|----------|----------------------------|----|----|----|----|----|
|          | 0                          | 5  | 10 | 15 | 20 | 25 |
| 5020PUUP | 26                         | 21 | 14 | 10 | 7  | 1  |

### SUBMERSIBLE PLASTIC UTILITY PUMP - 1 1/4" DISCHARGE

| Model    | HP  | Volts | Hz | Amps | Construction  | Discharge Size | Cord Length | Solids Handling | RPM  | Phase |
|----------|-----|-------|----|------|---------------|----------------|-------------|-----------------|------|-------|
| 5020PUUP | 1/5 | 120   | 60 | 3.6  | Thermoplastic | 1 1/4"         | 10'         | 1/8"            | 3450 | 1     |

### SUBMITTAL INFORMATION

- Split Capacitor Motor - 1/5 HP continuous duty, thermal protected
- Lifts water up to 25' of vertical height
- 10' Power Cord
- 3/4" Garden hose adapter included
- Large 1 1/4" discharge for high capacity pumping



NO-LEAD: The weighted average of the wetted surface of this no-lead product contacted by consumable water contains less than one quarter of one percent (0.25%) lead.



A.Y. McDonald Mfg. Co.  
P.O. Box 508  
Dubuque, IA 52004-0508

Toll Free: 1-800-292-2737  
Fax: 1-800-832-9296  
Hours: 7:00 a.m. - 5:00 p.m., CST

sales@aymcdonald.com  
www.aymcdonald.com

A.Y. McDonald considers the information on this assembly drawing correct when published. Item and option availability, including specifications, are subject to change without notice.

Submitted by: