

SUBMITTAL DATA SHEET

Irrigation & Booster Pumps Superbooster | Centrifugal

8600SW Series - Convertible Centrifugal Pumps



The convertible centrifugal pump is ideal for lawn sprinkling, garden irrigation, pool filling, draining, cooling towers, and other water transfer applications. The square flange construction has a high service factor rating for continuous operation. The 8600SW pump has a capacity to 65 gallons per minute (GPM), and requires no maintenance.

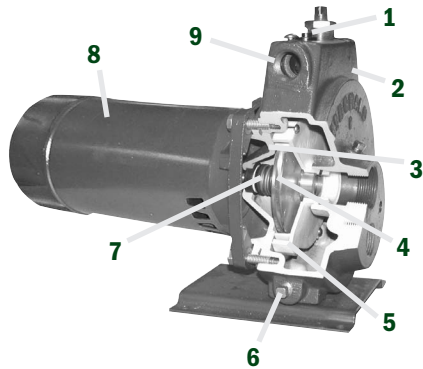

- 1 - Internal Regulating Valve**
(Manual adjustment for deep well only)
- 2 - Cast Iron Pump Body**
- 3 - Seal / Condensation Plate**
Provides air gap between motor & water chamber
- 4 - Impeller**
Available in engineered polycarbonate thermoplastic
- 5 - Diffusers**
Multi-volute engineered thermoplastic diffuser for maximum capacity and pressure
- 6 - Drain Plug**
- 7 - Shaft Seal**
Standard 5/8" ceramic carbon rotating mechanical seal
- 8 - High Service Factor, Capacitor Start, Threaded Shaft, Square Flange Motor**
Built to Nema specifications by nationally known manufacturers to assure local service availability. Choice of 1/3, 1/2, 3/4, & 1 HP. 50 Hz. or 60 Hz.
- 9 - Zinc Plated Plug**
(With Pressure Gauge Tap and 1/4" plug)

Performance

Model No.	HP	Suction Lift-FT.	Capacities in GPM at Discharge Pressure							Maximum Shut Off Pressure PSI / FT.
			5# / 12'	10# / 23'	15# / 35'	20# / 46'	25# / 58'	30# / 69'	35# / 81'	
8650SW	1/2	10	52	49.5	47	39.5	25	10.8	--	34# / 78'
		20	46.5	45.5	40.5	28	11.5	--	--	30# / 69'
8670SW	3/4	10	60	60	57.8	56	51.5	40	--	38# / 88'
		20	52	52	52	50	41	19.3	--	34# / 78'
8610SW	1	10	65	65	62.8	60.8	57	50	41.5	42# / 97'
		20	54	54	53.5	52.5	48	41	26	38# / 88'

Specifications

Model	HP	Volts	Pipe Sizes		Shipping Weight
			Suction	Discharge	
8650SW	1/2	115 / 230	1 1/4"	1"	40#
8670SW	3/4	230 / 115	1 1/4"	1"	42#
8610SW	1	230 / 115	1 1/4"	1"	46#

- Suction pipe = 1 1/4" NPT. For best results increase to 2" NPT within 6" of pump intake.
- Discharge pipe = 1" NPT. For best results increase to 1 1/2" NPT within 6" of pump outlet using priming plug opening.
- Maximum allowable operating pressure = 100 PSIG (as a booster pump, for example).

Note: Standard 8600 series pumps, with pressure switch, may also be used with these applications and if the 3/4" top discharge tapping is increased to 1 1/2" NPT similar, but slightly less, capacity will be obtained.

SUBMITTAL INFORMATION

- Self-priming under normal conditions
- Time proven 5/8" mechanical seal
- Pressure to 40 PSI / 92 feet head
- For shallow wells, lakes, streams, or booster systems

NO-LEAD: The weighted average of the wetted surface of this no-lead product contacted by consumable water contains less than one quarter of one percent (0.25%) lead.



A.Y. McDonald Mfg. Co.
P.O. Box 508
Dubuque, IA 52004-0508

Toll Free: 1-800-292-2737
Fax: 1-800-832-9296
Hours: 7:00 a.m. - 5:00 p.m., CST

sales@aymcdonald.com
www.aymcdonald.com

A.Y. McDonald considers the information on this assembly drawing correct when published. Item and option availability, including specifications, are subject to change without notice.

Submitted by: