

# Balcrank

## 1-1/2" CENTER FLO PUMP CF65 (65 g/min)

Operation and maintenance manual

Codes:

**1120-033**

### Content

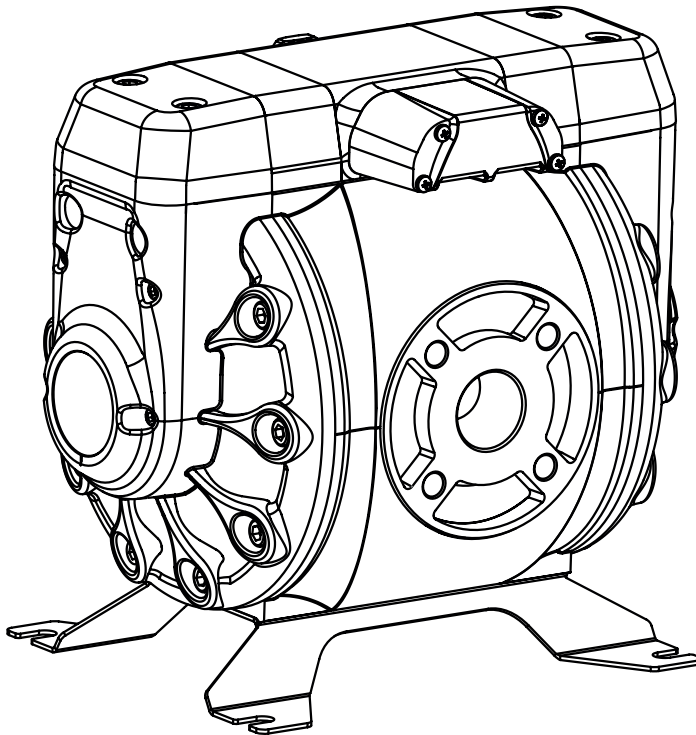

|                        |   |
|------------------------|---|
| Content                | 1 |
| Technical data         | 1 |
| Warnings and cautions  | 2 |
| Description            | 2 |
| Capacity curves        | 3 |
| Dimensions             | 3 |
| Installation           | 4 |
| Operating instructions | 5 |
| Pump repair kits       | 6 |
| Composite body parts   | 7 |
| Troubleshooting        | 8 |
| Repair and maintenance | 9 |

### Technical data

|  | <b>CF65</b>                                 |
|--|---|
| Ratio  | <b>1:1</b>                                  |
| Maximum free flow  | <b>66.04 US gal/min (250 l/min)</b>         |
| Delivery per stroke  | <b>20.9 oz (0.62 l)</b>                     |
| Air pressure operating range                                   | <b>22 to 102 psi (1,5 a 7 bar)</b>          |
| Solid in suspension max size                                   | <b>0.2-0.24 in (5-6 mm)</b>                 |
| Maximum suction head   | <b>16.5 ft (5 m) dry, 26.2 ft (8 m) wet</b> |
| Weight   | <b>44.09 lb (20 kg)</b>                     |
| Fluid inlet (single inlet)                                     | <b>NPT (F) + ANSI B16.5 150 lb</b>          |
| Fluid outlet   | <b>NPT (F) + ANSI B16.5 150 lb</b>          |
| Air inlet  | <b>1/2" NPSM (F)</b>                        |
| Wetted part materials  | <b>Acetal, SS, NBR, Zinc plated CS, POM</b> |
| Noise level  | <b>80 dB</b>                                |
| Temperature range, (see material temperature range on page 2). | <b>32 - 158 °F (0 - 70 °C)</b>              |

2015\_06\_09-11:40

## Warnings and cautions

In this document you will find warnings and cautions for installation, use and maintenance of the Center Flo pumps.



This symbol indicates that there is a danger of serious bodily injury or death if you ignore the warning described.

Here's the meaning of symbols you may find in this document and general warnings that you should keep in mind.



This symbol indicates that there is a danger of personal injury or property damage if you ignore the caution described.



### Carefully read the instructions and warnings before operating the equipment!

- This equipment is for professional use only.
- Do not degrade the integrity of the equipment. Use only original replacement components from Balcrank.
- Fluids not suitable for the pump can cause damage to the pump unit and involve risk of serious personal injury.
- Always consult Balcrank. if you have any questions about the compatibility within the fluids and the pump materials, including elastomers.
- Install and use the pump according to all local and national regulations and abide all health and safety laws or legislation.
- The pump can produce fluid pressures equal to the air supply pressure. Do not exceed the maximum allowable pressure of 100 psi (7 bar) air supply. The total hydraulic pressure (differential pressure + system) should never exceed 100 psi (7 bar).
- Never use a pump that leaks, that is damaged, that is corroded or otherwise it may lack the capacity to contain the fluid.
- Frequently check that the bolts on the diaphragm cover of the pump are torqued correctly. (See torque specs in the repair and maintenance section).

Do not use a model with aluminium wetted surfaces to pump fluids for human consumption, there is a possibility of trace contamination of lead. Danger of explosion if used 1,1,1-trichloroethane, methylene chloride or other halogenated hydrocarbon solvents with aluminium wetted materials. It could cause serious injury and property damage.

Inside the pump, diaphragms separate the fluid that is being pumped from the air supply. If a diaphragm breaks, the fluid can leak out of the air exhaust and contaminate the environment.

When handling hazardous fluids, always route the air exhaust into a suitable container and locate it in a safe place.

When the fluid source level is situated higher than the pump, (flooded suction), the outlet tank must be at a higher level than the product to prevent spills.

For pumps handling hazardous fluids that are a danger to humans or to the environment, install a suitable container surrounding the pump to prevent any leaks or spills.

Ensure that the operators of this equipment are trained on the operation and limitations. Use safety equipment as safety goggles or other equipment required.

## Description

Air operated double diaphragm pumps are air-powered, reciprocating positive displacement pumps with two pumping chambers. Two diaphragms, centrally located in the chambers, separate the compressed air (dry side) from the fluid being pumped (wet side). A shaft transmits the reciprocating motion of one diaphragm to the other. A directional valve alternatively distributes the air from one chamber to the other; thus

a reciprocating movement of the diaphragms is created. With each stroke, fluid is discharged by one of the diaphragms whilst the opposite diaphragm sucks new fluid into the expanding chamber. Check valves, two on the discharge side and two on the suction side, control and direct the fluid flow.

## Capacity curves

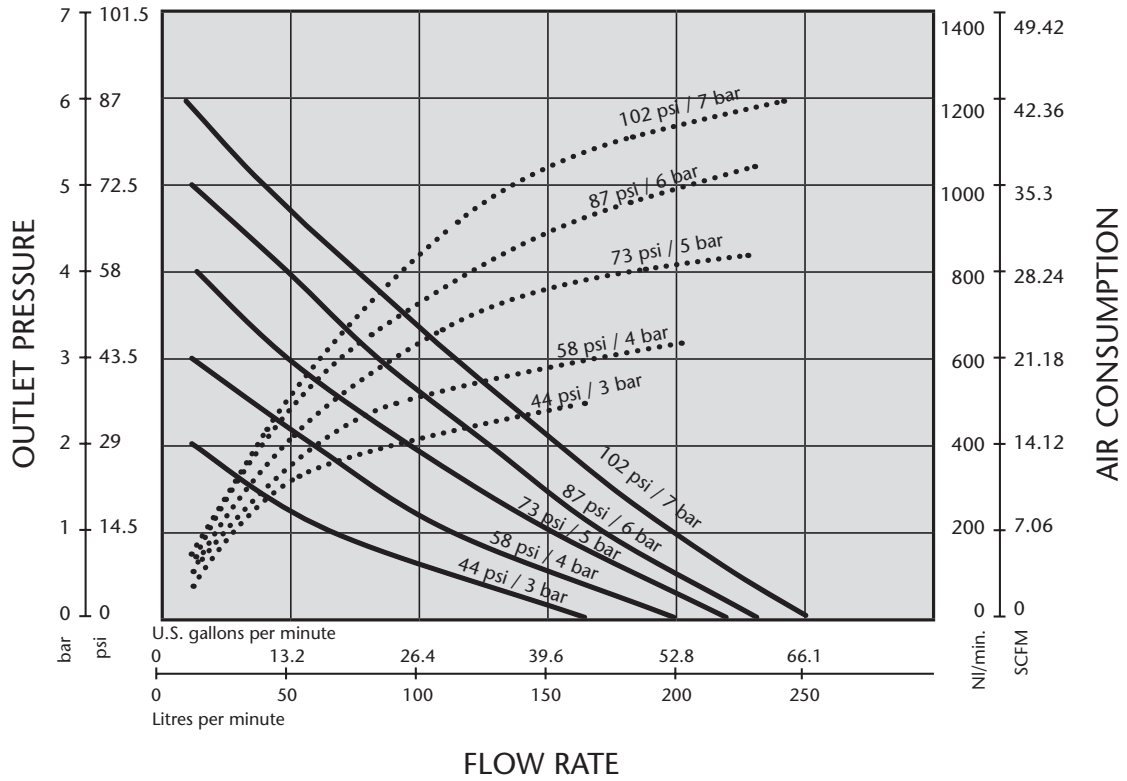

\*Tested at room temperature, using water. Flooded pump with 3.5 inches (80 mm), positive suction head.

## Dimensions

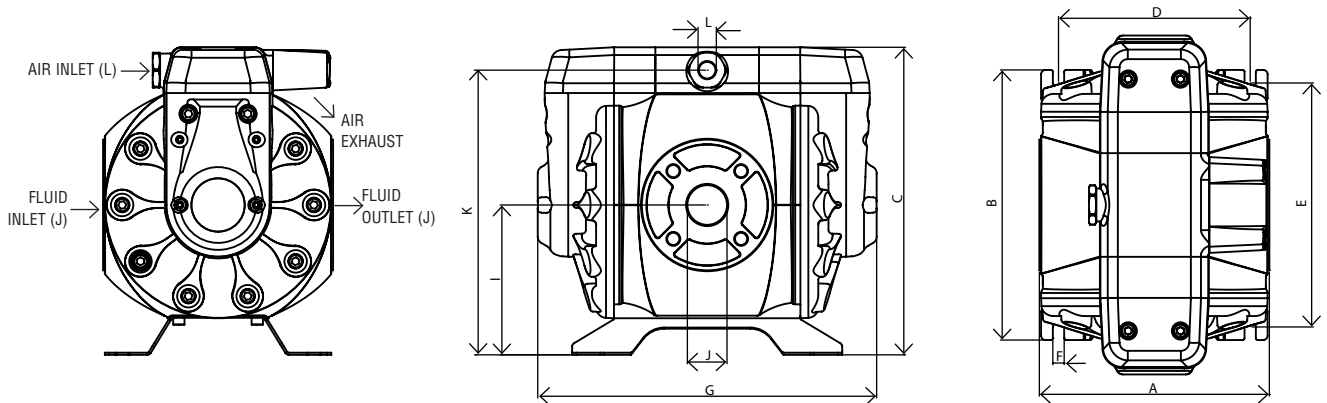

2015\_06\_09-11:40

| CF65   |        |        |        |        |       |        |        |                |       |               |
|--------|--------|--------|--------|--------|-------|--------|--------|----------------|-------|---------------|
| A      | B      | C      | D      | E      | F     | G      | I      | J              | K     | L             |
| 264 mm | 310 mm | 353 mm | 220 mm | 280 mm | 13 mm | 390 mm | 172 mm | 1-1/2" NPT (F) | 327   | 1/2" NPSM (F) |
| 10.39" | 12.2"  | 13.9"  | 8.66"  | 11.02" | 0.51" | 15.35" | 6.77   |                | 12.87 |               |

## Installation

### Installation recommendations

- Remove the pump from its package and install it on the chosen location.
- Try to minimize the suction head. Install the pump as close as possible to the fluid being pumped.
- Remember to have enough space around the pump to perform maintenance tasks.
- Keep in mind to connect the inlet and outlet of the pump correctly.
- In case of diaphragm pump failure, the air exhaust will expell the product being pumped.
- When the pump is installed in a place where a spill of fluid can cause an environmental impact, the exhaust should be directed to a place where this spill could be contained.
- When installing the pump in its place, use brackets to secure its base.
- Fasten all bolts with the torques contained in this manual.

**CF pumps are very easily configured and easy to install.**

**Flooded:**

The pumping system was designed with positive pressure at the inlet. This is the best possible installation when you need to evacuate the liquid from the drum or tank, or when working with viscous fluids.

Not recommended for hazardous fluids.

**Self-priming:**

Pump is designed to generate vacuum. It is possible to evacuate all the air from a hose or pipe without damaging the pump. Maximum suction height is 19.69 ft (6 m), with the suction hose empty and up to 26.25 ft (8 m) with the hose primed. (See page 1 for corresponds suction lift).

**Submerged:**

All pumps can be immersed in fluids. It is important to verify that all components that are in contact with the fluid are chemically compatible. In this case, air exhaust and fluid must be carried by hoses (optional air connection).

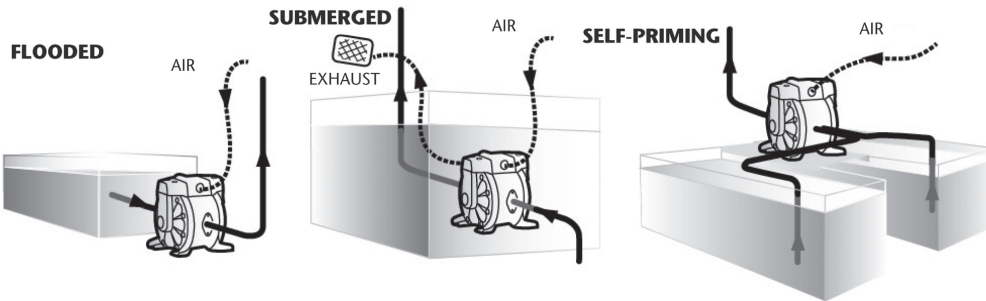

**NOTE:** Use a pressure regulator with built-in filter inlet.

**NOTE:** The compressed air supply must be between 43.5 psi (3 bar) and 100 psi (7 bar).

### Recommended installation

The figure below shows the recommended configuration for the installation of a diaphragm pump. Read the warnings and recommendations of the previous page before starting.

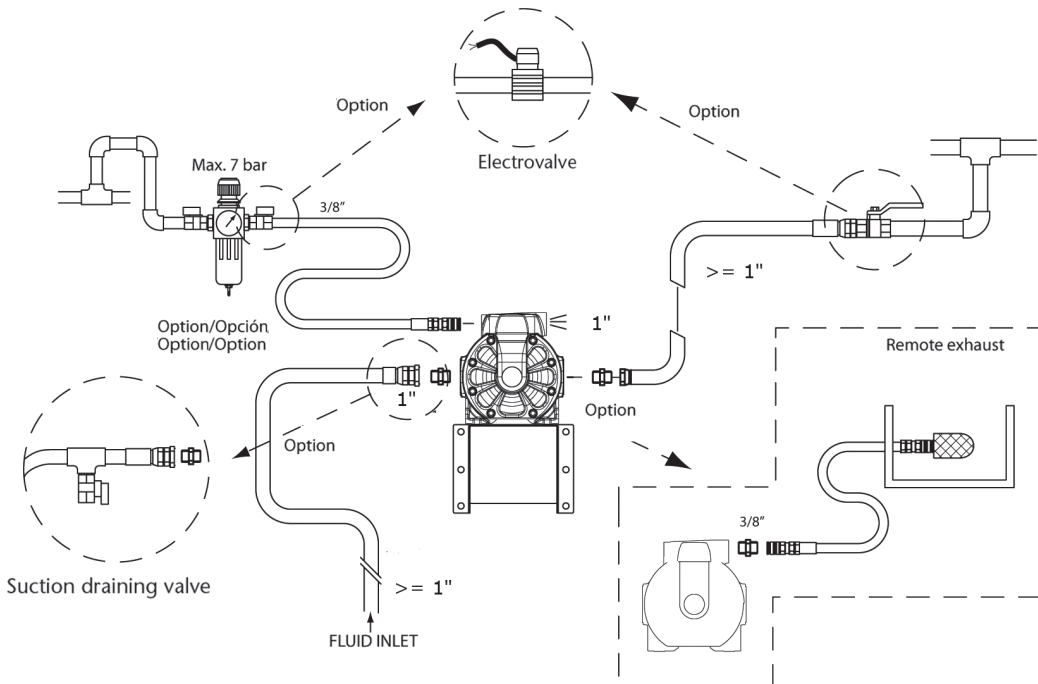

2015\_06\_09-11:40

## Installation

### Air exhaust disposal

#### Warning

The pump exhaust should be directed to a safe place, away from people, animals and food.

- Remove the muffler.
- Connect a hose to the exhaust port of the pump and install the muffler at the end of the hose. Use a hose with the same diameter as the exhaust port. If the hose is more than 5 feet (1.5 m), consult your dealer.
- Have a protective housing, etc. at the end of the hose.

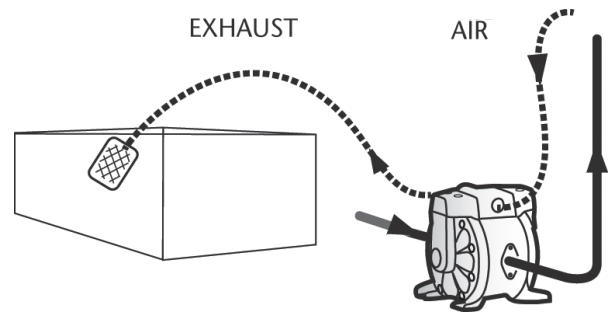

#### Warning

### Air connection

To ensure that the air supply is sufficient to meet the demand of the pump, the diameter of the pipe must be equal to the diameter of the supply port of the pump. Choose auxiliary air treatment equipment and fittings with sufficient airflow to exceed the air consumption of the pump.

In addition, peripheral air treatment equipment must be installed as close as possible to the pump unit.

The use of a coupler to connect the hoses aids future operation and maintenance tasks.

## Operating instructions

### This pump is self-priming.

To prime it the first time, you must connect the air pump supply to a low pressure using the pressure regulators while keeping the outlet valve open. When fluid begins to flow from the pump outlet, the pump is primed. For

regulation of fluid pressure, the unit must be supplied with an air pressure between 43.5 and 100 psi (3 and 7 bar). Adjust the discharge valve on the discharge side to control flow. For the performance characteristics of the pump see the capacity curve shown on page 3.

### Stopping the pump

- Close the inlet valve of the pump and stop the air supply.
- Make sure for your safety that the air valve is closed.
- Turn off the air compressor, or close the valve on the air supply side of the auxiliary equipment.
- Close the discharge valve on the discharge side, then begin to slowly open the drain valve and discharge pressure fluid.
- Open the air valve of the pump, turn on the pump and flush the remaining fluid.
- After ensuring that the pump was turned off and the pressure was released, fully open and close the regulator valve and drain valve of the pump.

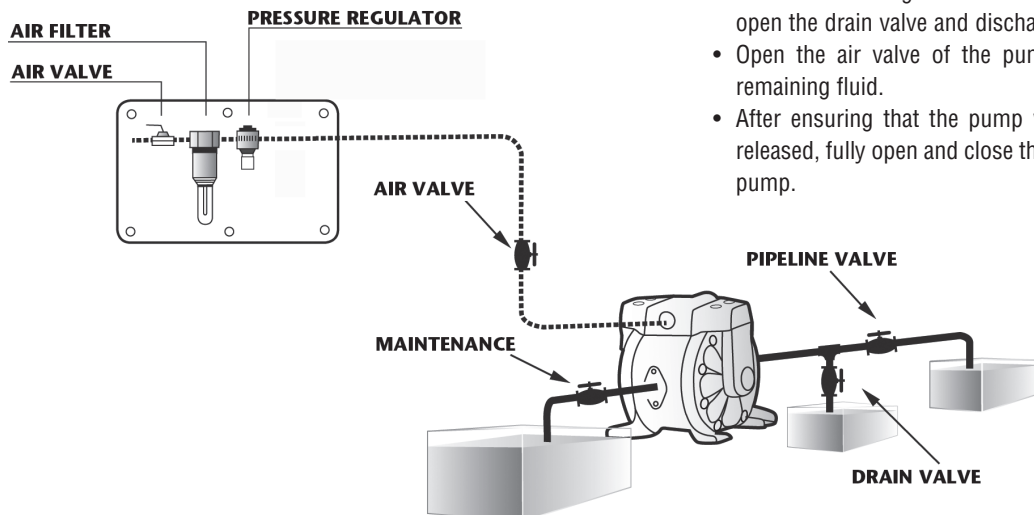

2015\_06\_09-11:40

## Operating instructions

### Grounding the pump

STICKER THAT SHOWS THE POSITION OF THE GROUND WIRE

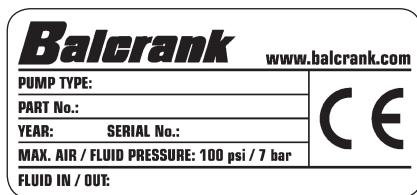
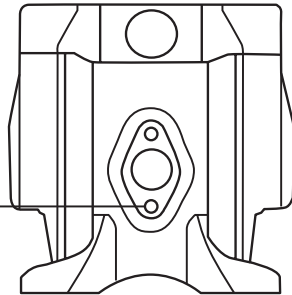



- When installing the pump, be sure to perform grounding in the specified location.
- Also connect ground wires for the auxiliary equipment and piping.
- Use a grounding cable of at least 12 gauge (2.0 mm<sup>2</sup>).

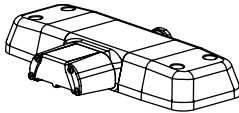
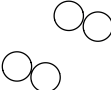
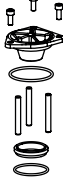

- Connect grounding wires to the pump, piping and all other equipment too.
- When the pump operates ungrounded or with an incorrect connection, friction between parts and abrasion caused by some fluids that flow inside the pump, can generate static electricity. Moreover, according to the type of fluid pump and the installation environment (such as gases in the air or the type of the surrounding facilities) static electricity can cause fire or electric shock.

### 1120-033 CF65 Repair kits

| CF65  | 1-1 through 1-9   |        | 2   |        | 3-1 through 3-4   |        |
|---|---|--------|---|--------|---|--------|
|   | Directional valve   | Part # | Balls   | Part # | Ball valves seats / Seals / Cages   | Part # |
|   | Standard  | 833431 | Acetal  | 833433 | Stainless steel / NBR / Zinc plated carbon steel                                      | 833434 |
|  |  |        |  |        |  |        |

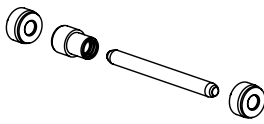
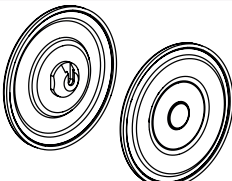
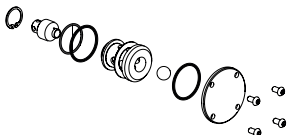
| CF65  | 4-1 through 4-5   |        | 5-1 through 5-2  |        | 6-1 through 6-8   |        |
|---|---|--------|--|--------|---|--------|
|   | Bushing / Seals / Shaft   | Part # | Diaphragms   | Part # | Air sensor  | Part # |
|   | POM/ NBR/ Stainless steel   | 833435 | HYTREL   | 833436 | Standard  | 833432 |
|  |  |        |  |        |  |        |

2015\_06\_09-11:40

# Composite body pump parts

CF65

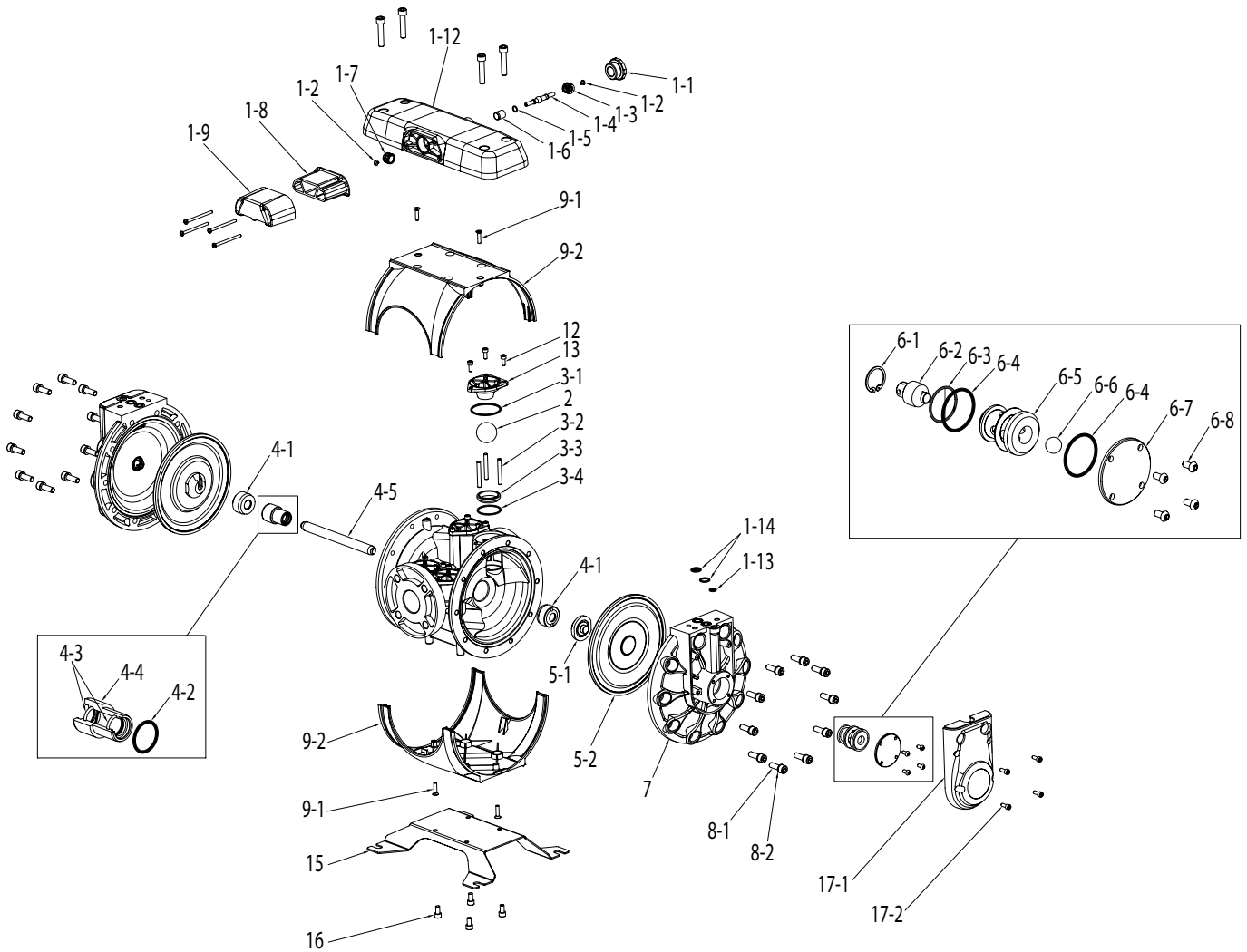

| No. | Description                              | Qty.  | Part # |
|-----|--|-------|--------|
| 1   | Directional Valve                        | 1     | 833431 |
| 2   | Balls                                    | 4     | 833433 |
| 3   | Ball check seats / O-rings / Ball guides | -     | 833434 |
| 4   | Bushing / Seal / Push rod                | -     | 833435 |
| 5   | Diaphragms                               | 2     | 833436 |
| 6   | Air sensors                              | -     | 833432 |
| 7   | Diaphragm cover                          | 2     |        |
| 8   | Diaphragm lid bolts / Spring Washers     | 20/20 |        |
| 9   | Pump shields                             | 2     |        |
| 12  | Valves cap bolts                         | 8     |        |
| 13  | Valves caps                              | 2     |        |
| 14  | Body                                     | 1     |        |
| 15  | Pump support                             | 1     |        |
| 16  | Support bolts                            | 4     |        |
| 17  | Cover / Cover screws                     | 2/8   |        |

2015\_06\_09-11:40

## Troubleshooting

| Cause   | Recommended measure   |
|---|---|
| <b>The pump does not work</b>   |   |
| The discharge valve on the discharge side is not open.                      | Open the discharge valve on the discharge side.   |
| No air supply.  | Turn on the compressor and open the air valve and air regulator.  |
| The air supply pressure is low.   | Check the compressor and the configuration of the air line.   |
| Air leaks in connecting elements.   | Check the connection elements and the tightening of the screws.   |
| The air pipes or ancillary equipment is clogged with mud.                   | Check and clean the air line.   |
| The exhaust port (muffler) of the pump is clogged with mud.                 | Check and clean the exhaust port and muffler.   |
| The fluid pipe is clogged with mud.   | Check and clean the fluid line.   |
| Pump is clogged with mud.   | Remove, inspect and clean the pump body.  |
| <b>The pump runs but no fluid comes out</b>                                 |   |
| The valve on the suction side is not open.                                  | Open the valve on the suction side.   |
| Too much suction or discharge height.                                       | Confirm the configuration of the pipe and reduce the height of the same.  |
| Fluid pipe discharge side (including the filter) is clogged with mud.       | Check and clean the fluid line.   |
| Pump is clogged with mud.   | Dismantle the pump, check and clean.  |
| The ball and ball seat is worn or damaged.                                  | Inspect and replace parts.  |
| <b>The flow is decreasing</b>   |   |
| The air supply pressure is low.   | Check the compressor and the configuration of the air line.   |
| The air line or peripheral equipment clogged with mud.                      | Check and clean the air line.   |
| Valve discharge side drive will not open normally.                          | Adjust the discharge valve discharge side.  |
| The air mixes with the fluid.   | Replenish fluid and check the configuration of the pipe on the suction side.  |
| Cavitation occurs.  | Adjust air supply pressure and discharge pressure and reduce the suction.   |
| Vibrations.   | Adjust air supply pressure and discharge pressure. Reduce the flow of the inlet valve to adjust pressure and volume of fluid.                     |
| Ice formation in the air exhaust.   | Remove ice from the air bypass valve and check and clean the air filter. Use a pipe in the exhaust air that the ice does not form in the muffler. |
| The fluid line (including the filter) plugged with mud.                     | Check and clean the fluid pipe and strainer.  |
| The exhaust port (muffler) of the pump is clogged with mud.                 | Check and clean the exhaust port and muffler.   |
| Pump is clogged with mud.   | Remove, inspect and clean the pump body.  |
| <b>Leakage of fluid through the hollow exhaust (silencer)</b>               |   |
| The diaphragm is damaged.   | Remove and inspect the pump and replace the diaphragm.  |
| <b>Irregular noise</b>  |   |
| The air supply pressure is too high.  | Adjust air supply pressure.   |
| The pump is clogged with sludge particles larger than the diameter allowed. | Remove, check and clean the pump body.  |
| <b>Irregular vibration</b>  |   |
| The elements of connection and the support of the pump are loose.           | Review each element of connection and tighten the screws.   |
| The air supply pressure is too high.  | Adjust air supply pressure.   |
| The range and ball valve vibrates.  | Adjust air supply pressure and exhaust pressure.  |
| <b>In fluid with air bubbles</b>  |   |
| Diaphragm damaged.  | Replace diaphragm.  |
| Suction hose loose or broken.   | Tighten or replace.   |
| <b>Powered air leak pressure of 3 to 7 bar</b>                              |   |
| Wear directional valve.   | Replace directional valve components.   |
| <b>No start-up and is leaking air without cycles</b>                        |   |
| Stiff air sensors.  | Change air sensor.  |
| Wear directional valve.   | Replace.  |

2015\_06\_09-11:40



**Torques necessary for the proper functioning of the pump**

For proper operation of the pump and to prevent accidents which may damage equipment and in the worst case, people, you must periodically review the torques of the diaphragms covers and the DIRECTIONAL VALVE. In the next table are shown the appropriate torques for this purpose:

|                     |                   |                                 |
|---------------------|-------------------|---------------------------------|
| Torques <b>CF65</b> | Diaphragm cover   | 177 to 260 lbf-in (20 to 30N-m) |
|                     | Directional valve | 132 lbf-in (15 N-m)             |
|                     | Valve cap         | 70 lbf-in (8 N-m) composite     |

**Diaphragm replacement**

**Before any intervention: DISCONNECT AIR SUPPLY OF THE PUMP.  
IT IS NOT NECESSARY TO REMOVE THE PUMP FROM THE FLUID LINE.**

1. Close fluid valves.
2. Drain the fluid inside the pump. Anticipate a drainage of fluid from inside the pump.
3. Remove the directional valve while being careful not to damage the seals shown in the figure.
4. Remove the diaphragm cap.

**NOTE: To tighten these screws you must use a torque wrench calibrated to (see torque table in this page).**

5. Remove the cover by gently pulling back.
  6. Remove the used diaphragm and place the new one in the proper position.
- Assemble components.

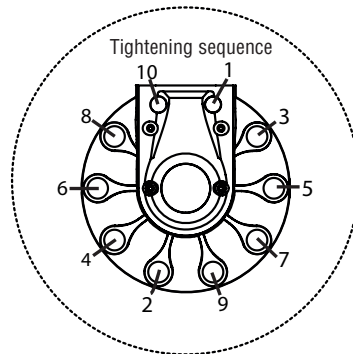

When reassembling the diaphragm lid with its nuts, please follow the torque sequence as shown in the picture. It is crucial to not use the required torque values until the diaphragm lid is fully approximated to the central body using the screws.

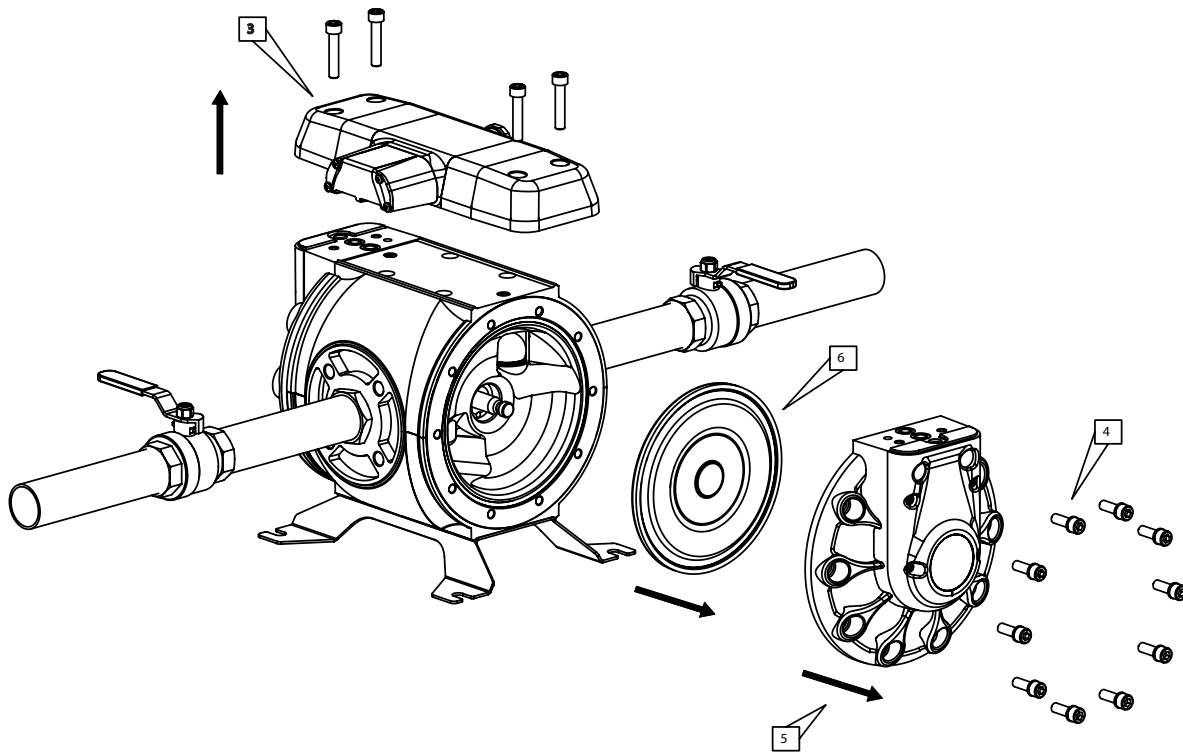

2015\_06\_09-11:40

Pushing rod

Remove the side cover on the right of the fluid inlet as shown in the figure, following the procedure to "Replace diaphragms".

Once the shaft is visible, use the following procedures:

1. Remove the shaft from its housing by pulling it from one end.  
The Teflon® sleeve is threaded into the body. To remove use snap ring pliers in the two holes indicated in the figure.
2. Once the cap has been removed, remove the quad ring inside the pump body.
3. Replace the kit following the correct order shown in the assembly drawing.

Reassemble the pump in reverse order.

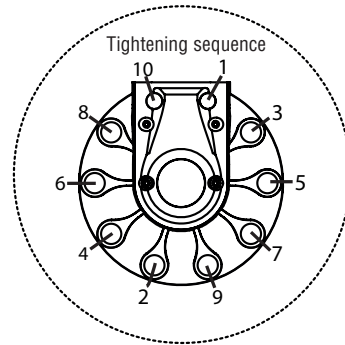

When reassembling the diaphragm lid with its nuts, please follow the torque sequence as shown in the picture. It is crucial to not use the required torque values until the diaphragm lid is fully approximated to the central body using the screws.

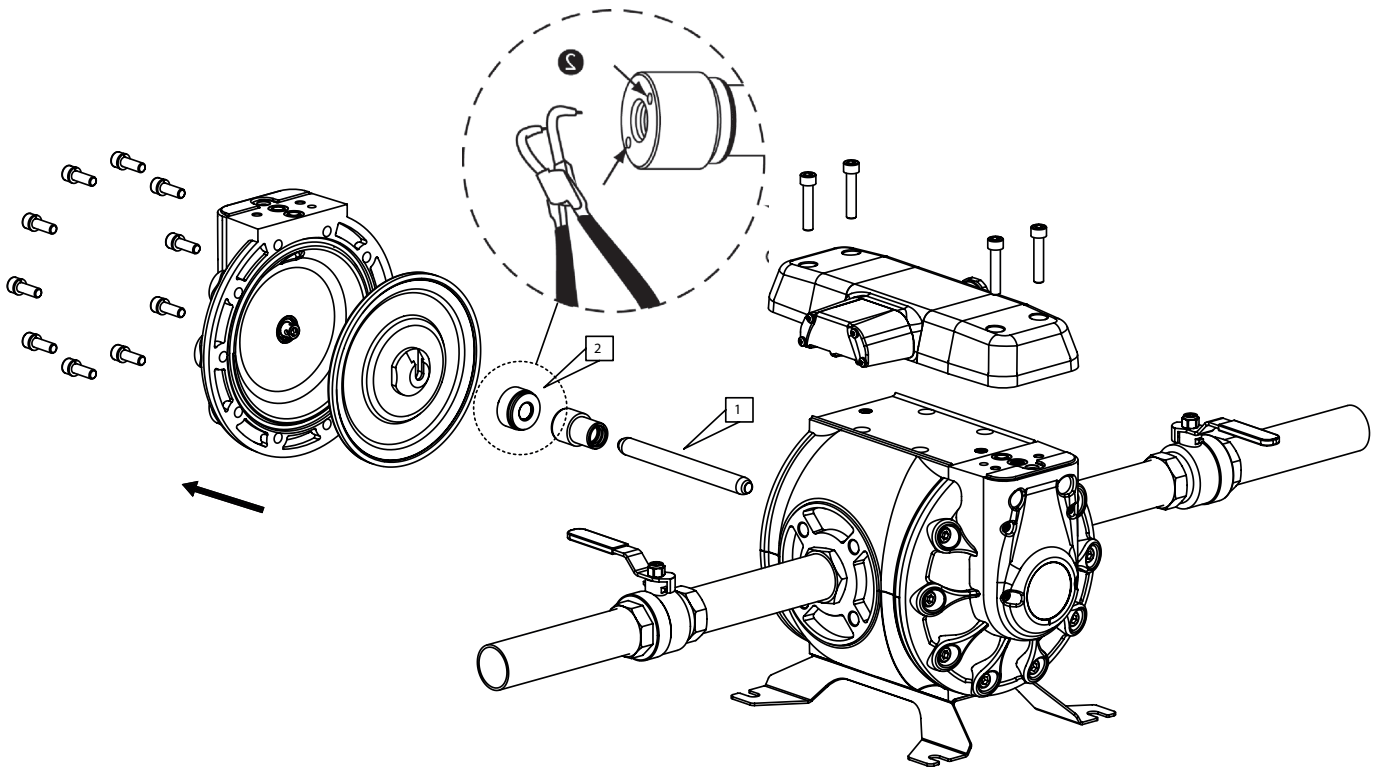

2015\_06\_09-11:40

**Ball valves replacement**

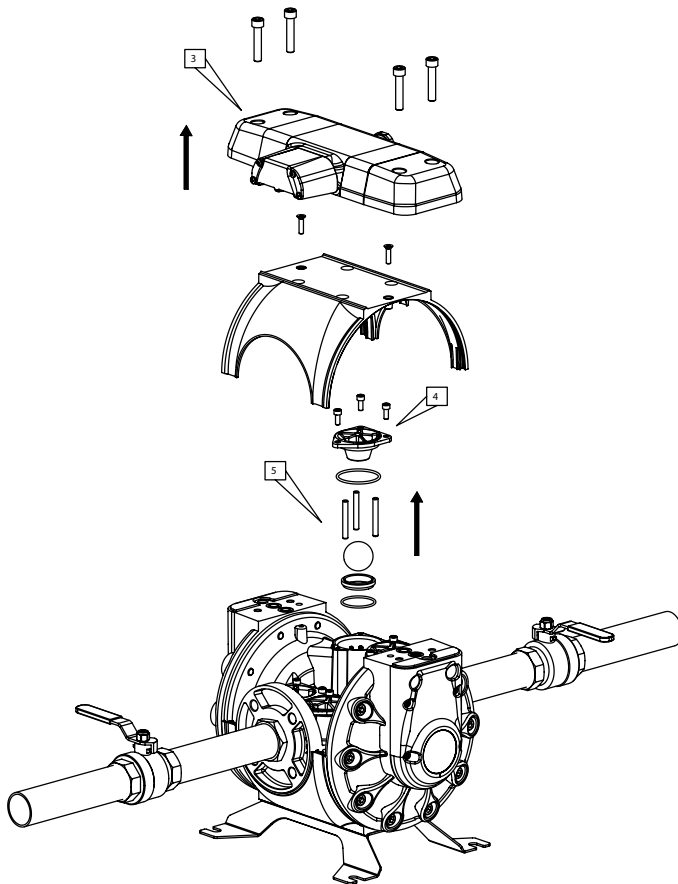

1. Close fluid valves.
2. Drain the fluid from inside the pump. Anticipate a drainage of fluid from inside the pump.
3. Loosen the screws to remove the directional valve. Take special care with the seals.
4. Remove the valve cover by loosening the screws with an Allen wrench. Take note of the orientation of the cap, as it is critical to replace it correctly during reassembly.
5. Install a new set of valves according to these assembly drawings. Ensure that the ball guides are assembled, and tighten the screws with a maximum torque (see torque table page 9).
6. Assemble the directional valve with being careful not to damage the O-rings and tighten the screws with a maximum torque of 132 lbf-in (15 N·m).

**Air sensor**

The air sensors are on the inside part of the diaphragm covers. To access them, follow the procedure for "Replacing diaphragms".

Once removed the covers following procedure:

1. Remove the side cover.
2. Remove the two screws that secure the air sensor to the top.
3. Remove all components of the sensor. Clean the area.
4. Introduce new components in the order shown.
5. Fit the remaining components in reverse order. Fit the side cover and tighten the screws.

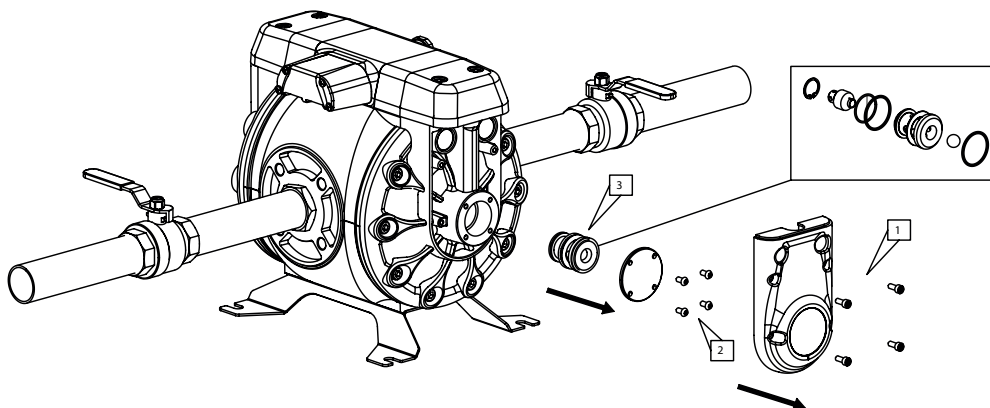

2015\_06\_09-11:40

For warranty information visit:  
Para información sobre garantía, visítenos:  
**[www.balcrank.com](http://www.balcrank.com)**

***Balcrank***

**Balcrank Corporation**  
Weaverville, NC 28787  
Tel.: 800-747-5300 · Fax: 800-763-0840

2015\_06\_09-11:40