



DEFENDER SERIES™

5 Gallon, Double Walled, Field Replaceable Spill Container

Model 705-550 Series

INSTALLATION, OPERATION, & MAINTENANCE



Manual #	Revision	Date	Changes from previous
F-9028	4	Dec.2010	Added self-tapping screw to parts list and drawings

Contents

Component and Subassembly Illustrations	3
Replacement Parts.....	3-4
Preparation	5
New Site/Retrofit Site/Electronic Sensor.....	5
Overview Diagram.....	6
Installation	7-8
Sensor/Non-Sensor/All Models	7
Integrity Testing	9
Vacuum Interstitial Testing Procedure.....	9
Spill Container Subassembly Replacement.....	10

Tools Required

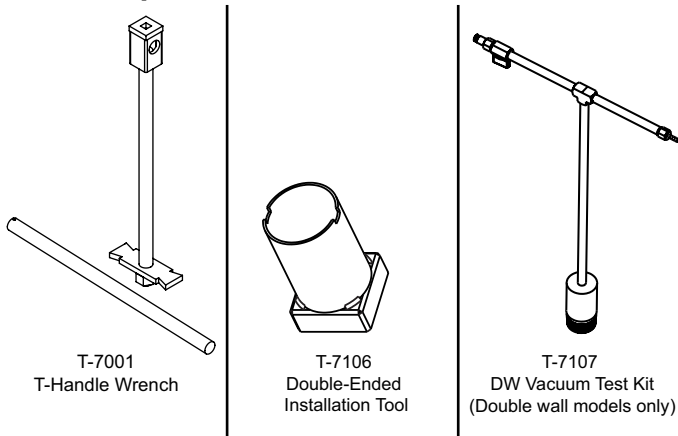



- 1/2" Socket or Nut Driver
- 1/2" Drive Torque Wrench
- Silicone based O-ring lubricant or silicone spray
- NON-HARDENING thread sealant approved for gasoline/oil service

Torque Specifications

Location	Ft-lbs (N-m)
Spill Container to UST Riser Pipe	125-150 (170-203)
Drop Tube (DT) Riser Clamp to Spill Container	75-100 (102-136)

Cautions / Warnings

Warning  Follow all federal, state and local laws governing the installation of this product and its associated systems. When no other regulations apply, follow NFPA codes 30, 30A and 70 from the National Fire Protection Association. Failure to follow these codes could result in severe injury, death, serious property damage and/or environmental contamination.

Warning  Always secure the work area from moving vehicles. To help eliminate unsafe conditions, secure the area by using a service truck to block access to the work environment, or by using any other reasonable means available to ensure the safety of service personnel. The Defender Series Spill Containment is used with tanks containing gasoline or other flammable substances.

Warning  Follow Petroleum Equipment Institute "Recommended Practices for Installation of Underground Liquid Storage Systems" (PEI/RP100). Failure to follow these practices could result in severe injury, death, serious property damage and/or environmental contamination.

Inspect the spill container assembly for damage before installation.

DO NOT disassemble the spill container subassembly. All the seals are factory tested to ensure the integrity of the containment space.

Make sure O-rings & seals are free of nicks, cuts, dirt, and debris before installation.

Make sure O-rings & seals are well lubricated with a silicone based lubricant.

Component and Subassembly Illustrations

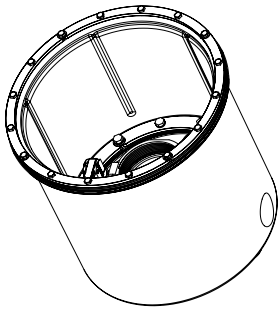

Figure 1: Double Wall Spill Container Subassembly
705551101/02

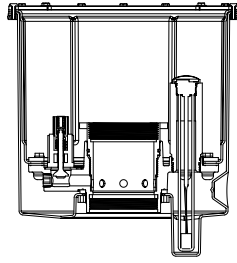

Figure 2: Double Wall Spill Container with Sensor Subassembly
705551201/02

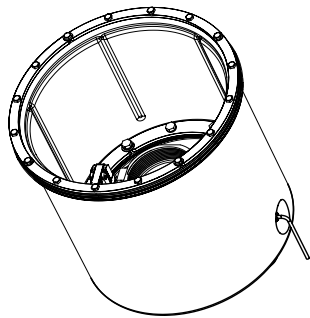

Figure 3: Gravel Guard and Concrete Ring

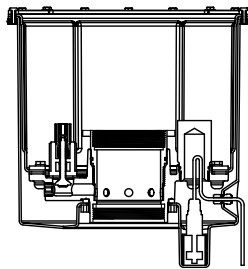

Figure 4: Snow Plow Ring

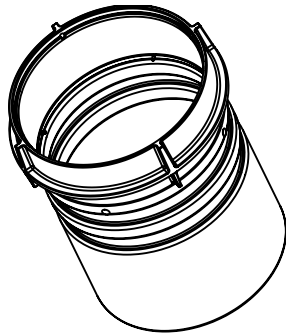

Figure 5: Drop Tube (DT) Riser Clamp Adapter

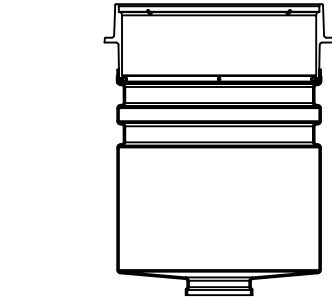

Figure 6: Inspection Port Pipe for P Monitor (Optional)

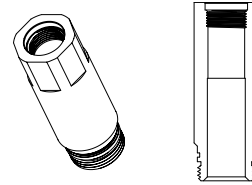

Figure 7: Inspection Port Pipe for Sensor (Optional)

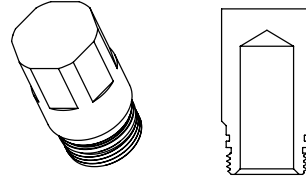
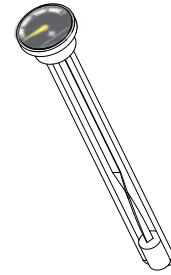

Figure 8: I² (Interstitial Integrity) Monitor (Optional)



Replacement Parts

Replacement Spill Container Subassemblies

Description	Part Number
Double Wall, w/o Riser, Cap and Adapter, with I ² monitor with Drain	705551101
Double Wall, w/o Riser, Cap and Adapter, with I ² Monitor, no Drain	705551102
Double Wall, w/o Riser, Cap and Adapter, with Sensor, with Drain	705551201
Double Wall, w/o Riser, Cap and Adapter, with Sensor, no Drain	705551202

Tools

T-Handle Wrench	T-7001
Double-Ended Installation Tool	T-7106
DW vacuum Test Kit (for double wall models only)	T-7107

Replacement Parts (continued)

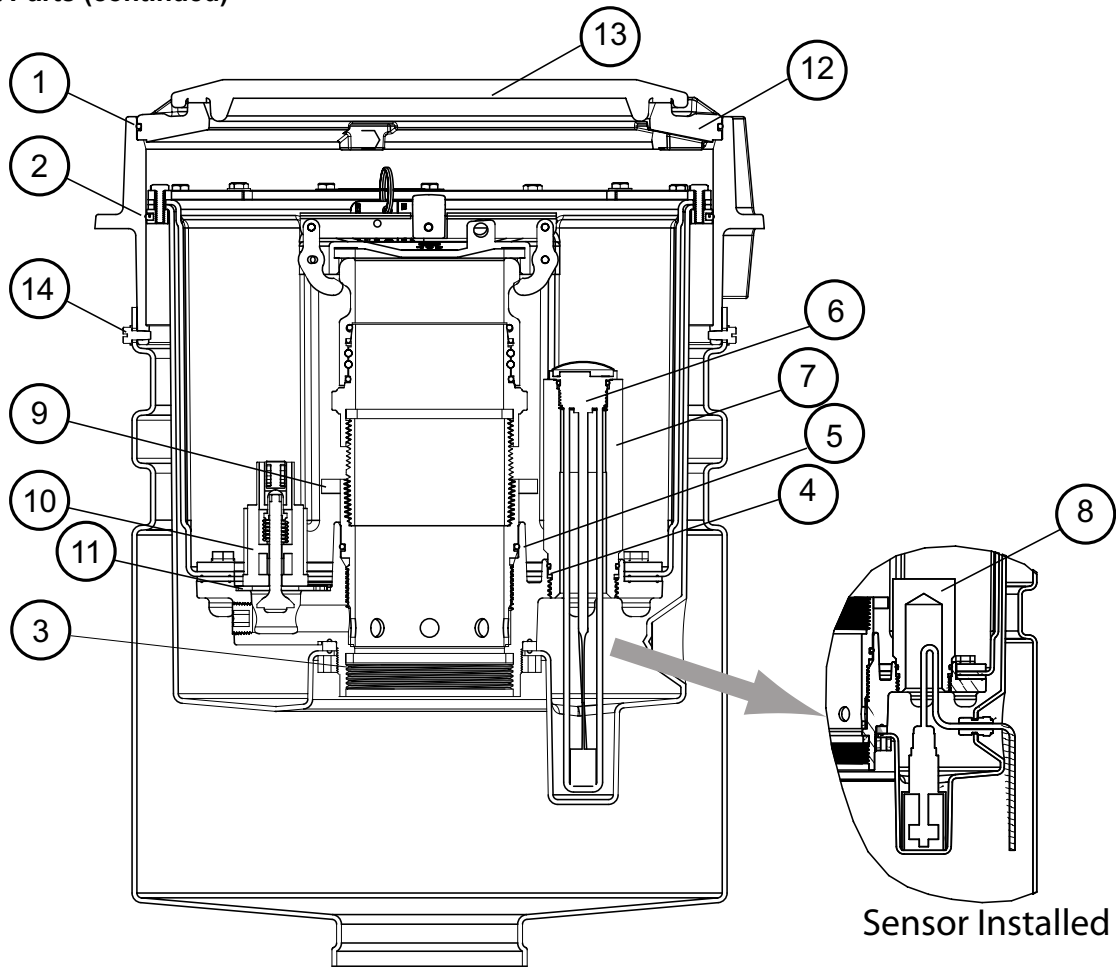

Figure 9: Defender Series™ Spill Container Spare Parts Location

Key	Description	Part Number
1	Snow Plow Ring O-ring	602009006
2	Spill container Seal-ring	70550301
3	Tank Riser Gasket	602256001
4	Inspection Port Pipe O-ring	400333132
5	DT Riser Clamp O-ring	1103939
6	I ² Monitor	70551101
7	Inspection Port (I ² Monitor)	70551002
8	Inspection Port (Sensor)	70551001
9	DT Riser Clamp	70550901EC
10	Pull to Push Drain Valve	70533701
11	Drain valve Gasket	70522601
12	Snow Plow Ring Assembly	70553001
13	Cover, Cast Iron w/gasket (gray)	70544001
	Cover, FRC (Specify color)	705420XX 705423XX
14	Slotted hex head self-tapping screw	1115601
*	Drain Chain and Clip	70553101

* Not shown

Preparation

New Site Application

1. Lay a string line or straight edge across the tank riser, at finished grade height.
2. Cut the riser pipe so that the top edge will be 15.0" (381 mm) +/- 1.5" (38.1 mm) from finished grade. The actual height (elevated grade) of the bucket will be 1.0" (25.4 mm) above finished grade, to ensure proper water runoff (sloped dome).

Note: Cut the riser pipe square/perpendicular to ensure a flat sealing surface.

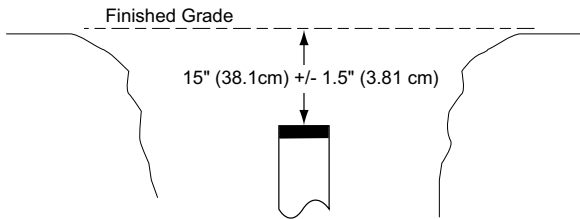

Figure 10: New Installation Riser Position

- If it is intended to use a M/F 4x4 adapter, take into account the height of the adapter [1.75" (45 mm) installed].
- The riser pipe must be between 13.5" (343 mm) and 16.5" (419 mm) from the finished grade level.

Retrofit Application

1. Remove an appropriate size section of concrete around the existing spill container. The minimum recommended size is a 36" (914 mm) square around each spill container.
2. Remove the existing spill container.
3. Excavate a 24" (610 mm) diameter by 24" (610 mm) deep (measured from top of riser) around the riser pipe.

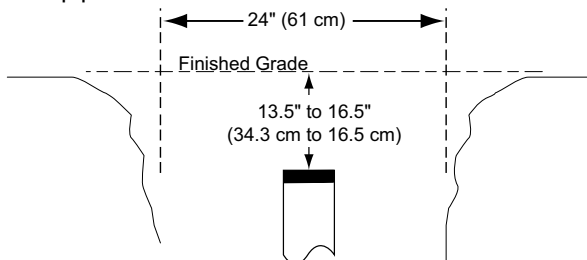

Figure 11: Retrofit Riser Position

4. Check the height of the riser pipe compared to finished grade level. Lay a straight edge across the excavated area and measure from grade to the top of the riser pipe. The riser pipe must be between 13.5" (343 mm) and 16.5" (419 mm).
5. Make sure the riser pipe was cut square/perpendicular to ensure a flat sealing surface.
 - If the pipe end is not cut square, an M/F 4x4 adapter may be used to provide an effective sealing surface as long as the length of riser pipe allows for it. The M/F 4x4 can also be used if the riser pipe is too short.
 - If the riser pipe is too long, it must be re-cut or replaced to obtain the appropriate length.

Electronic Sensor Preparation

1. Separate the spill container subassembly from the gravel guard/concrete ring subassembly.
 - a. Remove the snow plow ring.
 - Unthread the snow plow ring bolts using a 1/2" socket or nutdriver, until the heads of the bolts extend past the I.D. approximately 1/2" (13 mm).
 - Pull up on the snow plow ring firmly to break the seal between the O-ring and the concrete ring.
 - b. Remove the spill container subassembly.
 - Turn the unit upside-down so the concrete ring is on the ground.
 - Firmly push on the spill container subassembly to unseat the seal, and the bucket will come out of the concrete ring.
 2. Locate the gravel guard/concrete ring subassembly.
 3. Drill the appropriate sized hole for the conduit penetration supplied by the electrical contractor. It can be drilled in either the side or the bottom of the gravel guard. If drilled in the side, make sure to keep it as low as possible.
- Caution:** Make sure the spill container is not installed in the gravel guard/concrete ring as you risk puncturing the containment.
4. Install the conduit penetration fitting into the gravel guard.
 5. Measure at least 10 feet (3 meters) of cable from the end spill container cord grip & mark it with a marker or piece of tape. This will be the minimum amount of cable to be left loose inside the gravel guard to allow for installation & removal of the spill container. The rest of the length is available for connection into another sump or junction box.

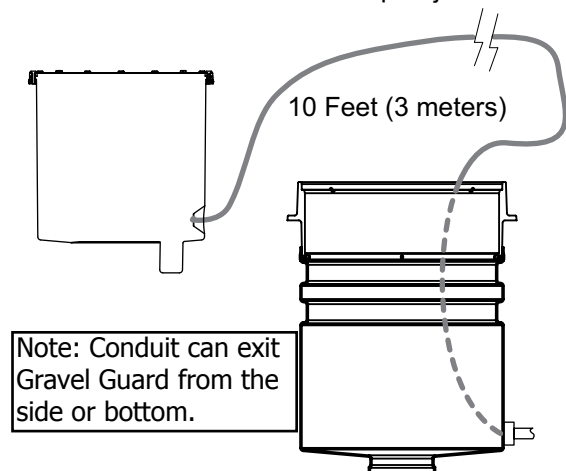

Figure 12: Cable Allowance

Caution: Do not loosen the cord grip on the spill container because it will compromise the seal integrity of the factory tested interstitial space.

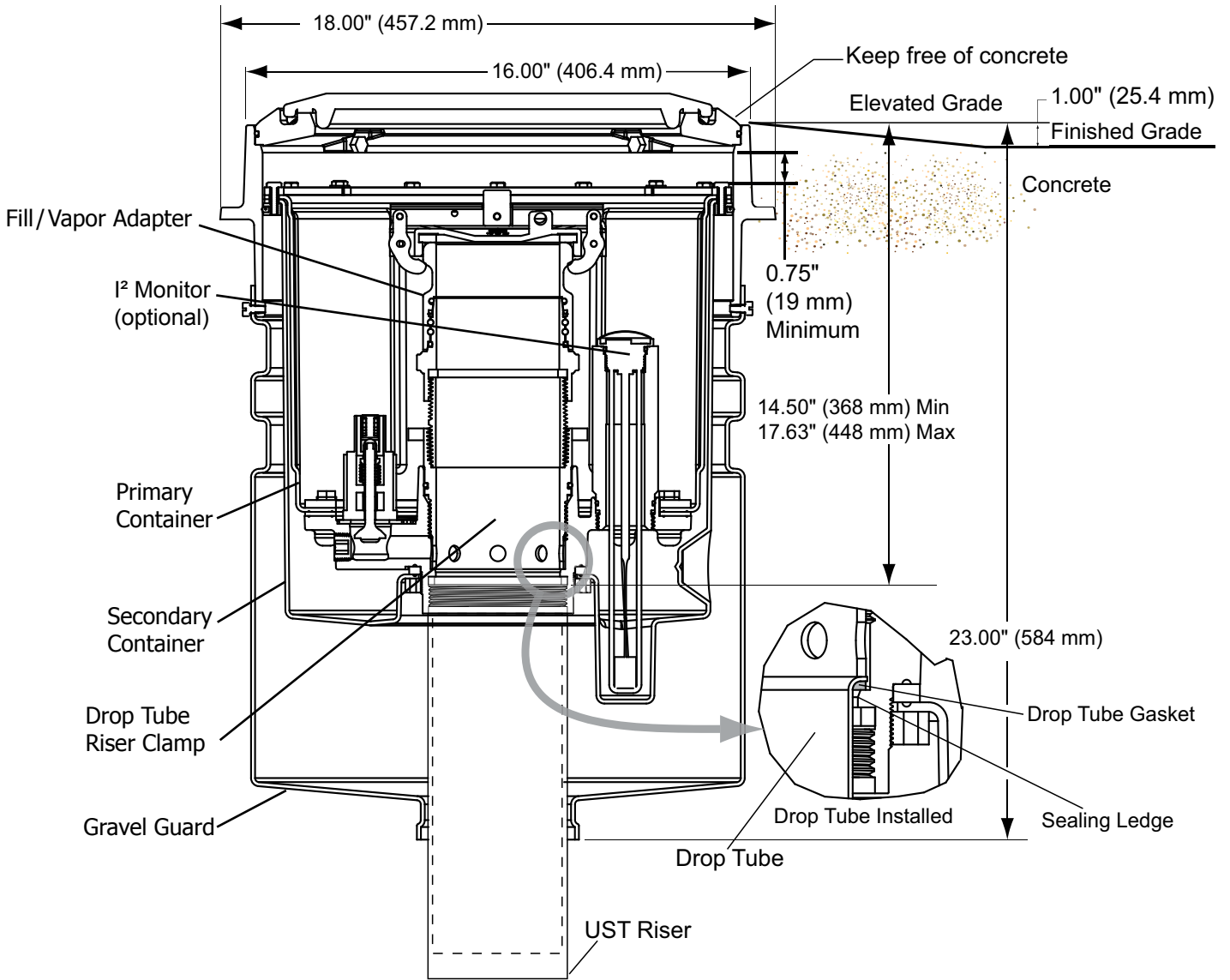

Figure 13: Defender Series™ Spill Container Overview

Installation

Electronic Sensor Model Only

1. Slide the gravel guard /concrete ring subassembly over the tank riser.
2. Locate the spill container subassembly and remove the DT (Drop Tube) Riser Clamp Adapter.
 - Use the round end of the T-7106 double ended tightening tool and the T-7001 T-Handle. The slots on the tool will engage with the lugs on the DT Riser Clamp Adapter.
3. Apply a NON-HARDENING thread sealant to the tank riser.
4. Feed the sensor cable through the conduit penetration as far as the 10 foot (3 meter) mark previously made in the preparation section.
5. Thread the spill container subassembly on to the tank riser using square end of the T-7106 double-ended installation tool and T-7001 T-Handle. Torque to 125-150 ft-lbs (170-203 N-m) using a 1/2" drive torque wrench.
6. Allow the sensor cord to loosely lay around the tank riser when the spill container is threaded on. This will facilitate the removal of the spill container in the future by allowing the cord to unwrap when unthreaded.

Note: If local codes or regulations require a tightness test using a leak detecting solution at the tank riser /spill bucket joint, do so now before raising the gravel guard and concrete ring subassembly.

7. Raise the gravel guard & concrete ring subassembly up around the spill container & pull firmly to seat the concrete ring ID onto the seal-ring.
 - Make sure the ID of the concrete ring is free of dirt and debris.
 - Make sure the seal-ring is free of nicks, cuts, dirt, and debris.
 - Make sure the seal-ring is lubricated with a silicone based lubricant.
8. Install the snow plow ring into the concrete ring.
 - Make sure the O-ring is free of nicks, cuts, dirt, and debris.
 - Make sure the O-ring is lubricated with a silicone based lubricant.
 - Align the (4) bolts to the ribs on the concrete ring.

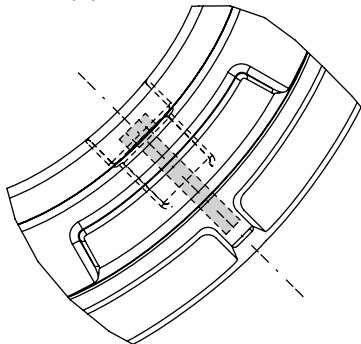

Figure 14: Snow Plow Ring Bolt Location

- Push down on the snow plow ring to seat the O-ring.
 - Using the 1/2" socket or nut driver, tighten the (4) bolts into the concrete ring (hand-tight).
9. Adjust the height of the top edge to the ELEVATED grade, which should be approximately 1" (25.4 mm) above finished grade level (1" (25.4 mm) of rain runoff dome).
 10. Install the conduit into the conduit penetration & feed the sensor wire through the conduit.

Non-Sensor Models

1. Remove the DT Riser Clamp Adapter from the Defender Series™ Spill container assembly.
2. Use the round end of the T-7106 double ended tightening tool and the T-7001 T-Handle. The slots on the tool will engage with the lugs on the DT Riser Clamp Adapter.
3. Apply a NON-HARDENING thread sealant to the tank riser.
4. Thread on the Defender Series™ Spill container assembly to the tank riser and tighten using square end of the T-7106 double-ended installation tool and the T-7001 T-Handle. Torque to 125-150 ft-lbs (170-203 N-m) using a 1/2" drive torque wrench.

Note: If local codes or regulations require a tightness test using a leak detecting solution at the tank riser /spill bucket joint:

- a. Make sure the snowplow ring is installed in the concrete ring before proceeding.
 - b. Remove the (4) slotted hex-head self-tapping screws from the gravel guard.
 - c. Slide the gravel guard down to access the joint between the tank riser and the spill bucket.
 - d. Perform a tightness test
 - e. Reinstall the gravel guard and attach it with the (4) self-tapping screws.
5. Adjust the height of the top edge to the ELEVATED grade, which should be approximately 1" (25.4 mm) above finished grade level (1" (25.4 mm) of rain runoff dome).

All Models

1. If needed, support the gravel guard / concrete ring with backfill.
 - If backfill is not available, temporarily support the concrete ring with 2x4s underneath the outer edge.
2. Install the drop tube through the spill container to allow the gasket to seat on the sealing ledge.
 - *Retrofit Installation Only* – Double check to see that the existing drop tube is cut to the appropriate length.
3. If the unit was ordered with the riser, cap, and fill/vapor adapter – they should all be pre-assembled to the DT Riser Clamp Adapter – SKIP TO STEP 5.

4. Assemble the DT Riser Clamp Adapter to the pipe nipple and fill/vapor adapter.
 - Use only the flats on the top of the DT Riser Clamp Adapter for tightening.
 - Cut & thread the DT Riser Pipe. The overall length of the DT Riser Clamp Adapter assembly including the adapter and dust cap should be no more than 12.5" (317.5 mm).

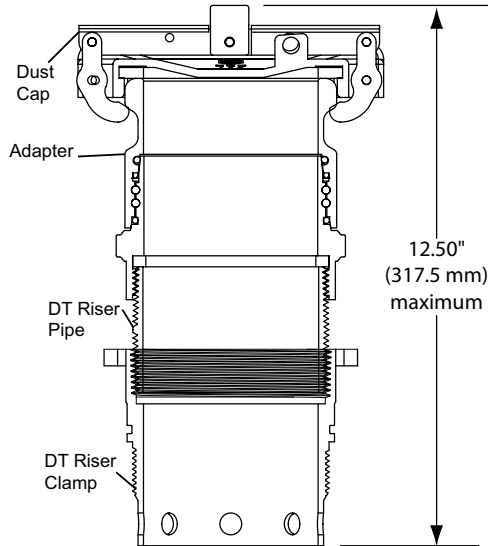

Figure 15: Drop Tube (DT) Riser Clamp Assembly Dimensions

- Use a thread sealant between the pipe nipple & the DT Riser Clamp.
 - Torque to the manufacturer's recommended value using the correct tools.
5. Install the DT Riser Clamp Adapter into the spill container using the round end of the T-7106 double ended tightening tool and T-7001 T-Handle. Torque to 75-100 ft-lbs (101.7 N-m - 135.6 N-m). The slots on the tool will engage with the lugs on the DT riser clamp adapter.
 6. Install fill/vapor dust cap.

Note: Verify that when the dust cap is installed, it does not interfere with the underside of the spill container lid.

7. Double-check & verify the gravel guard/concrete ring assembly is still at ELEVATED grade height, adjust if necessary.
8. Perform the integrity testing AFTER BACKFILL but BEFORE CONCRETE.
 - See Integrity Testing on Page 9
9. Install spill container cover/lid.

10. Pour concrete around the Defender Series™ spill container, making sure to dome the concrete at least 1" (2.54 cm) to allow for adequate runoff. The sloping of the concrete should begin at the outer edge of the concrete ring tabs (Figure 18). Keep the snow plow ring and cover clean and free of any concrete splatter (the snow plow ring must be able to be removed if service is needed).

11. If equipped with a drain, adjust the position of the lower key ring on the chain so that the drain is held open when clipped up on the ledge of the snow plow ring.
12. Attach the upper most key ring to the fill/vapor dust cap.

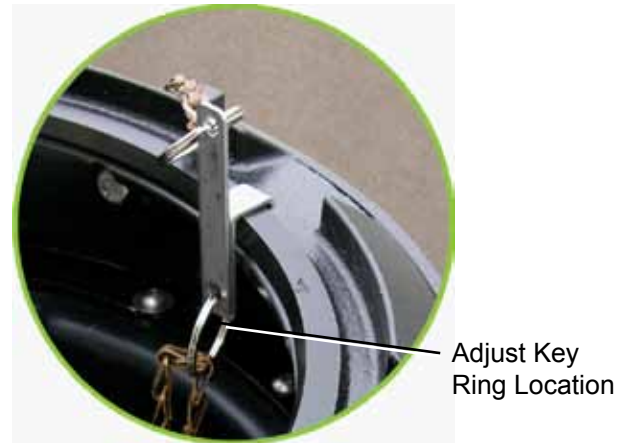

Figure 16: Drain Chain and Clip Shown installed, holding drain open

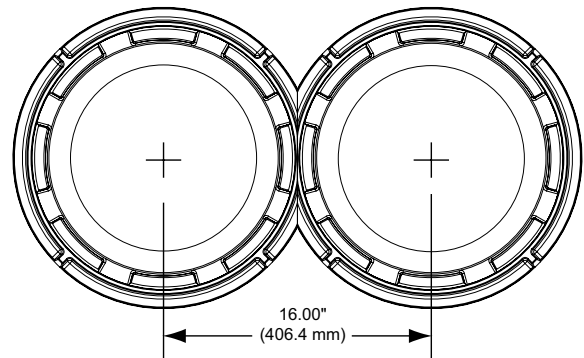

Figure 17: 16" On-Center Mounting (Top View)

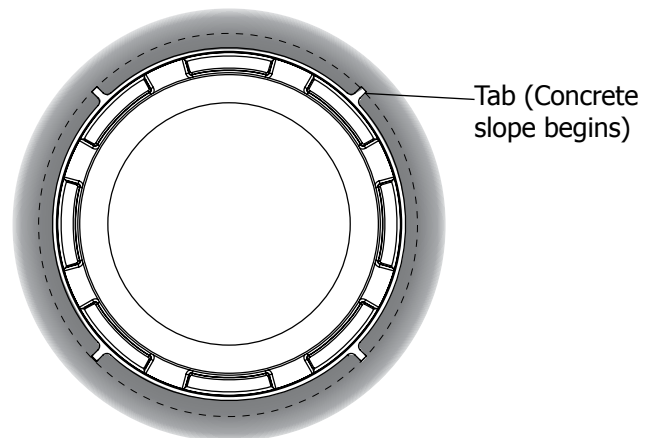

Figure 18: Concrete Placement

Integrity Testing

All Defender spill buckets are integrity tested at the factory. We recommend that the containment integrity be re-confirmed. Always test per local codes. If local codes do not specify a procedure, or refers to the manufacturer's testing, use the testing as below.

Double Wall: Perform Hydrostatic Testing Procedure and the Vacuum Interstitial Testing Procedure.

Hydrostatic Testing Procedure

1. Fill the spill bucket with water until the level is just below the upper lip of the snow plow ring.
2. After 1 hour, if there is no detectable drop in water level, the spill bucket has passed the test.

Vacuum Interstitial Testing Procedure

1. Remove the Inspection Port Pipe from the spill container.
2. Install the T-7107 DW Vacuum Test Kit into the inspection port (hand tight).
 - Make sure the O-ring is properly lubricated, clean of dirt and debris, and the I.D. sealing surface of the inspection port is clean of dirt and debris.
 - If the unit includes a sensor, it does not need to be removed.

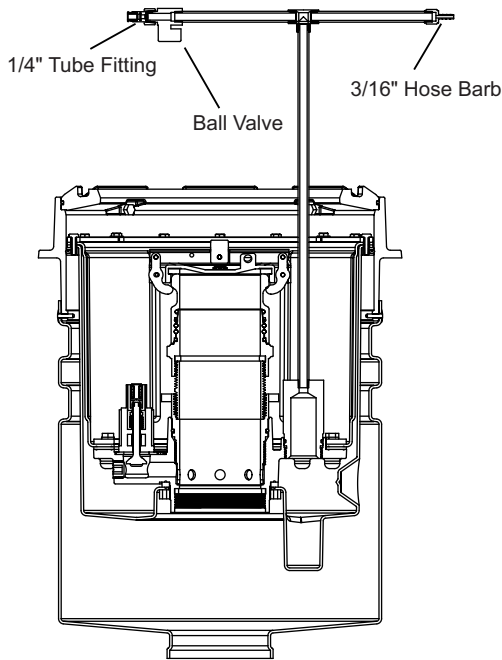

Figure 19: Tool T-7001 Installed

3. Connect the vacuum source to the 1/4" tube fitting (Push-Lok/ Push-to-connect).
4. Connect the manometer to the 3/16" hose barb.
5. Close the ball valve.
6. Apply vacuum source (using a pump or generator) and SLOWLY open the ball valve until the manometer reads 30 inches of water column (WC) (7.472 kPa), then close the ball valve.
7. Wait approximately 1 minute to allow the interstitial space to stabilize.
8. If needed, re-apply the vacuum source to obtain 30" WC (7.472 kPa).
9. Allow spill container to rest undisturbed for 5 minutes while under vacuum.
10. Check the manometer reading after 5 minutes. If it reads above 26" WC (6.476 kPa), the interstitial space has passed the test.
11. If the manometer reads less than 26" WC (6.476 kPa), check all the connections and repeat the test. Otherwise contact FFS Technical Service.

Integrity Testing Recommendations

Test upon installation and thereafter per local codes. Otherwise, test every 3 years

Recommended Maintenance & Inspection Procedures

Monthly

1. Clean any sand, gravel, or dirt from the snow plow ring. Buildup of material will prevent the manhole lid from sitting flat and diverting rain water. In addition to water infiltration, this can lead to premature lid failures and tripping hazards.
2. Inspect the cover gasket and replace it if necessary.
3. Inspect the spill container for the presence of liquid. If any is present, identify the material (water or fuel) and dispose of it using your preferred acceptable method (pump it out or drain it into the tank).
4. Inspect the primary spill container and the drain valve screen for any foreign material collecting in the bottom of the tank. Remove any large objects (leaves, rags, etc.) and wipe the bottom of the tank with a disposable rag.
5. Inspect the entire spill container for obvious damage. Verify that all components are functioning properly.
6. Inspect the Interstitial space for the presence of liquid.
 - If it is installed with the I² monitor, check the yellow indicator position. If the yellow indicator is positioned below the white area on the gauge face, liquid is not detected
 - If it is installed with the TSP-ULS electronic sensor, check the tank gauge equipment located inside the station. Confirm the sensor status is normal and does not show an alarm condition.
 - If liquid is detected by either monitoring method, identify and properly dispose of the liquid. Confirm the status of the interstitial space by performing the Vacuum Interstitial Integrity Procedure.

Yearly

1. Inspect the interstitial monitoring equipment.
 - If it is installed with the I² monitor, test the operation of the float/Indicator mechanism. Remove the I² monitor/port pipe assembly by unscrewing it from the tank adapter. Manually move the float up and down and verify that the float moves freely and the indicator arrow rotates.
 - If it is installed with the TSP-ULS electronic sensor, check to see that it is functioning properly. Remove the inspection port pipe from the tank adapter to gain access to the sensor. Remove the sensor from the interstitial space and turn it upside down to raise the float. Verify with the tank gauge in the station that a sensor alarm occurred. If it did, the sensor is operating properly. Reinstall the sensor and the inspection port pipe.
2. Record inspection results per local codes.

Spill Container Subassembly Replacement

Removal

1. Remove cover.
2. Remove the snow plow ring.
 - Unthread the snow plow ring bolts using a 1/2" (13 mm) socket or nut-driver, until the heads of the bolts extend past the I.D. approximately 1/2" (13mm).
 - Pull up on the snow plow ring firmly to break the seal between the O-ring and the concrete ring.
3. Remove the dust cap.
4. Using the round end of the T-7106 double-ended installation tool and T-7001 T-Handle, remove the DT riser clamp adapter.
5. Remove the drop tube assembly.
6. Using the square end of the T-7106 double-ended installation tool and the T-7001 T-Handle, unthread the spill container assembly.
7. Pull up firmly and evenly on the spill container to remove the spill container from the concrete ring/gravel guard.

Installation

1. Clean the I.D. of the concrete ring (sealing surface) thoroughly and re-lubricate with a silicone based O-ring lubricant or spray.
2. Apply a NON-HARDENING thread sealant to the tank riser.
3. Lubricate the seal on the outside of the spill container with a silicone based O-ring lubricant or spray.
4. Evenly push down on the spill container subassembly to seat the seal-ring, & slide it down to where the bucket meets the tank riser.
5. Thread on the spill container subassembly to the tank riser using square end of the T-7106 double-ended installation tool and The T-7001 T-Handle. Torque to 125-150 ft-lbs (169.5 - 203.4 N-m) using a 1/2" (13 mm) drive torque wrench.
6. Re-install the drop tube assembly.
 - Check the drop tube gasket and replace if necessary.
7. Re-install the DT Riser Clamp Adapter into the spill container using the round end of the T-7106 double ended tightening tool and T-7001 T-Handle. The slots on the tool will engage with the lugs on the DT riser clamp adapter. Torque to 75-100 ft-lbs (102-136 N-m).
8. Re-install the snow plow ring into the concrete ring.
 - Replace and lubricate the O-ring.
 - Align the (4) bolts to the ribs on the concrete ring.
 - Push down on the snow plow ring to seat the O-ring.
 - Using the 1/2" (13 mm) socket or nut driver, tighten the (4) bolts into the concrete ring (hand tight).
9. Re-install the dust cap.
10. Re-install the cover.



Franklin Fueling Systems

3760 Marsh Road
Madison, WI 53718, U.S.A.

Tel: +1 608 838 8786

Tel: USA & Canada 1 800 225 9787

Tel: Mexico 001 800 738 7610

www.franklinfueling.com