

# Balcrank

## Lynx Series Pumps

### Lynx Piston Pumps

*Innovation*

*Performance*

*Simplicity*



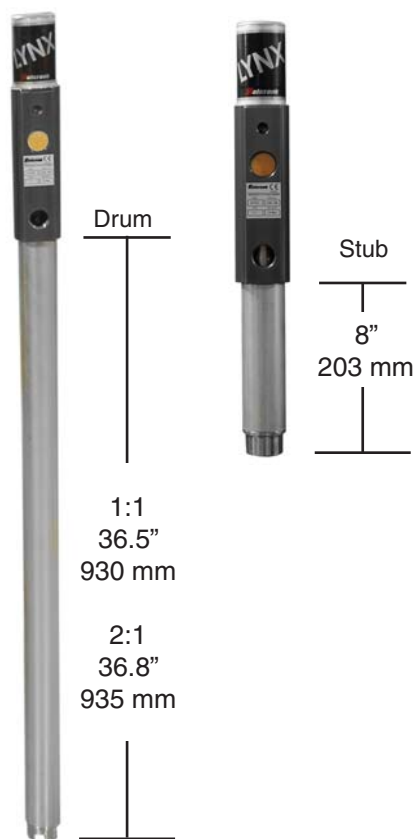

The Lynx 1:1 and 2:1 double action pumps are engineered for outstanding performance and reliability to transfer fluid from pails, drums, tanks, and totes. The Lynx pump provides fast delivery of cutting, synthetic, hydraulic, and mineral-based lubricants.

The Lynx 2:1 multi-fluid pump is designed to provide the capabilities and versatility needed to transfer fluids to the point of application. Example of fluids: Detergents, cleaning fluids, synthetic hydraulic oil, antifreeze, windshield fluids, solvents, sealants or other corrosive fluids, etc, compatible with AISI 316, PTFE and Viton.

NOTE: Warning! Do not use any Lynx series products with flammable fluids.

- Double acting pump – Pumping product on both the up and down stroke providing smooth and reliable flow and pressure.
- Patented air valve – designed to operate with lower air consumption.
- Air valve design has fewer components - for reliable operation; easy and economical maintenance.
- Factory lubricated air motor – no need for air lubricator.
- Built in sintered brass air filter – assures clean & quiet operation.
- Anodized aluminum air piston – corrosion resistant, less sensitive to moisture in air system.
- Height adjustable 2" bung adapter – to fit all types of drums, drum covers, tanks, etc.
- Pump inlet easily accepts a variety of extensions – to fit all types and sizes of tanks and containers.

## Available Models

### Lynx 1:1 & 2:1 Pump

1110-010	1:1 Bare Stub pump with Bung Adapter
1110-009	1:1 Bare Drum pump with Bung Adapter
1160-009	2:1 Bare Stainless steel drum pump with bung adapter

## Applications

- 1:1** - Transfer fluids; Petroleum based oils and synthetic oils
- 2:1** - Automotive dealerships, Transmission centers, Tire centers, Quick lubes, Industrial plants, Mobile lube, and Mining. Anti-freeze and windshield fluids.

## Pump Specifications

### Lynx 1:1 Pump

Air inlet	1/4" NPT (F)
Fluid inlet (stub only)	1" NPT (F)
Fluid outlet	3/4" NPT (F)
Max. Free Flow	10.6 GPM on 150 PSI air pressure
Operating Air Pressure Range	45 - 150 psi
Wetted Materials	Carbon steel, Buna-N™, aluminum, brass, and polyurethane

### Lynx 2:1 Pump

Air inlet	1/4" NPT (F)
Fluid inlet	N/A
Fluid outlet	3/4" NPT (M)
Max. Free Flow	8.2 GPM on 150 PSI air pressure
Operating Air Pressure	45 - 150 psi
Wetted Materials	Stainless steel, Viton, and PTFE



**Pump & Hose Package - Stub**  
1111-010

**Package Includes:**

Bare Pump:	1110-010
Bung Adapter	4411-021
Air Hose (5' x 3/8")	8132-005
Fluid Hose (5' x 3/4")	8261-005



**Pump & Spigot Package - Drum**  
1111-009  
**Pump & Spigot Package - Stub**  
1111-025

**Package Includes:**

Bare Pump Drum or	1110-009
Bare Pump Stub:	1110-010
Bung Adapter	4411-021
Spigot	4200-013



**1:1 Pump & Hose Package Drum**  
1111-011  
**2:1 SS Pump & Hose Package Drum**  
1161-003

**Package Includes:**

Bare 1:1 Pump: or	1110-009
Bare 2:1 SS Pump:	1160-009
Bung Adapter	4411-021
Air Hose (5' x 3/8")	8132-005
Fluid Hose (5' x 3/4")	8261-005



**16 Gal. Drum Package - Dolly**  
1111-013

**Package Includes:**

Bare Pump:	1110-010
Bung Adapter	4411-021
Filter Regulator (1/4")	3260-033
Fluid Hose (10' x 1/2")	8263-010
High Flow Handle	3320-019
Suction Tube or Kit	832967
Dolly	4310-003

\* Drum Not Included



**55 Gal. Drum Package - Dolly**  
1111-012

**Package Includes:**

Bare Pump:	1110-009
Bung Adapter	4411-021
Filter Regulator (1/4")	3260-033
Fluid Hose (10' x 1/2")	8263-010
High Flow Handle	3320-019
Dolly	4310-004

\* Drum Not Included



**55 Gal. Drum Package - Cart**  
1111-014

**Package Includes:**

Bare Pump:	1110-009
Bung Adapter	4411-021
Filter Regulator (1/4")	3260-033
Fluid Hose (10' x 1/2")	8263-010
High Flow Handle	3320-019
Cart	4320-008

\* Drum Not Included



The Lynx 3:1 ratio double action pump is engineered for outstanding performance and reliability to dispense lubricating oils and similar products up to SAE 90 in piped systems.

NOTE: Warning! Do not use any Lynx series products with flammable fluids.

- Double acting pump – Pumps product on both the up and down stroke providing smooth and reliable flow and pressure.
- Patented air valve – designed to operate with low air consumption and moist air.
- Air valve design has fewer components - for reliable operation; easy and economical maintenance.
- Factory lubricated air motor - no need for air lubricator.
- Built in sintered brass air filter – assures clean & quiet operation.
- Anodized aluminum air piston – corrosion resistant, less sensitive to moisture in air system.
- Height adjustable 2" bung adapter – to fit all types of drums, drum covers, tanks, etc.
- Pump inlet easily accepts a variety of extensions - to fit all types and sizes of tanks and containers.

### Available Models

1110-007	3:1 Bare Stub pump with Bung Adapter
----------	--------------------------------------

### Applications

**3:1** - Automotive dealerships, Transmission centers, Tire centers, Quick lubes, Industrial plants, Mobile lube, and Mining. Petroleum based oils and synthetic oils

### Pump Specifications

Air inlet	1/4" NPT (F)
Fluid inlet	3/4" NPT (F)
Fluid outlet port	3/4" NPT (F)
Max. Free Flow	6.6 GPM on 150 PSI air pressure
Operating Air Pressure Range	45 - 150 psi
Wetted Materials	Carbon steel, Buna-N™, aluminum, brass, and polyurethane



**Pump & Hose Package - Stub**  
1111-015

**Package Includes:**

- Bare Pump: 1110-007
- Bung Adapter 4411-022
- Air Hose (5' x 3/8") 8132-005
- Fluid Hose (5' x 3/4") 8261-005



**Pump & Wall Mount Package - Stub**  
1111-016

**Package Includes:**

- Bare Pump: 1110-007
- Bung Adapter 4411-022
- Air Hose (5' x 3/8") 8132-005
- Fluid Hose (5' x 3/4") 8261-005
- Wall Mount Bracket 4411-008
- Suction Side Bung adapter 4411-011

\* Drum Not Included



**16 Gal. Drum Package Dolly**  
1111-005  
**16 Gal. Drum Package Cart**  
1111-006

**Package Includes:**

- Bare Pump: 1110-007
- Bung Adapter 4411-022
- Filter Regulator (1/4") 3260-033
- Fluid Hose (10' x 1/2") 8249-010
- Analog Control Handle 3330-146
- Suction Tube or Kit 832884
- Dolly or Cart 4310-003 / 4320-009

\* Drum Not Included



**55 Gal. Drum Package Dolly**  
1111-007  
**55 Gal. Drum Package Cart**  
1111-008

**Package Includes:**

- Bare Pump: 1110-007
- Bung Adapter 4411-022
- Filter Regulator (1/4") 3260-033
- Fluid Hose (10' x 1/2") 8249-010
- Analog Control Handle 3330-146
- Suction Tube or Kit 832916
- Dolly or Cart 4310-004 / 4320-008

\* Drum Not Included



**24 Gallon Package**  
1111-021

**Package Includes:**

- Bare Pump: 1110-007
- Bung Adapter 4411-022
- Filter Regulator (1/4") 8249-010
- Analog Control Handle 3330-146
- Suction Tube or Kit 832959

\* Hose Reel Optional



The Lynx 5:1 ratio double action pump is engineered for outstanding performance and reliability. The Lynx 5:1 pump is designed to dispense lubricating oils and similar products up to SAE 140 in piped systems and is capable of dispensing up to 3 outlets simultaneously.

- Double acting pump – oil output from pump shall be equal on both up and down stroke.
- Patented air valve – designed to operate with low air consumption and moist air.
- Air valve design has fewer components - for reliable operation; easy and economical maintenance.
- Factory lubricated air motor - no need for air lubricator.
- Built in sintered brass air filter – assures clean & quiet operation.
- Anodized aluminum air piston – corrosion resistant, less sensitive to moisture in air system.
- Height adjustable 2” bung adapter – to fit all types of drums, drum covers, tanks, etc.
- Pump inlet easily accepts a variety of extensions - to fit all types and sizes of tanks and containers.

**Available Models**

1110-011	5:1 Bare Stub pump with Bung Adapter
----------	--------------------------------------

**Applications**

5:1 - Automotive dealerships, Transmission centers, Tire centers, Quick lubes, Industrial plants, Mobile lube, and Mining; Petroleum based oils and synthetic oils

**Pump Specifications**

Air inlet	1/4" NPT (F)
Fluid inlet	3/4" NPT (F)
Fluid outlet port	3/4" NPT (F)
Max. Free Flow	5.3 GPM on 150 PSI air pressure
Operating Air Pressure Range	45 - 150 psi
Wetted Materials	Carbon steel, Buna-N™, aluminum, brass, and polyurethane



**Pump & Hose Package - Stub**  
1111-017

**Package Includes:**

- Bare Pump: 1110-011
- Bung Adapter 4411-022
- Air Hose (5' x 3/8") 8132-005
- Fluid Hose (5' x 3/4") 8261-005



**Pump & Wall Mount Package - Stub**  
1111-018

**Package Includes:**

- Bare Pump: 1110-011
- Bung Adapter 4411-022
- Air Hose (5' x 3/8") 8132-005
- Fluid Hose (5' x 3/4") 8261-005
- Wall Mount Bracket 4411-008
- Suction Side Bung adapter 4411-011



\* Drum Not Included



**16 Gal. Drum Package Dolly**  
1111-019  
**16 Gal. Drum Package Cart**  
1111-022

**Package Includes:**

- Bare Pump: 1110-011
- Bung Adapter 4411-022
- Filter Regulator (1/4") 3260-033
- Fluid Hose (10'x 1/2") 8249-010
- Analog Control Handle 3330-146
- Suction Tube or Kit 832884
- Dolly or Cart 4310-003 / 4320-009

\* Drum Not Included



**55 Gal. Drum Package Dolly**  
1111-020  
**55 Gal. Drum Package Cart**  
1111-023

**Package Includes:**

- Bare Pump: 1110-011
- Bung Adapter 4411-022
- Filter Regulator (1/4") 3260-033
- Fluid Hose (10'x 1/2") 8249-010
- Analog Control Handle 3330-146
- Suction Tube or Kit 832916
- Dolly or Cart 4310-004 / 4320-008

\* Drum Not Included



**24 Gallon Package**  
1111-024

**Package Includes:**

- Bare Pump: 1110-011
- Bung Adapter 4411-022
- Filter Regulator (1/4") 3260-033
- Fluid Hose (10'x 1/2") 8249-010
- Analog Control Handle 3330-146
- Suction Tube or Kit 832959

\* Hose Reel Optional



Ideal for use with grease up to NLGI #2.

### Portable high-pressure packages.

- **In-line Balanced Design** - This design provides even distribution on each stroke allowing for long seal life.
- **Double Acting Pump Design** - Pumps product on both the up and down stroke providing smooth and reliable flow and pressure.
- **Positive Pump Priming** - An effective priming piston provides positive pump priming, even when used with high viscosity or tacky greases. A hardened foot valve minimizes pump damage due to contaminants. Corrosion proof air motor design tolerates moisture in compressed air.
- **On-Demand Operation** - Pump adjusts speed to match system flow and pressure requirements. When the dispense valve is closed: the pump stops. Pump can be left in the stalled condition without damaging the pump or consuming compressed air.
- **One Piece Molded Air Piston** - All air connections are integrated in the air motor cylinder mold.

### Improved Valves

- **Air Valve Mechanism** - One toggle driven air valve mechanism for fast and accurate reversing action. Precision-machined parts provide high reliability.
- **Upper Ball Check** - Precision machined and hardened upper ball check to tolerate small impurities in the grease.
- **Foot Valve** - Hardened foot valve for maximum reliability. Internal step seal for increased efficiency. Internal filter mesh for reliable pump operation.

### Available Models

1151-027	Lynx 55:1 Grease 25-35 lb. Portable Package
1151-028	Lynx 55:1 Grease 120 lb. Portable Package

### Applications

High pressure, low volume portable grease dispensing for automotive and general industry use. Not recommended for piped overhead systems. Ideal for use with grease up to NLGI #2.

### Pump Specifications

Air Motor Diameter	2.75" (70 mm)
Air inlet	1/4" NPT (F)
Fluid inlet	N/A
Fluid outlet port	1/4" NPT (F)
Max. Free Flow	1.2 lb./min (540 gr/min) @ 100 PSI air pressure, NLGI 1-2 grease
Operating Air Pressure Range	40 - 140 psi
Noise Level	92 dB
Wetted Materials	Steel, Zinc, NBR, PTFE, Aluminum





**Portable Pump Packages - 25-35 lb.**  
1151-027

**Packages Includes:**

- Bare Pump: 832983
- Bung Adapter 4411-023
- Filter Regulator (1/4") 3260-033
- Fluid Hose (10' x 3/8") 8332-010
- HD Grease Handle 3310-026
- Drum Cover 4420-010
- Follower Plate 4440-013



**Portable Pump Packages - 120 lb.**  
1151-028

**Packages Includes:**

- Bare Pump: 832984
- Bung Adapter 4411-023
- Filter Regulator (1/4") 3260-033
- Fluid Hose (10' x 3/8") 8332-010
- HD Grease Handle 3310-026
- Drum Cover 4420-011
- Follower Plate 4440-014
- Dolly 4310-003



Dolly		
4310-003	120 lb. Wide Track Band Dolly	
Drum covers		
4420-010	25-35 lb.	
4420-011	120 lb.	
Follower Plate		
4440-013	25-35 lb.	
4440-014	120 lb.	
Grease Handles		
3310-007	Pro Series Booster	
3310-009	Pro Series Booster w/ swivel	
3310-026	Heavy Duty Non-Boosting	
3310-027	Heavy Duty Non-Boosting w/18" whip hose	
3310-028	Heavy Duty Non-Boosting w/36" whip hose	
Grease Handle Accessories		
5310-020	Grease Coupler/Nozzle	
8390-002	18" Flexible Extension	
8390-003	36" Flexible Extension	
5310-018	Z-Swivel 1/4" NPT (F) x 1/4" NPT (M)	
4420-012	Grease Gun Holder	



**UL 142 Tanks**

**(Single and Double Wall)\* Includes:**

- 50' x 1/2" Hose Reel
  - Mechanical Meter with flex extension
  - Lynx 3:1 Pump
  - Filter Regulator
  - Tank has 2" lockable fill cap and gauge
  - Tailgate delivery and advance notification available
  - Assembly required for 330 gal packages: equipment ships separately.
- All other packages come fully assembled with everything you need for immediate use.

\* Check local codes for venting and installation equipment



Workbench style tanks are the best choice when work space is at a premium. The flat top and 30-33" height make workbench style tanks the perfect choice for crowded shops needing additional workspace.

Workbench Tank Package			
Size		Wall Construction	Model Number
165 Gal.	33H x 33W x 36L	Single Wall	1134-003
165 Gal.	33H x 33W x 36L	Double Wall	1134-004
250 Gal.	30H x 32W x 60L	Single Wall	1134-007
250 Gal.	30H x 32W x 60L	Double Wall	1134-008
280 Gal.	33H x 33W x 60L	Single Wall	1134-015
280 Gal.	33H x 33W x 60L	Double Wall	1134-016



Choose vertical Obround tanks when floor space is limited, Vertical Obround tanks have the smallest footprint per gallon of oil.

**Vertical Obround Package**

Size	Wall Construction	Model Number
275 Gal. 60H x 44W x 27D	Single Wall	1134-019
275 Gal. 60H x 44W x 27D	Double Wall	1134-020
330 Gal. 72H x 44W x 27D	Single Wall	1134-027
330 Gal. 72H x 44W x 27D	Double Wall	1134-028



Horizontal Obround tanks combine the small foot print of a vertical tank with the easy access of a work bench tank. The fill cap and hose reel are located a convenient 44" from the floor.

**Horizontal Obround Package**

Size	Wall Construction	Model Number
275 Gal. 44H x 27W x 60L	Single Wall	1134-011
275 Gal. 44H x 27W x 60L	Double Wall	1134-012
330 Gal. 44H x 27W x 72L	Single Wall	1134-023
330 Gal. 44H x 27W x 72L	Double Wall	1134-024

## **Customer Support**

**800-747-5300 or 828-645-4261**  
**(Mon. - Fri., 8 am - 5 pm ET)**

- Order entry
- Product availability
- Pricing
- Basic product information
- Shipping dates and delivery information
- Product return authorization

## **Order by fax**

**800-763-0840 or 828-658-0840**

- Fax orders day or night
- Free-up phone lines
- Order confirmed next business day by fax or e-mail

## **Technical Support**

**800-747-5300 or 828-645-4261**  
**(Mon. - Fri., 8 am - 5 pm ET)**

- Repair Advice
- Product application recommendations
- Warranty claims and returns
- Service bulletins

## **E-mail Ordering & Online Support**

Website: [www.balcrank.com](http://www.balcrank.com)  
E-mail: [info@balcrank.com](mailto:info@balcrank.com)  
E-mail Ordering: [orders@balcrank.com](mailto:orders@balcrank.com)

## **Service Bulletins**

- [http://www.balcrank.com/service/service\\_bulletins.com](http://www.balcrank.com/service/service_bulletins.com)

