

ACEU

Diesel Engine Driven



Self Priming Centrifugal Pump

Models 16C2-4045D and 16C20-4045D

Size 6" x 6"



70 MT

Total Head		Capacity of Pump in U.S. Gallons per Minute (GPM) at Continuous Performance				
P.S.I.	Feet					
63.7	147	420	420	420	420	420
54.2	125	615	870	940	940	940
43.4	100	660	950	1170	1340	1340
32.5	75	680	960	1195	1420	1510
21.7	50	695	960	1200	1450	1560
Suction Lift		25'	20'	15'	10'	5'

PUMP SPECIFICATIONS

Size: 6" x 6" (152 mm x 152 mm) NPT - Female.
Casing: Gray Iron 30.
Maximum Operating Pressure 107 psi (738 kPa).
Semi-Open, Two Vane Impeller: Ductile Iron 65-45-12. Handles 3" (76,2 mm) Diameter Spherical Solids.
Impeller Shaft: Stainless Steel 17-4.
Replaceable Wear Plate: Carbon Steel C1015.
Removable Cover Plate: Gray Iron 30; 36 lbs. (16 kg).
Intermediate: Gray Iron 30.
Seal Plate: Gray Iron 30.
Seal Model 16C2-4045D: Double, Grease-Lubricated with Spring Loaded Grease Cup. Sintered Bronze Stationary Seal Seats. Steel Rotating Faces. Neoprene Packing Rings. Maximum Temperature of Liquid Pumped, 110°F (43°C). Maximum Suction Pressure 10 psi (69 kPa).
Seal Model 16C20-4045D: Type 2, Mechanical, Oil-Lubricated, Floating, Self-Aligning. Tungsten Titanium Carbide Rotating and Stationary Faces. Stainless Steel 316 Stationary Seat. Fluorocarbon Elastomers (DuPont Viton® or Equivalent). Stainless Steel 18-8 Cage and Spring. Maximum Temperature of Liquid Pumped is 160°F (71°C).
Seal Liner Model 16C2-4045D: Copper Alloy C93700.
Shaft Sleeve Model 16C20-4045D: Alloy Steel 4130.
Flap Valve: Neoprene w/Steel Reinforcing.
Radial Bearing: Open Single Row Ball.
Thrust Bearing: Open Double Row Ball.
Bearing Lubrication: SAE 30 Non-Detergent Oil.
Suction Flange: Gray Iron 30.
Gaskets: Cork, Vegetable Fiber, Compressed Synthetic Fibers, and PTFE.
Hardware: Standard Plated Steel.
Standard Equipment: Hoisting Bail. Skid Base. 90° Ductile Iron Discharge Elbow. Strainer. Oil Level Sight Gauge (16C20-4045D Only).
Optional Equipment: High Speed (55 MPH/89 KM/H) Single Axle Pneumatic-Tired Wheel Kit w/wo DOT-Approved Lights and Electric Brakes. Single Axle Over-the-Road Trailer (Meets DOT Requirements) Available w/Either Electric or Hydraulic Surge Brakes, Running Lights, Jack Stands and Safety Cables. Battery.

*Consult Factory for Applications Exceeding Maximum Pressure and/or Temperature Indicated.



WARNING!
Do not use in explosive atmosphere or for pumping volatile flammable liquids.

ENGINE SPECIFICATIONS

Model: John Deere 4045D "Power Tech".
Type: Four Cylinder, Four Cycle, Liquid Cooled Diesel Engine.
Displacement: 276 Cu. In. (4,5 liter).
Governor: Mechanical.
Lubrication: Forced Circulation.
Air Cleaner: Dry Type.
Oil Reservoir: 9 U.S. Qts. (8,5 liter) Dry. 8 U.S. Qts. (7,6 liter) Refill.
Fuel Tank: 38.9 U.S. Gal. (147,3 liter).
Full Load Operating Time: 12.8 Hrs.
Starter: 12Volt Electric.
Standard Features: Low Oil Pressure and High Coolant Temperature Shut Down Switches/Indicators. Throttle Control. Instrument Panel Includes: Tachometer, Voltmeter, Hourmeter, Coolant Temperature and Oil Pressure Indicators, Start/Stop Key Switch, 10 Amp Fuse, Muffler w/Guard and Weather Cap.

JOHN DEERE PUBLISHED PERFORMANCE:
Maximum Gross Continuous 72 BHP (54 kW) @ 2500 RPM



THE GORMAN-RUPP COMPANY • MANSFIELD, OHIO
GORMAN-RUPP OF CANADA LIMITED • ST. THOMAS, ONTARIO, CANADA

www.grpumps.com

Specifications Subject to Change Without Notice

Printed in U.S.A.

Specification Data

SECTION 45, PAGE 1460

APPROXIMATE DIMENSIONS and WEIGHTS

SKID BASE **2-WHEEL**
NET WEIGHT: 2795 LBS. (1268 KG.) 3076 LBS. (1395 KG.)
SHIPPING WEIGHT: 2895 LBS. (1313 KG.) 3076 LBS. (1395 KG.)
EXPORT CRATE SIZE: 141 CU. FT. (4 CU. M.)

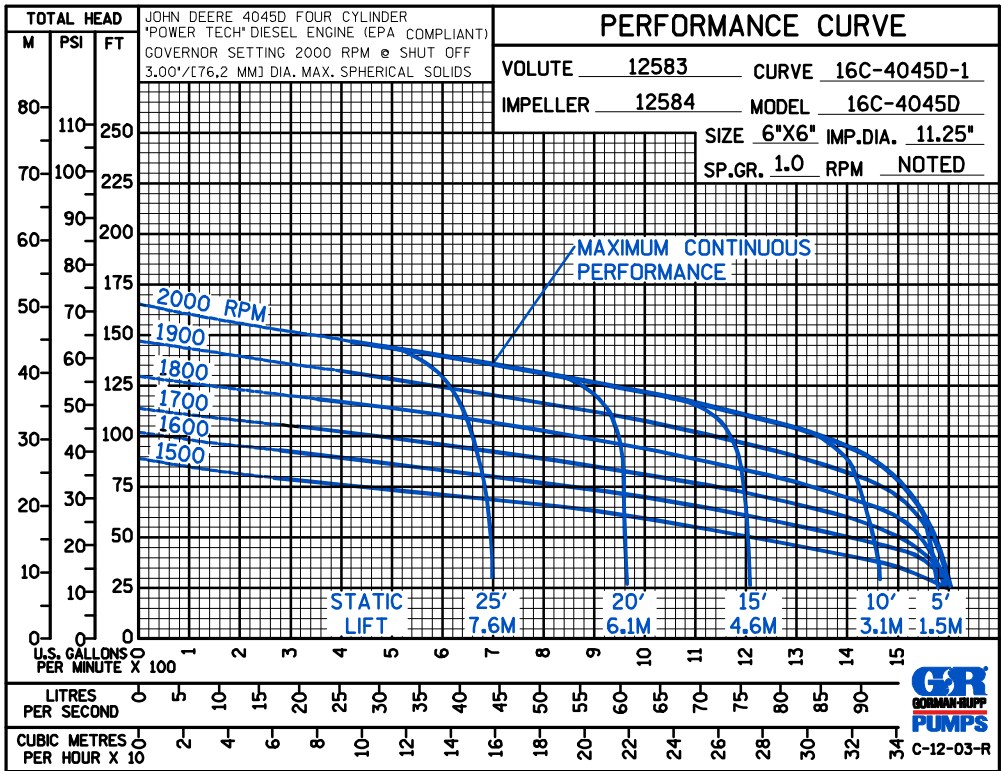
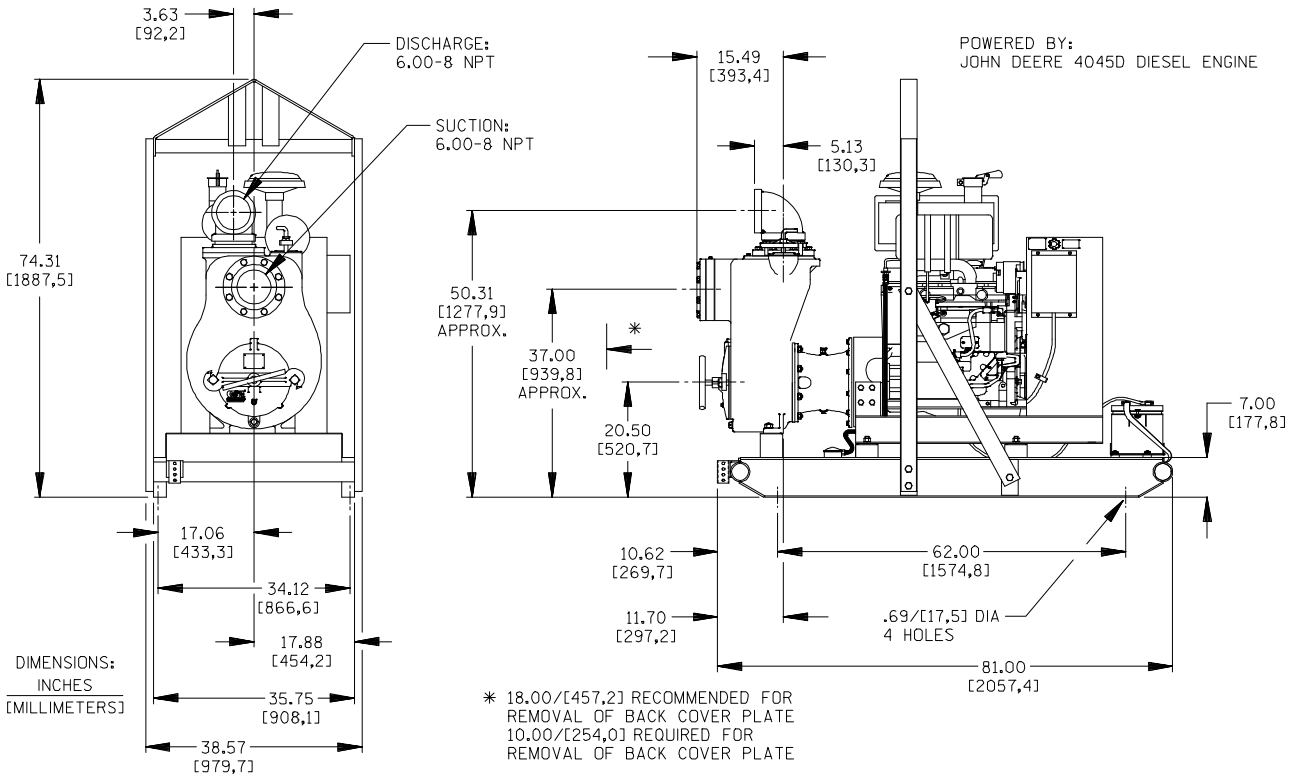

THE GORMAN-RUPP COMPANY • MANSFIELD, OHIO

GORMAN-RUPP OF CANADA LIMITED • ST. THOMAS, ONTARIO, CANADA

Specifications Subject to Change Without Notice

Printed in U.S.A.