

STANDARD DIMENSIONS(SECONDARY TANK)***				
CAPACITY GALLONS	LENGTH(L)	WIDTH (W)*	HEIGHT (H)**	WEIGHT
500	6' 8"	4' 7"	3' 9"	5,400 lb.
1,000	7' 9"	5' 7"	4' 9"	8,500 lb.
1,500	10' 7"	5' 11"	4' 9"	10,250 lb.
2,000	11' 10"	6' 11"	4' 9"	12,500 lb.

1. REFER TO DWG. SAC001 FOR TANKS 250 GALLONS.  
2. REFER TO DWG. SAC003 FOR TANKS 2,500 TO 20,000 GALLONS.

**NOTES:**  
 \*ADD AN ADDITIONAL 7" FOR OVERALL WIDTH.  
 \*\*ADD AN ADDITIONAL 9" FOR OVERALL HEIGHT IF INSTALLING SPILL BOX.  
 \*\*\*ADDITIONAL FITTINGS AVAILABLE UPON REQUEST.

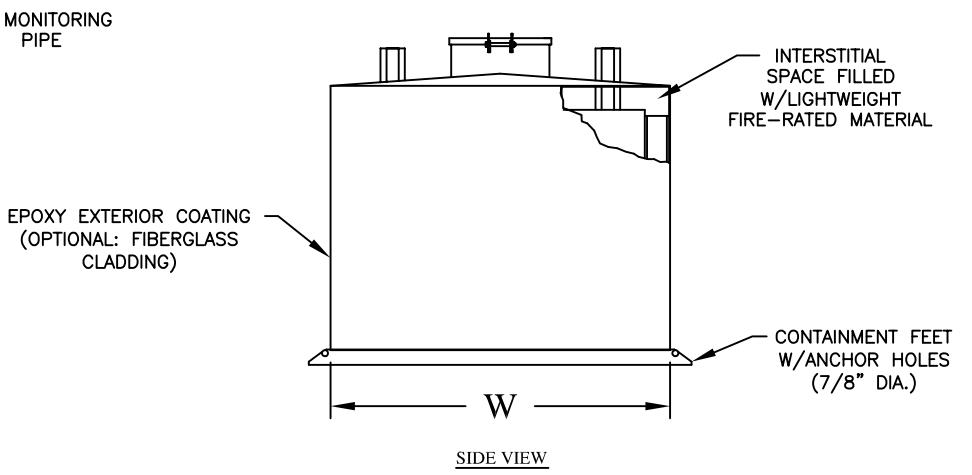
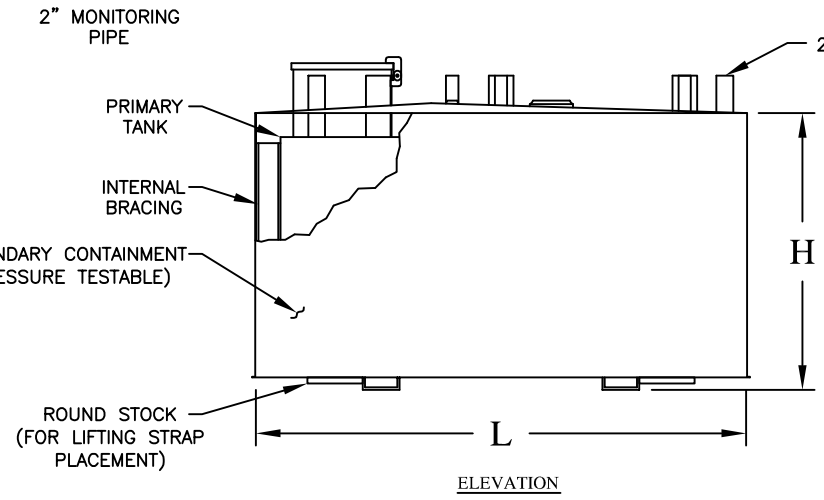

ENTIRE TANK ASSEMBLY IS UL-2085 LISTED (INSULATED SECONDARY CONTAINMENT ABOVEGROUND TANKS FOR FLAMMABLE LIQUIDS, PROTECTED TYPES).

PRODUCT CODE	GALLONS	DESCRIPTION	OVERALL SIZE	SHIP WT.
SAC002	SEE CHART	UL-2085 VAULT TANK	SEE CHART	SEE CHART
THIS DRAWING AND DESIGN SHOWN HEREIN IS THE PROPERTY OF CONTAINMENT SOLUTIONS. USE OR COPIES THEREOF CANNOT BE MADE WITHOUT WRITTEN CONSENT.				
CUSTOMER NAME	APPROVED BY: _____		DATE: _____	

**CONTAINMENT SOLUTIONS®**

DRAWN BY: D. ROVANG      DATE DRAWN: 01-01-14  
 DWG NUMBER: SAC002      SCALE: SALES  
 REV:      REV BY:      DATE:      SHEET: 1 OF 1