

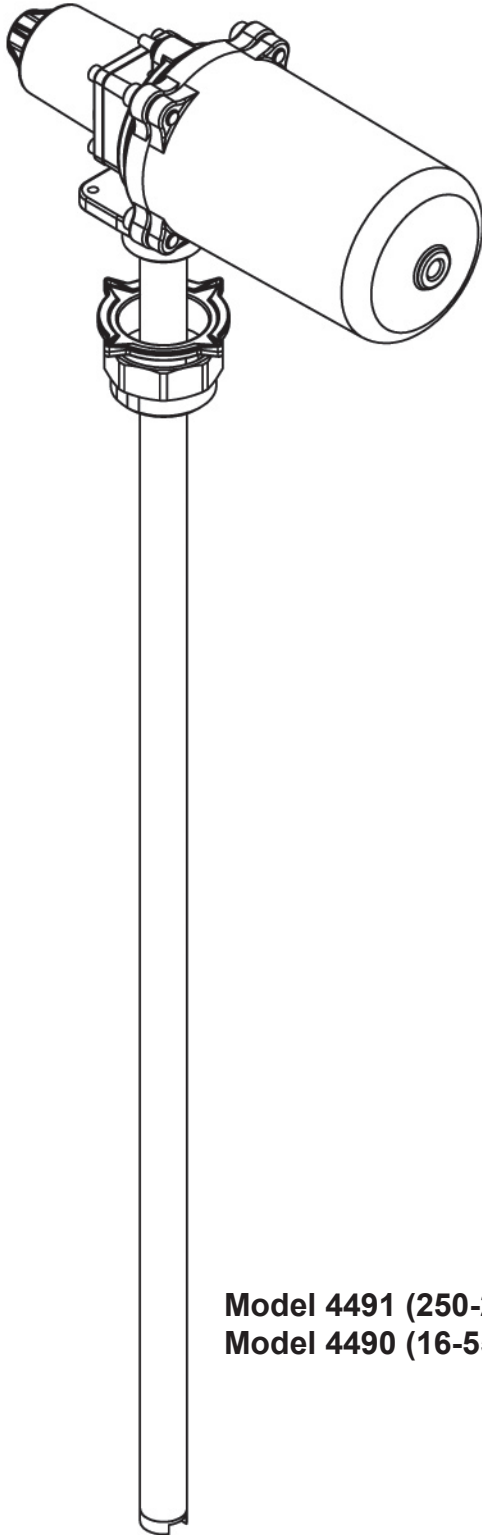

MODELS 4490, 4491, 4492  
3.5:1 AIR OPERATED PUMPS  
SERIES "A"

**SINGLE ACTION FLUID PUMP**



**Model 4491 (250-275 Gal)  
Model 4490 (16-55 Gal)**

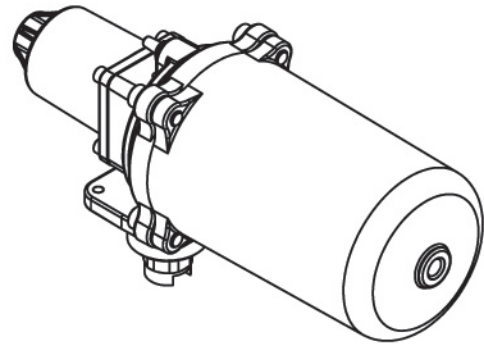

**Model 4492  
(Stub Pump)**



### **WARNING**

**FAILURE TO HEED THE FOLLOWING WARNINGS INCLUDING MISUSE, OVER PRESSURIZING, MODIFYING PARTS, USING INCOMPATIBLE CHEMICALS AND FLUIDS, OR USING WORN OR DAMAGED PARTS, MAY RESULT IN EQUIPMENT DAMAGE AND/OR SERIOUS PERSONAL INJURY, FIRE, EXPLOSION, OR PROPERTY DAMAGE.**

- Do not exceed the stated maximum working pressure of the pump or of the lowest rated component in your system.
- Do not alter or modify any part of this equipment.
- Do not operate this equipment with combustible gas or fuel, gasoline, diesel fuel, kerosene, etc.
- Do not attempt to repair or disassemble the equipment while the system is pressurized.
- Make sure all fluid connections are securely tightened before using this equipment.
- Always read and follow the fluid manufacturer's recommendations regarding fluid compatibility, and the use of protective clothing and equipment.
- Check all equipment regularly and repair or replace worn or damaged parts immediately.
- Never point the dispensing valve at any part of the body or at another person.
- Never try to stop or deflect material from dispensing valve or leading connection or component with your hand or body.
- Always check equipment for proper operation before each use, making sure safety devices are in place and operating properly.
- Always follow the pressure relief procedure after shutting off the pump, when checking or servicing any part of the system, and when installing, cleaning or changing any part of the system.

### INSTALLATION

Pumps are tested in light oil before shipment. To avoid system contamination, flush the pump with the lubricant to be dispensed before installing the pump.

Flush all supply lines, hoses, reels and fittings used in the dispensing system with mineral spirits or other petroleum based solvent to remove dirt, chips and other foreign matter that may damage the pump or other system components. The components should be blown dry with air after flushing.

Placement of a low restriction shut-off valve (such as a ball or gate valve) into the system between the pump outlet and overhead delivery system is recommended. This will allow the pump to be removed from the system for service without draining the entire system down.

Lincoln recommends using a mini regulator #602003 (1/4" NPT port size) with an air pressure gage #247843 in the air supply line to the pump to regulate the air pressure to the pump.

Lincoln does not recommend using Teflon tape pipe sealant when making connectins to this pump.

#### Bung Bushing Installation

- Apply pipe thread sealant to threads of pump tube and thread into 3/4 NPT female threads on bottom side of pump body. Tighten for leak free joint.
- Thread bung bushing into 2" NPT bung on top of reservoir drum or tank. (See illus. #2) Tighten bung bushing securely into bung thread. (Illus. #2 is illustrating a 55-gallon drum; other containers will be installed in a similar manner.)
- Insert pump tube through collet in bung bushing and place pump as close to bung bushing as possible. Pump tube should rest on bottom of drum or reservoir

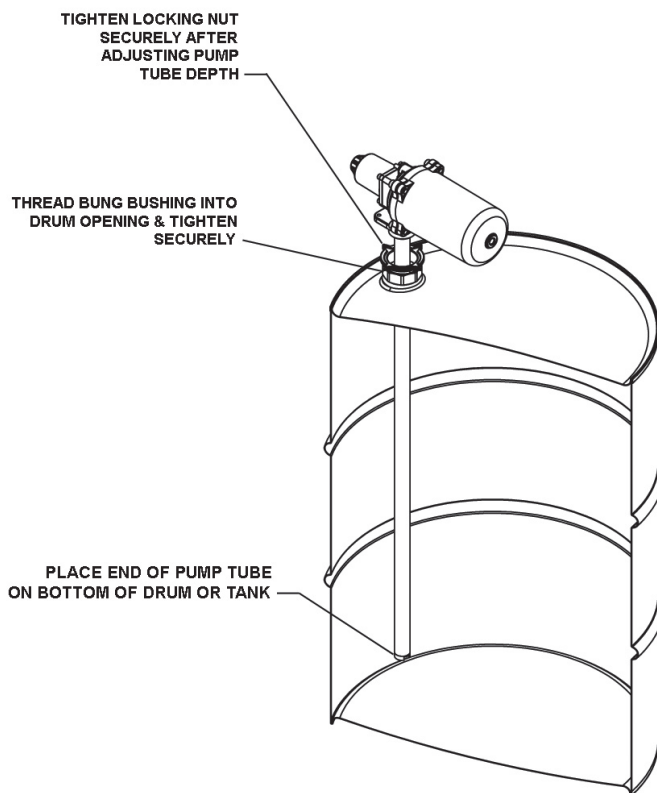

**Illustration 1**

#### **Bung Bushing Installation in Tank or Drum.**

Note: 55 Gal Drum Shown, 16 Gal, 250 Gal, & 275 Gal are similar.

# MODELS 4490, 4491, 4492

## 3.5:1 AIR OPERATED PUMP



- Position the pump as desired above the drum or tank, and tighten the lock nut securely so that collet locks the pump tube in place.

### Stand Pipe Installation

- Apply pipe thread sealant to threads of pump tube and thread into 3/4 NPT female threads on bottom side of pump body. Tighten for leak free joint.
- The use of a 1-1/2 NPT union is recommended for installation of the pump in a standpipe system. Enough clearance should be provided to clear the stub foot valve on the bottom side of the pump. (See illus. #2) A shut off valve should also be installed ahead of the pump standpipe so that the pump can be removed for service without the necessity of draining the tank for pump removal.
- Apply pipe thread sealant to 1-1/2 NPT male thread on bottom of pump body and thread into stand pipe union, tightening securely for leak free joint.
- Install the union onto the standpipe, adjust the position of the pump and tighten the union.
- Install connections to pump outlet. Open the shut-off valve ahead of the pump, and check for leaks. (All connections to pump outlet must be complete, and control valves must be closed before opening the valve between the pump and a full tank of lubricant. Otherwise the tank may be drained through the pump.)

The pumps may be used with suction tube configurations other than those listed above. Any alternate suction tube must include a check valve if the supplied pump tube is not going to be used. A 1" NPT female pipe thread is provided at the pump base for connection with alternate pump tube configurations.

Lincoln #85949 Universal Suction Kit includes a suction tube that may be cut to fit. A foot valve is also included with the kit.

Lincoln #84945 Remote Suction Kit includes a suction tube, hose, and bung bushing. A separate foot valve will have to be used with this kit. The remote kit will allow the pump to be mounted separate from the reservoir. A Lincoln #84940 Wall Bracket, for example, may be used to secure the pump to a wall or other stationary surface. The lubricant barrel can be easily changed without removing the entire pump from the lubricant reservoir.

### Thermal Expansion©

Oil distribution systems where the oil reservoir tank is remotely located from the piping and overhead hose reels, or where the piping system is located overhead and the reservoir is located at floor level may be subject to thermal expansion. Thermal expansion can occur where the oil reservoir is located in an area away from the remaining distribution system, and exposed to temperatures that are much lower than what the rest of the system is exposed to.

For example: where an oil reservoir is located outside a heated building, and the hose reels and piping system are located at ceiling level in a heated shop. When the cool oil is pumped from the reservoir into the warm building and allowed to warm up, the oil will expand. The oil has no place to expand, because it is trapped between the pump's check valves and the control valves on the end of the dispensing hose. As the oil warms and expands, the pressure will rise. When there is an extreme temperature difference, the pressure may rise to a level beyond the ratings of the system components, causing damage to the plumbing or other components in the system.

Thermal expansion may also occur when any system that is stalled against pressure, remains inactive when a large temperature rise occurs. As above, the oil pressure in the system will rise, as it warms, and can cause system or component damage if the pressure exceeds the system component pressure ratings.

Lincoln recommends that a 500 PSI pressure relief valve, such as Lincoln P/N 275197, be installed into the fluid connections from the pump outlet. A pipe tee can be added at the pump outlet and the relief valve connected into the tee, with the connection from the distribution system connected into the remaining outlet in the tee. The return to tank connection on the relief valve should be routed back to the oil reservoir tank.

When the 275197 valve is properly installed, should the pressure rise above the cracking pressure of the relief valve (500 PSI), the valve will open and vent the oil back to the reservoir tank, therefore protecting the system from over pressurization. The relief valve will close when the pressure drops to about 400 PSI. Normal operation of the distribution system should not be affected when the valve actuates.

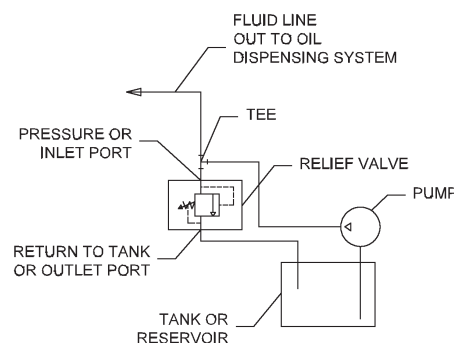

© VALVE CONNECTION SCHEMATIC

© **WARNING**

Thermal expansion of oil can damage components of the lubrication system. Install pressure relief valve Lincoln P/N 275197.

© Indicates change

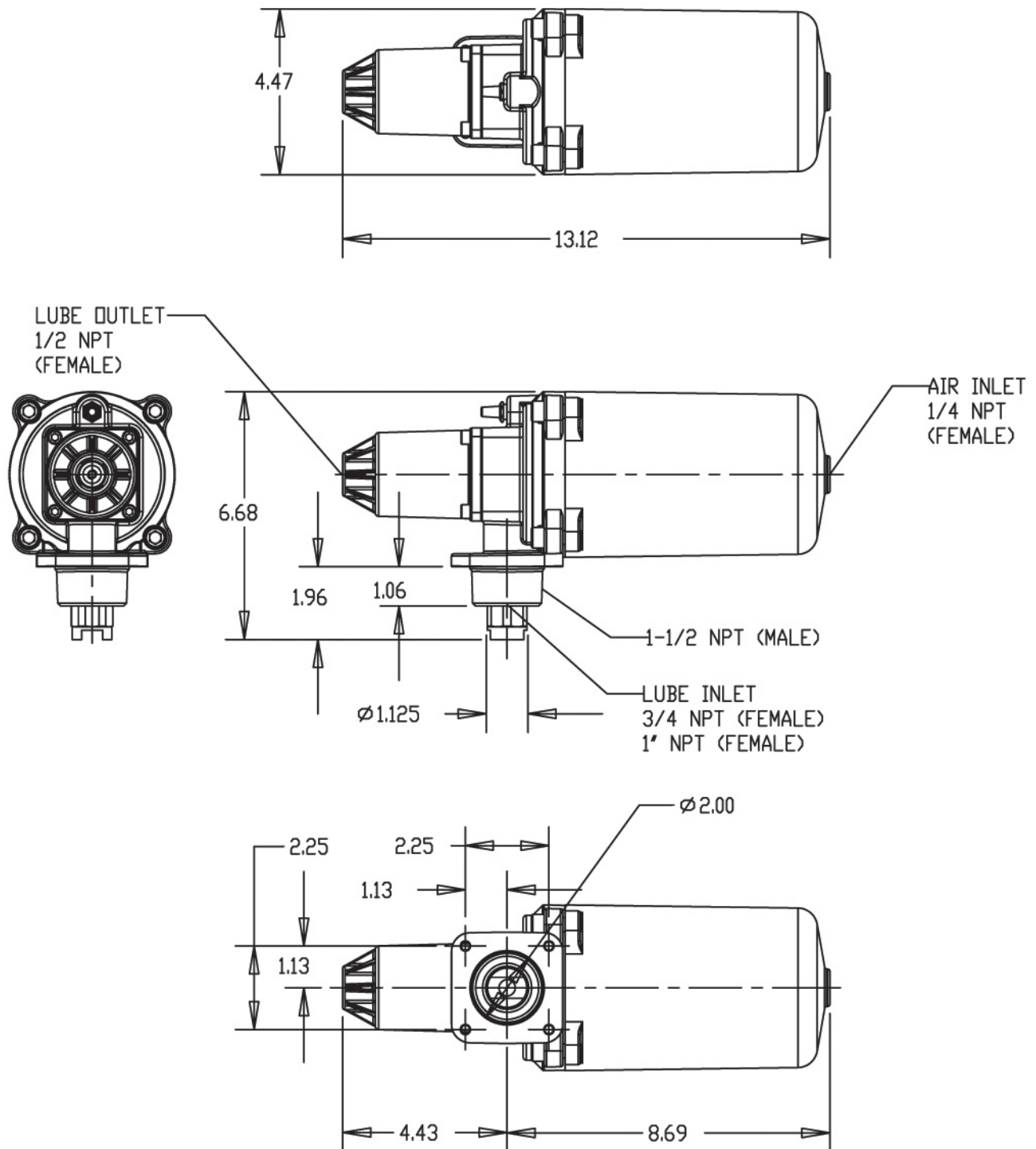

**Model 4492  
Stub Pump  
Illustration #2**

**MODELS 4490, 4491, 4492**  
**3.5:1 AIR OPERATED PUMP**

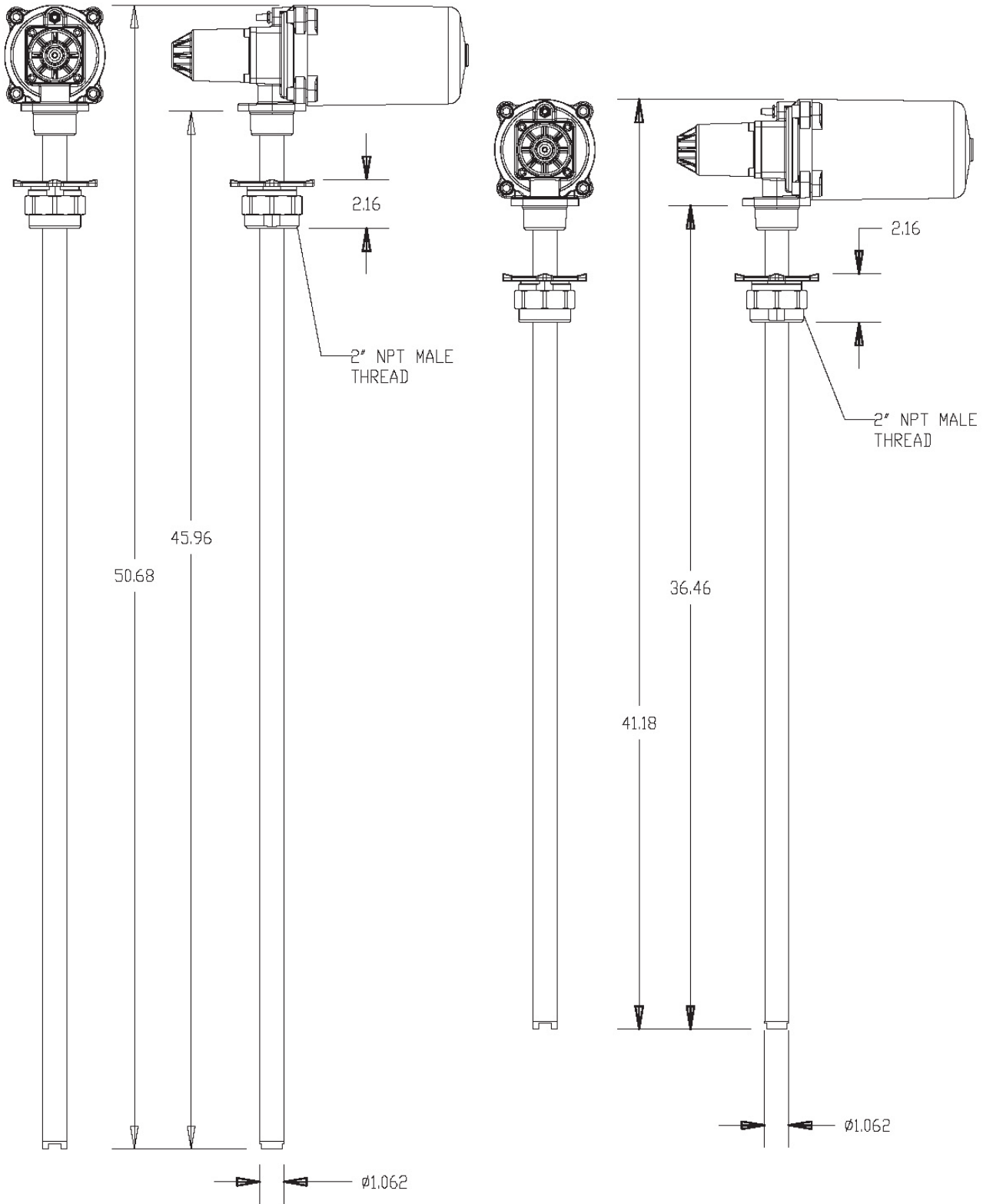

**Model 4491**  
**250-275 Gallon**  
**Illustration 3**

**Model 4490**  
**16-55 Gallon**  
**Illustration 3**



### SYSTEM START-UP

When operating the pump in a system for the first time, air must be purged from the system. Expelling air from the pump is very critical for the pump to prime and operate reliably. Before connecting the pump to a system, make sure the pump is placed into a container of the oil that is to be dispensed. Connect a short length of hose to the pump outlet and direct the open end of the hose into a container to catch the oil. Operate the pump at low air pressure, 20-40 PSI, until the pump primes, and oil flows smoothly from the end of the hose.

The system can now be connected to the pump outlet. Purge the entire system in a similar manner, slowly pumping oil through all reels and control valves until oil, free of air, flows smoothly from each outlet.

### PRESSURE RELIEF PROCEDURE

The following procedure should be followed when it becomes necessary to shut the system down for service or container changes.

- Disconnect the air supply from the air inlet of the pump.
- Bleed the lubricant pressure off the system by opening a dispensing valve into a container. Hold the valve open until all flow from the system stops.
- Close the shut-off valve between the pump and reservoir on standpipe installations (if present).
- Close the shut-off valve between the pump outlet and supply lines (if present).
- Slowly loosen the lubricant supply line at the pump outlet. A very small volume of oil will leak from the threads. If pressure is present, stop the loosening procedure and repeat the steps above.

### REPAIR

Repair is limited to the service parts listed on following pages. In most cases, service is going to be the replacement of soft seals in the pump. See illus. 5 and 6 for internal components of the pump. Illus. 5 indicates the disassembly/re-assembly order of the pump. Illus. 6 indicates how all components fit together and the correct placement of seals.

Contact your nearest authorized Lincoln Service Dealer or Lincoln Technical Services for assistance.

### Disassembly Procedure

- Follow Pressure Relief Procedure, above to remove all pressure from the pump and related system.
- Disconnect air and supply lines from the pump and remove from reservoir.
- On pumps with long pump tubes, remove the pump tubes from the pump inlet.
- Carefully secure the pump in a vise holding at the pump base. Take care not to damage the pump base or other components.

- Loosen Allen head cap screws, (item #1), and remove. Remove fluid cylinder (item #2) and set aside O-ring (item #3).
- **Make sure that fluid plunger components, (items #4 thru #9) are securely attached to piston rod ass'y, (item #18).**
- Loosen Allen head cap screws (item #14). **Make sure that the screws and air cylinder are not under spring tension before removal of screws.** Pull air cylinder (item #21) away from pump body (item #15) before screws are completely removed to make sure cylinder is not under tension.
- Remove air cylinder (item #21) and remove air piston assembly (item #19) from air cylinder. Use a rod through air inlet hole to gently push piston from cylinder. [Air plunger, (item #19) is a sealed unit. Internal seals in the air plunger are not replaceable. If problems are suspected with the air plunger, the entire plunger must be replaced as a unit.]
- Spring (item #16) is now retained by the fluid plunger components, (items #4 thru #9), only. With assistance from another person, push the piston rod assembly (item #18) slightly into pump body to relieve tension from fluid piston components, (items #4 thru #9). Hold piston rod with wrench on flats provided, and remove the fluid piston nut (item #4). Gently remove the spring tension by allowing the plunger rod to pull out of the pump body (item #15).
- Once spring tension is removed, remaining components may now be removed from the pump body. (Piston Rod Assembly, (item #18) is permanently assembled in two pieces at the factory, do not attempt to disassemble any further.)
- Remove retaining ring (item #10) and washer (item #11). The U-cup seal (item #12) may now be removed from the pump body, taking care not to damage surfaces of seal bore.
- Once all components are disassembled, clean with mineral spirits or other suitable solvent. Replace all replaceable seals and worn parts.
- Reassembly will be the reverse of the above procedure.
- NOTE: When installing U-Cup seal (item #12) special care is required to place the seal in the bore correctly. The seal lips must face the outlet end of the pump, as seen in Illus. 6. Make sure that retaining ring (item #10) is properly seated when reinstalled.

Contact your nearest authorized Lincoln Service Dealer or Lincoln Technical Services for assistance.

When ordering replacement parts, order by part number and description. The model number and series letter may also be required.

MODELS 4490, 4491, 4492  
3.5:1 AIR OPERATED PUMP

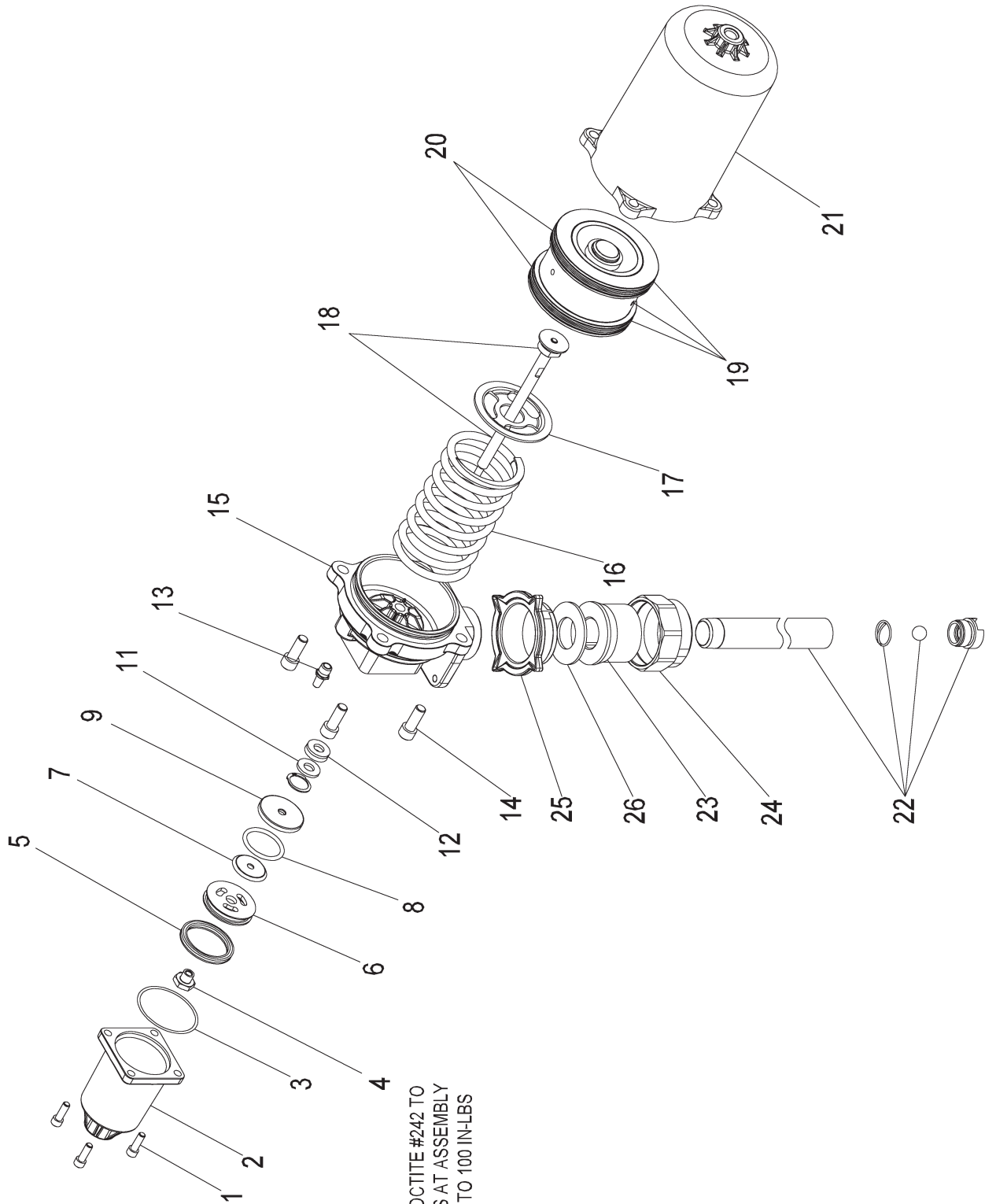

APPLY LOCTITE #242 TO  
THREADS AT ASSEMBLY  
TORQUE TO 100 IN-LBS

Illustration #5



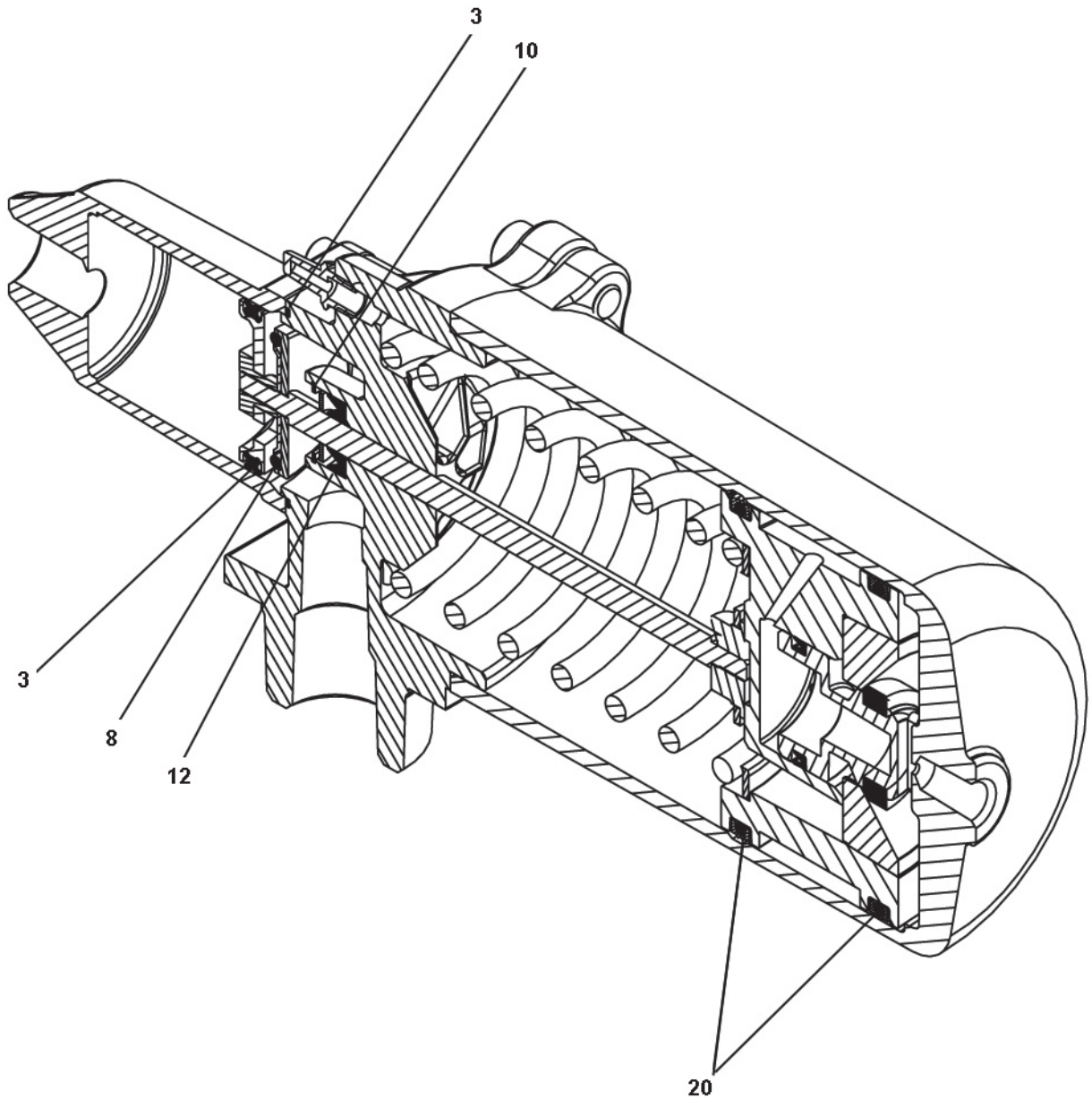

Illustration #6

**MODELS 4490, 4491, 4492**  
**3.5:1 AIR OPERATED PUMP**



**SERVICE PARTS**

PART NO	ITEM	DESCRIPTION	QUAN
274095	1	1/4-28 X 3/4" SOC HD CAP SCREW	4
274079	2	FLUID CYLINDER	1
274107	3	O-RING, FLUID CYL. (NITRILE)	1
	5	SEAL, PISTON (NITRILE)	1
	8	O-RING, PISTON CHECK (NITRILE)	1
	12	U-CUP, ROD SEAL (POLYURETHANE)	1
	20	SEAL, AIR PISTON (POLYURETHANE)	2
274078	4	NUT, FLUID PISTON	1
274077	6	FLUID PISTON	1
274081	7	RETAINER, O-RING	1
274076	9	CHECK WASHER	1
274082	10	RING, RETAINING	1
274311	11	WASHER	1
272580	13	MUFFLER KIT	1
274084	14	3/8-16 X 1" SOC HD CAP SCREW	4
274067	15	PUMP BODY	1
274069	16	SPRING, PISTON RETURN	1
274075	17	RETAINER, SPRING	1
274072	18	PISTON ROD ASSY	1
274066	19	PISTON ASSY, AIR	1
	20	SEAL, AIR PISTON (POLYURETHANE)	2
274070	21	CYLINDER, AIR	1
261170	22	SUCTION TUBE ASS'Y MODEL 4490	1
274085		SUCTION TUBE ASS'Y MODEL 4491	1
274087		SUCTION TUBE ASS'Y MODEL 4492	1
274219	23	COLLET	1
261103	24	BUNG BUSHING	1
261104	25	BUNG CAP	1
273035	26	COLLET WASHER	1



**TROUBLESHOOTING**

<b>Conditions</b>	<b>Possible cause</b>	<b>Corrective action</b>
The pump doesn't operate.	No inlet air pressure.	Connect air supply.
	The piston is stuck.	Disassemble the pump inspect for damage, relubricate. Replace if necessary.
	Air pressure is too low.	Check air pressure supply. The pressure is to be higher than 20 Psig.
	Broken return spring	Replace if necessary.
The pump cycles but doesn't deliver fluid.	Loss prime	Repeat priming operation
	The container is out of liquid.	Check that container has fluid.
	The ball check valve is not functioning.	Disassemble check valve, remove ball, clean and inspect ball seat area.
The pump still doesn't operate.		Contact an authorized service center.

**MODELS 4490, 4491, 4492  
3.5:1 AIR OPERATED PUMP**



---

**Declaration of Conformity as defined by Machinery Directive 98/37/EG Annex II A**

This is to declare that the design of the Single Action 3.5:1 Air Operated Pumps (models 4490, 4491 & 4492) complies with the provisions of Directive 98/37/EG

**Applied Standards:**

- EN 292-1 Safety of Machinery - Basic Concepts, General Principles and Design - Part 1: Basic Terminology, Methodology
- EN 292-2 Safety of Machinery - Basic Concepts, General Principles and Design - Part 2: Technical Principles and Specifications - Incorporates amendments 1 (1995) and 2 (1997)
- EN 809 Pumps and Pump Units for Liquids - Common Safety Requirements

*Paul M. Conley*

---

St. Louis, MO 04/28/05, Paul Conley, Chief Engineer

Americas:  
One Lincoln Way  
St. Louis, MO 63120-1578  
USA  
Phone +1.314.679.4200  
Fax +1.800.424.5359

Europe/Africa:  
Heinrich-Hertz-Str 2-8  
D-69183 Walldorf  
Germany  
Phone +49.6227.33.0  
Fax +49.6227.33.259

Asia/Pacific:  
51 Changi Business Park  
Central 2  
#09-06 The Signature  
Singapore 486066  
Phone +65.6588.0188  
Fax +65.6588.3438

© Copyright 2005  
Printed in USA

Web site:  
[www.lincolnindustrial.com](http://www.lincolnindustrial.com)