

Heavy-duty LED light cord reel

Lincoln is introducing the latest in high intensity LED technology with its new heavy-duty cord light reel. The 15 m (50ft.) cord gets light and power where and when it is needed with easy retraction for out-of-the-way storage.

Benefits

- Efficient illumination
 - LEDs provide excellent illumination, consume less power and have a much greater service life than either fluorescent or incandescent lighting options.
- Durability
 - Hand lamp features a shatter-resistant light tube and heavy-duty inline molded tool tap.
- Convenience
 - Tool tap provides portable power to electric tools and plug cap keeps debris out of plug when not in use.
- Long service life
 - Steel reel parts are painted at the component level prior to assembly with a durable, baked-on powder-coat paint. The end result is a protective finish that will look great through years of service.

Specifications

- Two 4 Watt, high-output LEDs provide bright, even light over the work surface.
- 1 Watt lensed output LED flashlight at the end provides bright light in tight spaces.



*Model shown:
91035*

- Models supplied with cord include 1,2 to 1,5 m (4 to 5 ft.) pigtail and NEMA-15 plug.
- Adjustable cord stop.
- Guide arm easily adjusts to facilitate ceiling, wall or bench mount with only standard tools.
- Polycarbonate impact- and shatter-resistant light tube.
- Quiet speed-latching mechanism maintains desired working length of cord.
- Baked-on, corrosion- and chip-resistant powder-coat paint finish.
- Inline molded tool tap capable of drawing up to 13 A (maximum).
- Protected two-way on/off switch located on handle.
- Suited for indoor applications only.



*Model 278557-
340° pivot base
(optional)*



*Model 278558 -
wall-mounted swing
bracket (optional)*

Heavy-duty LED cord reels

Reel dimensions

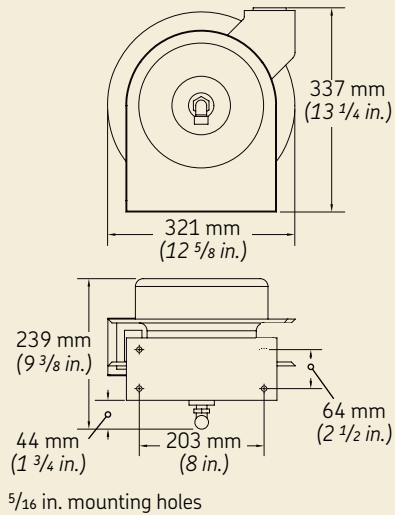

Heavy-duty LED cord reel models

Maximum temperature 99 °C (210 °F), 125 V, 13 A

Model with cord	Cord ending	Cord specifications						Shipping weight	
		AWG	mm ²	# cond.	m	ft.	Type	kg	lbs.
91035	LED with inline outlet (model 278556)	16	1.33	3	15	50	SJTOW	13	28

For indoor applications only. Optional wall-mounted swing bracket (model 278558) should be used if cords are pulled at more than a 45° angle.

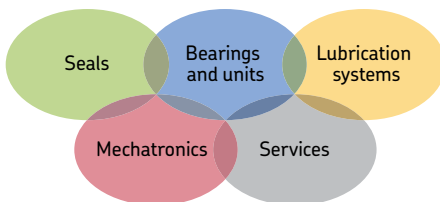

The Power of Knowledge Engineering

Drawing on five areas of competence and application-specific expertise amassed over more than 100 years, SKF brings innovative solutions to OEMs and production facilities in every major industry worldwide. These five competence areas include bearings and units, seals, lubrication systems, mechatronics (combining mechanics and electronics into intelligent systems), and a wide range of services, from 3-D computer modelling to advanced condition monitoring and reliability and asset management systems. A global presence provides SKF customers uniform quality standards and worldwide product availability.

Please contact:

SKF USA, Inc.

One Lincoln Way

St. Louis, MO 63120 USA

Tel. +1 (314) 679-4200

© SKF is a registered trademark of the SKF Group.

© Lincoln is a registered trademark of Lincoln Industrial Corp.

© SKF Group 2013

The contents of this publication are the copyright of the publisher and may not be reproduced (even extracts) unless prior written permission is granted. Every care has been taken to ensure the accuracy of the information contained in this publication but no liability can be accepted for any loss or damage whether direct, indirect or consequential arising out of the use of the information contained herein.

SKF PUB LS/P2 13866 EN · June 2013 · FORM 444584

LINCOLN

SKF