

Materials

Body: Brass

Internal Components: Stainless steel

Seals: Specially formulated polymers and elastomers specific to high-pressure NGV applications.



VLB

Features

- ◆ **Durable, Corrosion-Resistant Construction** - hardened brass construction provides excellent durability and corrosion resistance in harsh refueling environments.
- ◆ **Reconnectable Design** - allows the component to be reused, reducing maintenance costs.
- ◆ **For Vent Hose Only** - design not pressure balanced. Must be at least 8 feet from nozzle vent outlet.
- ◆ **Prevents Excessive Back Pressure on Nozzle Vent Line** - maximum pressure of 350 ± 50 psi (24 ± 3.5 Bar).
- ◆ **Easy Installation** - the vent line breakaway has SAE-6 female ports for easy installation.
- ◆ **Disconnection Force** - 70 lbs. (312 N).

Specifications:

Temperature Range: -40° F to 185° F
(-40° C to 85° C)

Weight: 0.72 lb. (0.330 kg)

Cv: 3.25

Design Pressure: 350 psi (24 Bar)

OPW Vent Line Breakaway (VLB)

The VLB is a simple, in-line breakaway that fits into the nozzle vent line. This unit will function consistently when used in conjunction with OPW high pressure In-Line Breakaways. It allows for 360° swivel. It contains no internal check valves and therefore does not contain hose pressure in the event of a drive-away.

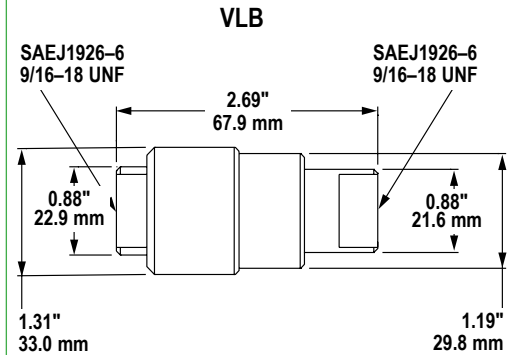

Ordering Specifications

Product No.	Inlet Thread Size	Outlet Thread Size	Max. Allowable Service Pressure
VLB	SAE - 6, 9/16 - 18 UNF	SAE - 6, 9/16 - 18 UNF	350 psi 24 bar