

Materials

- Body ring:** Cast iron
- Cover:** Cast iron
- Skirt:** Galvanized steel



OPW 104A Cast Iron Manhole

A sturdy steel skirt on the standard 104A extends nearly a foot below grade to ensure trouble-free installation in deep concrete, and optional skirts that extend a full 19-1/4" below grade are available in 12" and 18" diameters for sandy soil locations.

OPW 104FG Cast Iron Manhole

The 104FG provides a convenient finger grip feature on the cover to facilitate cover removal.

Features

- ◆ Full-size internal diameters for maximum access and working area
- ◆ Highway 20 Rated (H20) – All OPW spill containers and manholes exceed the requirements of the Highway 20 rating
- ◆ Rugged cast iron covers and body rings
- ◆ Cast-in, non-skid finish on covers
- ◆ Sturdy, extra long steel skirts
- ◆ Individually boxed for ease of handling

Ordering Specifications

Product #	ID (in.)	ID (mm)	lbs.	kg
104A-0800	8	203	15	6.8
104A-0800WT	8	203	15	6.8
104A-1200	12	305	28	12.7
104A-1200WT	12	305	33	15.0
104A-1219	12	305	33	15.0
104FG-1200*	12	305	28	12.7
104FG-1219*	12	305	33	15.0
104A-1800	18	457	50	22.7
104A-1800WT	18	457	50	22.7
104A-1819	18	457	57	25.9
104A-1819WT	18	457	57	25.9
104A-12WT	12	305	28	12.7

* Finger Grip Cover Manhole

Replacement Parts

Part #	Description	Obsolete Bucket	Replacement Lid	Cover O.D.
E00508M	Cover for 8" 104A-0800	104A-1022	C00115M	8.44"
E00510M	Cover for 12" 104A-1200	104A-1066	D00173M	13.125"
E00584M	Cover for 12" 104FG-1200	104AC-1586	D00173I	13.125"
E00512M	Cover for 18" 104A-1800			
DO1747M	Cover for 20" 104C-2000			

OPW 104 Series Cast Iron Manholes

Heavily ribbed cast iron covers and body rings ensure maximum load bearing capacity on cast iron manholes and fill boxes. These manholes are ideal for connecting underground tank lines directly to the surface without sump enclosures. A variety of features available on cast iron manholes and fill boxes make them the perfect choice for many applications.

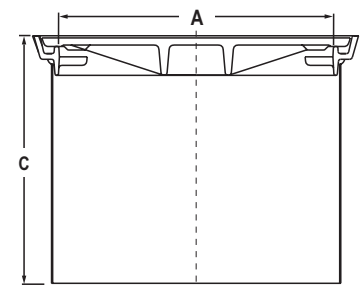

OPW 104A/FG Cast Iron Cover Manholes

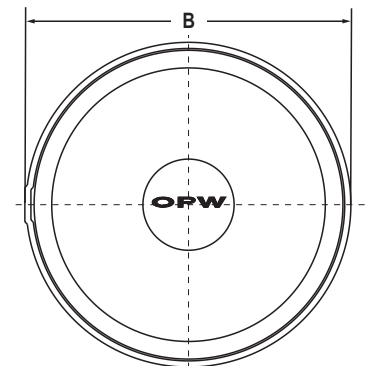

OPW 104A & 104FG Cover

Dimensions

Product #	A		B		C	
	in	cm	in	cm	in	cm
104A-0800	8	20.3	10 ¹ / ₈	25.7	11 ¹ / ₄	28.6
104A/FG-1200	12	30.5	14 ¹ / ₄	36.2	11 ¹ / ₄	28.6
104A/FG-1219	12	30.5	14 ¹ / ₄	36.2	19 ¹ / ₄	48.9
104A-1800	18	45.7	20 ¹ / ₈	51.1	11 ¹ / ₄	28.6
104A-1819	18	45.7	20 ¹ / ₈	51.1	19 ¹ / ₄	48.9