

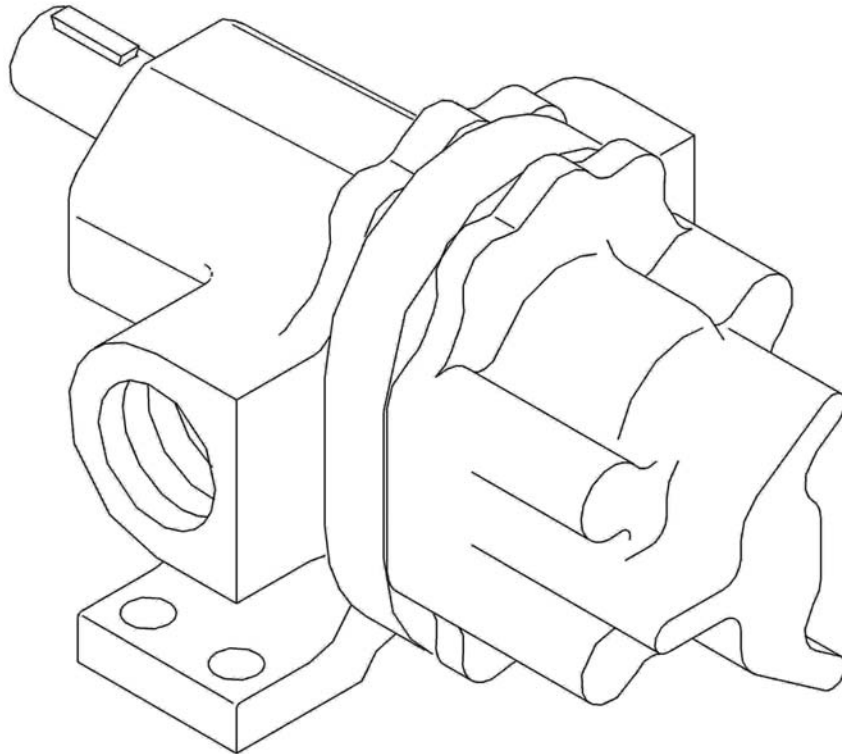

AM, AP & AL SERIES PUMPS OWNERS MANUAL

G12-207

2/2/04



SAFETY INSTRUCTIONS

This is an industrial component. Only a qualified systems integrator should be allowed to design it into a system. The integrator must determine proper plumbing, mounting, driveline and guard components.

Improper installation or use could lead to a serious, even fatal, accident. The system integrator must communicate all safe operation procedures to the end user(s).

Before operation, fully understand and follow the instructions shown in this manual and any instructions communicated by the system integrator. No one should be allowed to operate or maintain this pump who has not been fully trained to work safely according to the configuration of the pump system and in accordance with all applicable government and industry regulations.

**Roper Pump Company
P.O. Box 269
Commerce, GA 30529 USA**

**Telephone: (706) 335-5551
TeleFAX: (706) 335-5490
Email: sales@roperpumps.com
www.roperpumps.com**

INSTALLATION

Check Ports Versus Rotation:

Make sure the inlet and outlet ports have been correctly plumbed corresponding to the direction of rotation. See figure below for various configurations.

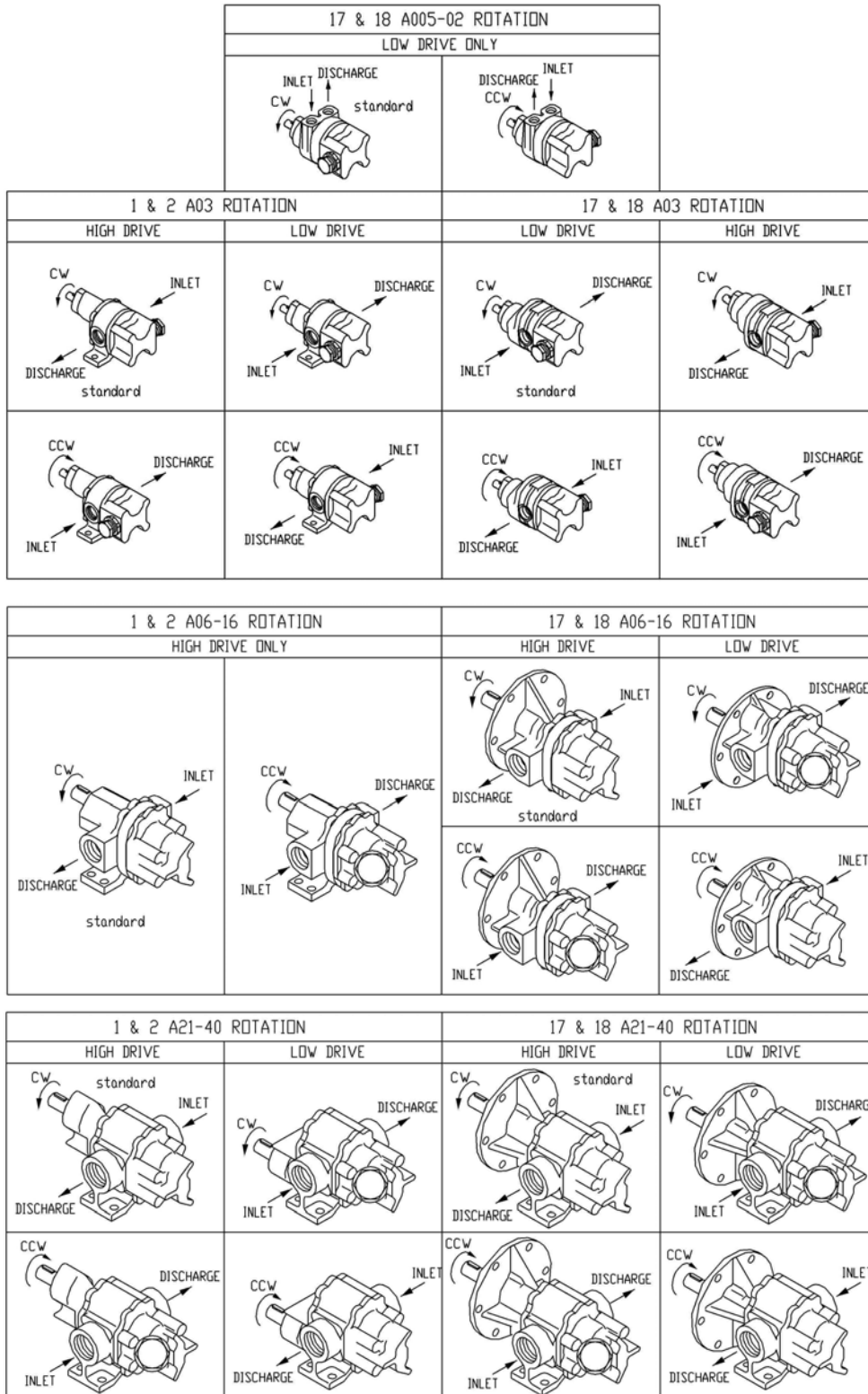

Good Practice

NOTE: These are general guidelines and do not cover all possible situations.

It is the responsibility of the system integrator to apply this product properly.

Plumbing

1. The inlet pipe should be as short and straight as possible to minimize suction pressure losses. Excessive restrictions at the inlet can cause cavitation resulting in poor performance, noise, vibration, or pump damage.
2. Slope the inlet plumbing appropriately to avoid air pockets.
3. Plumbing weight, misalignment with the ports or thermal expansion can exert excessive force on the pump. Plumbing must be properly supported and aligned with expansion joints, if required, to minimize these forces.
4. To prevent over pressure situations, install a relief valve as close to the pump outlet as possible. Install the relief valve before any shut-off valves.

Separate Pump and Drive Assemblies

Driveline Guards

1. Assure adequate guards have been installed to prevent personnel contacting moving components.
2. Follow all OSHA, Federal, state and local codes.

Check Alignment of Pump to Driveline

Excessive misalignment can overload the pump input shaft and cause premature failure. The figures below show parallel and angular misalignments.

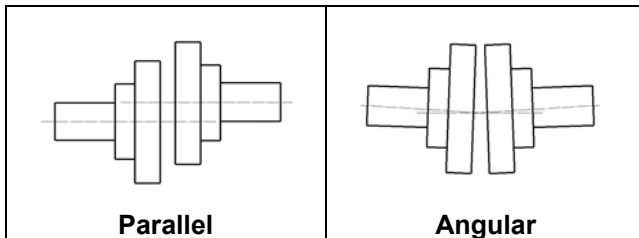

Mounting Base

1. Mount the unit on a rigid, heavy base to provide support and absorb shock. Bases should be designed for high rigidity, not just strength.
2. The pump feet were not designed for mounting to concrete and do not have enough contact area to prevent concrete from failing. When mounting to cement or concrete, use a steel base plate (supplied by others) to distribute the mounting stress over an area large enough to prevent the cement from failing. The base plate should be at least as thick as the pump feet. Grout it in place.

Roper Pumps' Close Coupled Drives

Units where the drive mounts directly to the pump

- Exposed drivelines require guards.
- Alignment between pump and drive line is maintained by the assembly.
- Because the assembly absorbs reaction forces of the driveline, the mounting base does not need to be as robust. The level of rigidity and strength is determined by the piping stresses from the system.



Over-pressure may burst pump or system components. Always include a relief valve in installation. Do not over pressurize pump or block discharge line while running.



Operating without guards could result in serious injury or death. Machinery in operation can grab, crush, cut, mangle and dismember. Do not operate without adequate guards in place.

PUMP RATINGS

Maximum Ratings				
Pump Size	Flow Rate GPM	Pressure PSI	Temperature °F	Input Speed RPM
005	1.8	300	212	3600
01	3.6	300	212	3600
02	7.6	300	212	3600
03	11.6	300	212	3600
06	11.2	150	212	1800
08	16.3	150	212	1800
12	23.5	150	212	1800
16	30.8	150	212	1800
21	40.2	150	212	1800
27	49.8	150	212	1800
32	59.1	150	212	1800
40	75.6	150	212	1800

RELIEF VALVE

SIZES 005 thru 03

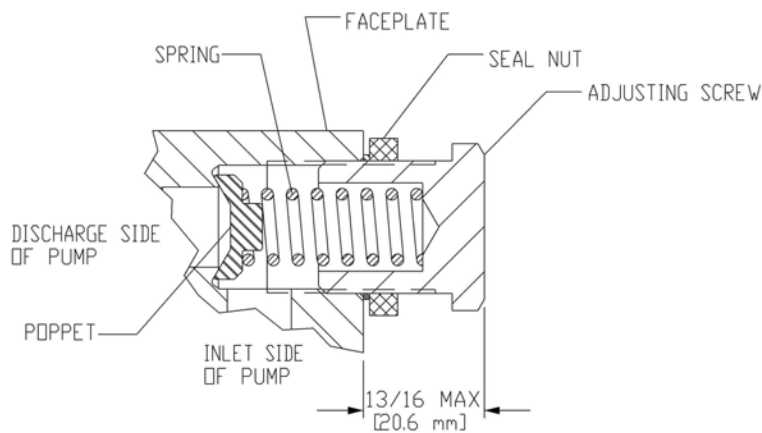

SIZES 06 thru 40

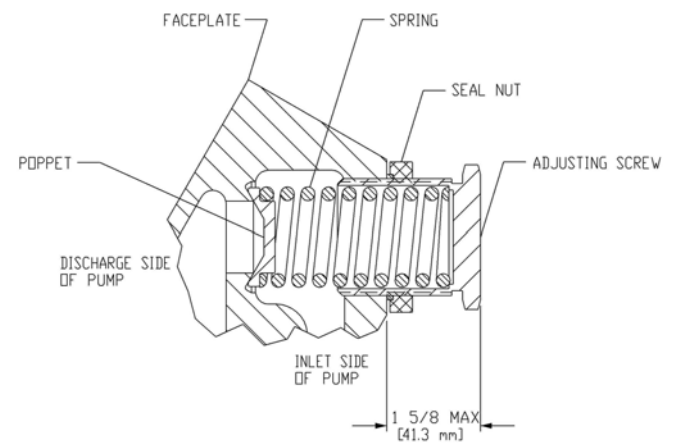

The relief valve must be positioned as shown in instructions for direction of rotation – otherwise the valve is inoperable, discharge pressure will not be working against the relief valve.

If the built-in relief valve is used, it is mandatory that the relief valve be set BY THE USER, since maximum relief valve pressure depends upon the viscosity and specific gravity of the liquid, the flow rate (pump RPM), and also the initial relief valve setting.

NOTE: The fact that the pump has the correct rotation and discharges liquid thru the desired port does NOT insure that the relief valve is installed in the correct position, or that it has the correct setting for the application.

TO ADJUST RELIEF VALVE

Warning: Take precautions necessary to prevent personal injury or physical damage that could be caused by any loss of the product being pumped while adjusting relief valve.

DO NOT adjust relief valve without all guards in place.

Relief valve must be adjusted under conditions identical to the operating conditions (Viscosity, RPM, etc.)

1. Connect a pressure gauge near the pump in the discharge line between the pump and the point where the discharge line will be closed. (Some pumps have tapped and plugged holes in the case near the outlet which may be used for this connection.)
2. Loosen the sealing nut on the adjusting screw.
3. Back the adjusting screw out to the point where the end of the adjusting screw will be as shown on the Relief Valve drawing.
4. Start pump and close discharge line slowly. Do not exceed pressure rating of pump or other equipment between pump and discharge line valve. If this pressure is reached while closing the discharge valve, do not close any further. (This might occur with very high viscosity liquids.) It would then be necessary to install a separate relief valve in the system for protection. Do not run pump with closed discharge line for more than two minutes at a time.
5. With discharge valve closed, turn adjusting screw clockwise in $\frac{1}{2}$ turn increments until the pressure gauge shows the desired pressure setting.
6. Tighten sealing nut.
7. Open discharge line, and turn pump off.

Relief valve is now set.

To replace spring and/or poppet, shut pump off, decrease the pressure on the spring and remove the plug cap by unscrewing it from the faceplate. After inspecting parts and replacing those required, reassemble the parts in reverse order to which they were removed, making sure the spring is centered on poppet and guide. Replace gasket and screw the plug cap into position and adjust pressure to desired setting. Tighten sealing nut.

A built-in relief valve should not be used on applications where the discharge must be closed for more than a few minutes. Prolonged operation with the relief valve fully by-passing will cause heating of the liquid circulating thru the valve, thus resulting in possible damage.

MECHANICAL SEAL (AM) PUMPS

Mechanical seals do not require adjustment. Leakage developed at the seal may be due to one of the following conditions: worn, marred, or cracked rotating or stationary seal face, or bellows that have become hard, soft, cracked, expanded or extruded.

When replacing or servicing a mechanical seal, take particular care not to mar or scratch the sealing surfaces or injure the bellows. If the seal has been used, do not put it back into service unless both sealing surfaces are perfectly flat and smooth or else replaced.

To replace the mechanical seal, remove the key, cap screws, and bearing cage assembly (AM005 thru AM03) or seal retainer (AM06 thru AM40). Remove burrs and sharp edges from the end of shaft and keyway and clean the shaft. Next, the seal rotating parts may be removed from the shaft.

AM005-AM03

To reassemble the mechanical seal on pump sizes AM005 thru AM03, lubricate with light machine oil the section of the shaft over which the seal is to be mounted. Slide the rotating element onto the shaft. Be sure it is properly positioned against the retaining ring. After checking the bearing cage and replacing, if required, coat the sealing surfaces with light machine oil. Install bearing cage and gasket and secure with cap screws.

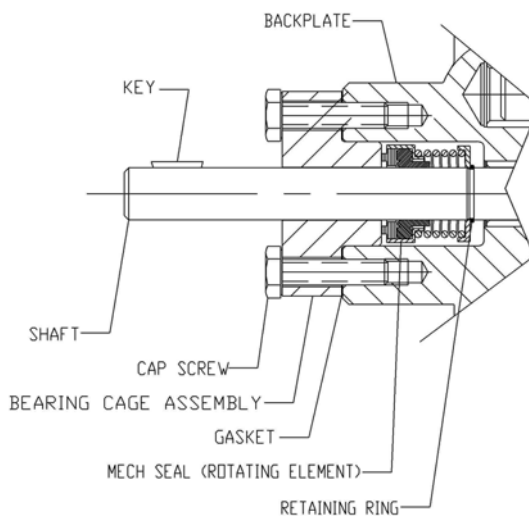

AM06-AM40

To reassemble the mechanical seal on pump sizes AM06 thru AM40, lubricate with light machine oil the section of the shaft over which the seal is to be mounted. Slide the locator ring over the shaft and back against the retaining ring. Slide the rotating element onto the shaft. Be sure it is properly positioned against the locator ring. After checking the stationary seal face and o-ring and replacing, if required, coat the sealing surface with light machine oil. Install stationary seal face and retainer plate and secure with cap screws.

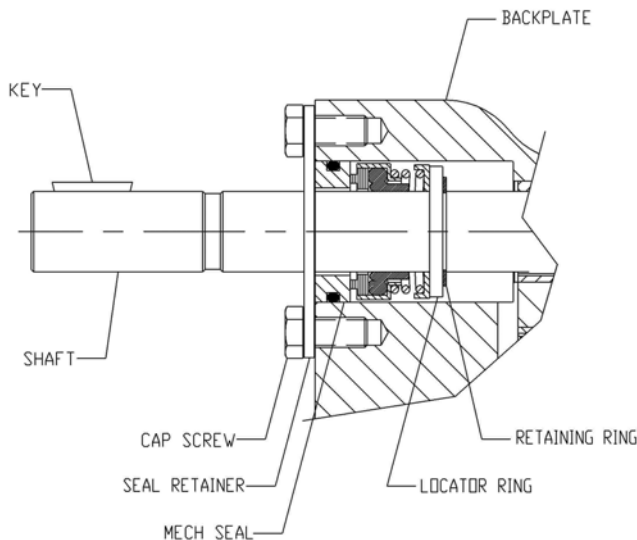

CHANGING FROM PACKED BOX TO MECHANICAL SEAL

When it is desirable to change from packed box to mechanical seal, remove the key, cap screws, packing plate, packing gland, packing rings and washer (AM06-AM40 only). The exposed surface of the shaft should be free from burrs and sharp edges. Clean the shaft and apply a film of light machine oil. Install the retaining ring. Refer above to install the seal.

LIP SEAL (AL) PUMPS

AL pumps with lip seals must be run in the clockwise direction of rotation only. Maximum discharge pressure is 100 PSIG (6.9 BAR) and maximum inlet pressure is 5 PSIG (3 BAR). For a pump equipped with a lip seal, follow these instructions. Leaking lip seals should be replaced. Note the direction of the lip on the old seal. Carefully pry the defective seal from the bore, making certain that the bore is not scored or damaged. Clean the shaft and bore. Inspect the shaft for wear. If worn or scored, replace. The exposed surface of the shaft should be free from burrs and sharp edges. Lightly oil shaft and bore into which the lip seal is to be fitted. Be careful not to damage the sealing lip and be certain that the lip on the new seal is turned the same direction as the old seal. Slide the seal onto the shaft and press into the bore.

PACKED BOX (AP) PUMPS

Operate the pump under normal conditions and, after a short run-in period, examine the packing for leakage. If leakage is excessive, stop the pump and follow the procedure described below. A slight leakage is a necessary and normal condition for packing and allows for expansion and proper seating.

SIZES 005 THRU 03

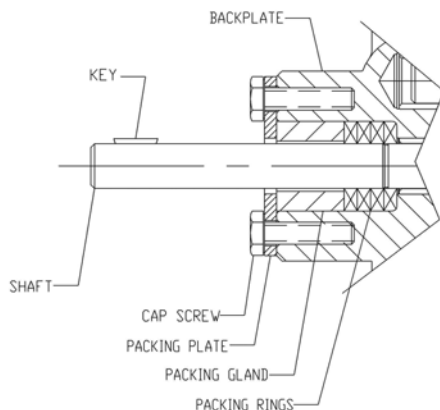

SIZES 06 THRU 40

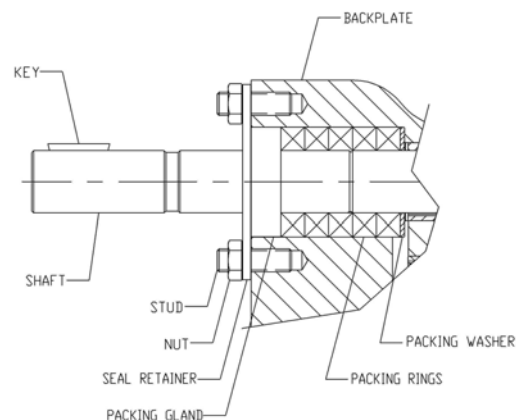

To replace packing, remove the key, cap screws or nuts, packing plate, packing gland, and packing rings. (Packing hooks are commercially available to assist in removing the packing rings.)

Clean the shaft and adjacent parts. Examine the shaft. If it is excessively worn or scored, replace shaft and gear assembly. It is generally not recommended to reuse old packing rings. When installing packing, use formed packing rings. DO NOT use a one-piece spiral wrap of packing. Before installing packing, carefully clean the stuffing box and shaft.

Packing rings should be installed one ring at a time, with the joints of adjacent rings staggered approximately 180°. Each ring should be seated firmly before the next ring is installed.

The packing gland cap screws or nuts should first be evenly tightened with a wrench to seat the packing firmly in the stuffing box and against the shaft. DO NOT over-tighten the packing. The gland cap screws or nuts should then be backed off until finger-tight. After the pump is started, visually examine the stuffing box for excessive leakage. If the packing leakage exceeds ten drops per minute, stop the pump and adjust the gland nuts. The gland cap screws or nuts should be adjusted evenly in 1/6 to 1/3 turn (1 to 2 flats on the nut) increments. Start the pump and allow it to operate for several minutes. Again, visually examine the stuffing box for excessive leakage. Repeat the above procedure until the stuffing box leakage is between five to ten drops per minute.

DO NOT over-tighten the packing. Slight leakage is a necessary requirement for proper packing operation. Leakage of five to ten drops per minute when the pump is operating is desirable, as it will preserve the packing and avoid scoring of the shaft. Over-tight packing may score shafts, increase torque requirements of the pump, damage couplings and drives, and generate excessive heat.

The packing gland should be adjusted whenever leakage exceeds ten drops per minute. The condition of the packing should be checked at regular intervals, the frequency depending on the type of service. Experience will dictate how frequently the inspections should be made.

THIS PAGE
INTENTIONALLY
LEFT BLANK