

## BULK FLUID DISPENSING PACKAGES

Complete bulk fluid dispensing packages with 140, 230 and 330 Gallon CUBET tanks. CUBET tanks are ULC listed and they are made from HD-8760 high density copolymer that offers the following advantages:

- Environmentally superior.
- Long term UV stabilization.
- 250 mil wall thickness.
- Level always visible, no gauge needed.
- No vent cap needed.
- Will not leak or rust, seamless construction.
- Space saving, conserves floor space.

CUBETS can accommodate oil, water based fluids and other chemicals. They are also available with a dual containment steel basket that holds 110% of the tank volume.



C 142.14

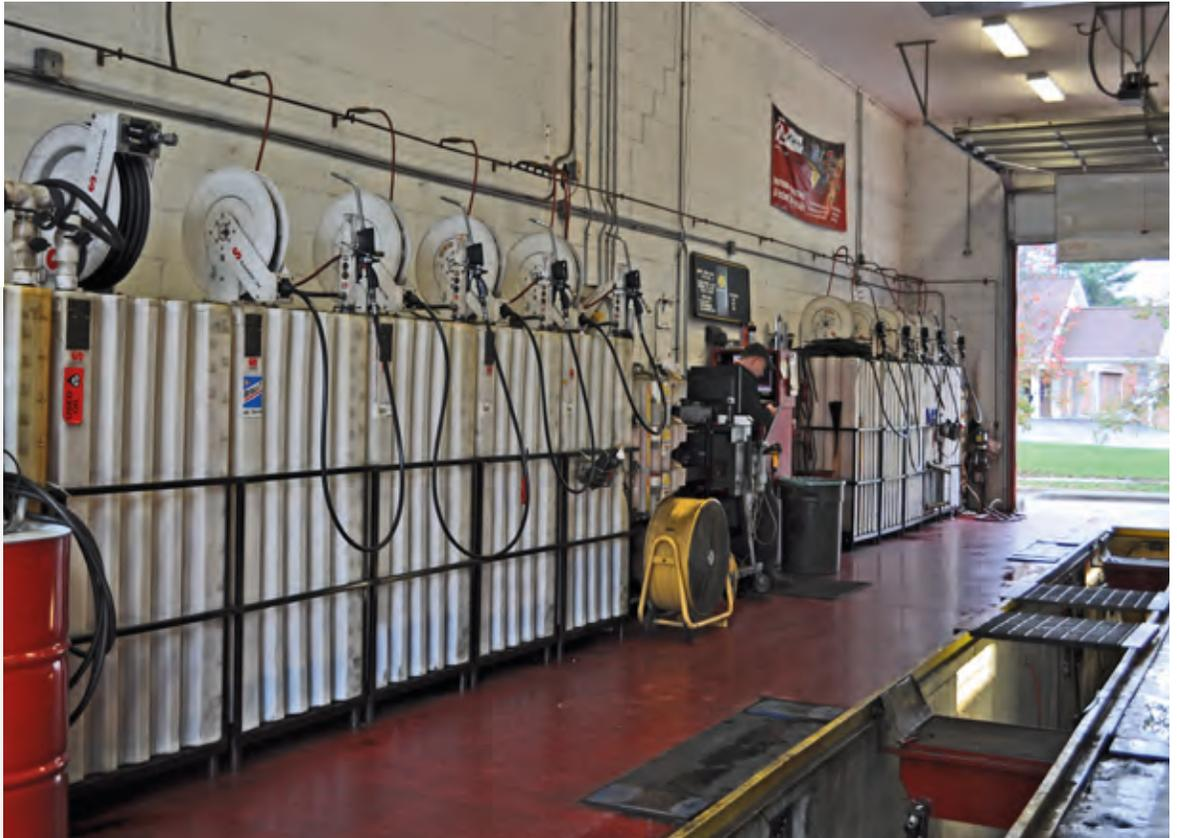

07

BULK  
PACKAGES

## 140 GAL PACKAGES



Dimensions

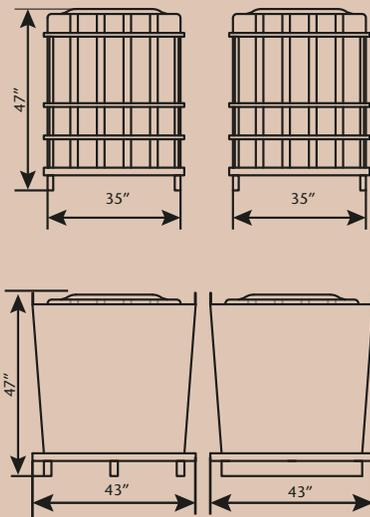

PART No.	DISPENSE HOSE	DISPENSE HANDLE	TANK TYPE	FLUIDS
<b>BARE TANKS</b>				
<b>3140</b>	140 gal tank - tank and cage only		Cage	ALL
<b>3140DC</b>	140 gal tank - tank and dc only		Dual containment	ALL
<b>PACKAGES FOR OIL WITH PM2 3:1 PUMP</b>				
<b>3214</b>	10' Hose 847	Metered handle 365 536	Cage	OILS
<b>3214DC</b>			Dual containment	OILS
<b>3216</b>	30' x 1/2" hose reel 506 202		Cage	OILS
<b>3216DC</b>			Dual containment	OILS
<b>PACKAGES FOR DEF WITH AIR-POWERED DIAPHRAGM PUMP 552 015</b>				
<b>550 004 140</b>	30' x 1/2" hose reel 506 702	Automatic nozzle 688 303	Cage	DEF
<b>PACKAGES FOR DEF WITH 110 V AC ELECTRIC DIAPHRAGM PUMP 560 215</b>				
<b>555 112 140</b>	30' x 1/2" hose reel 506 702	Automatic nozzle 688 303	Cage	DEF
<b>PACKAGES FOR WATER BASED FLUIDS WITH AIR-POWERED DIAPHRAGM PUMP 552 016</b>				
<b>3218</b>	10' Hose 824 2	Dispense handle 186 300	Cage	WWF/AF
<b>3218DC</b>			Dual containment	WWF/AF



## 230 GAL PACKAGES

Dimensions

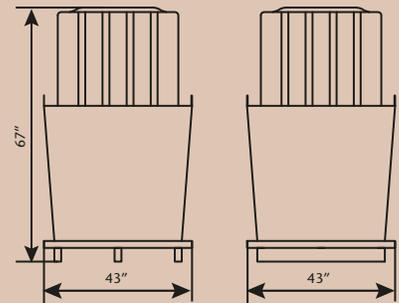
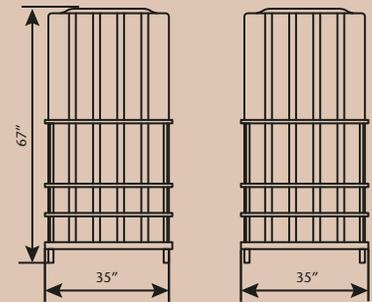

07  
BULK  
PACKAGES

PART No.	DISPENSE HOSE	DISPENSE HANDLE	TANK TYPE	FLUIDS
<b>BARE TANKS</b>				
<b>3223</b>	230 gal tank - tank and cage only		Cage	ALL
<b>3223DC</b>	230 gal tank - tank and DC only		Dual containment	ALL
<b>PACKAGES FOR OIL WITH PM2 3:1 PUMP</b>				
<b>3234</b>	10' Hose 847	Metered handle 365 536	Cage	OILS
<b>3234DC</b>			Dual containment	OILS
<b>3232</b>	30' x 1/2" Hose reel 506 702		Cage	OILS
<b>3232DC</b>			Dual containment	OILS
<b>3236</b>	50' x 1/2" Hose reel 506 722		Cage	OILS
<b>3236DC</b>			Dual containment	OILS
<b>PACKAGES FOR OIL WITH PM4 5:1 PUMP</b>				
<b>3238</b>	50' x 1/2" Hose reel 506 722	Metered handle 365 536	Cage	OILS
<b>3238DC</b>			Dual containment	OILS
<b>PACKAGES FOR DEF WITH AIR-POWERED DIAPHRAGM PUMP 552 164A</b>				
<b>550 004 230</b>	30' x 1/2" Hose reel 506 702	Automatic nozzle 688 303	Cage	DEF
<b>PACKAGES FOR DEF WITH 110 V AC ELECTRIC DIAPHRAGM PUMP 560 215</b>				
<b>555 112 230</b>	30' x 1/2" Hose reel 506 702	Automatic nozzle 688 303	Cage	DEF
<b>PACKAGES FOR WATER BASED FLUIDS WITH AIR-POWERED DIAPHRAGM PUMP 552 164</b>				
<b>3228R</b>	30' x 1/2" Hose reel 506 122	Dispense handle 186 300	Cage	WWF/AF
<b>3228RDC</b>			Dual containment	WWF/AF
<b>3228</b>	10' Hose 824 2		Cage	WWF/AF
<b>3228DC</b>			Dual containment	WWF/AF

## 330 GAL PACKAGES



Dimensions

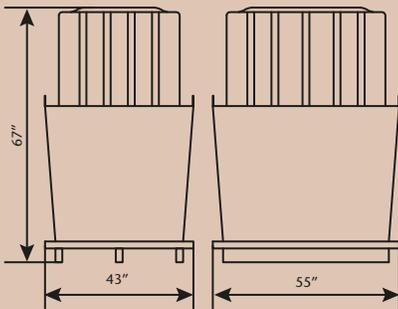
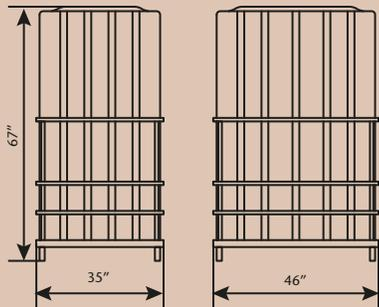

PART No.	DISPENSE HOSE	DISPENSE HANDLE	TANK TYPE	FLUIDS
<b>BARE TANKS</b>				
<b>3333</b>	330 gal bulk tank - tank and cage only		Cage	ALL
<b>3333DC</b>	330 gal bulk tank - tank and dc only		Dual containment	ALL
<b>PACKAGES FOR OIL WITH PM2 3:1 PUMP</b>				
<b>3334</b>	10' Hose 847	Metered handle 365 536	Cage	OILS
<b>3334DC</b>			Dual containment	OILS
<b>3332</b>	30' x 1/2" Hose reel 506 702		Cage	OILS
<b>3332DC</b>			Dual containment	OILS
<b>3336</b>	50' x 1/2" Hose reel 506 722		Cage	OILS
<b>3336DC</b>			Dual containment	OILS
<b>PACKAGES FOR OIL WITH PM4 5:1 PUMP</b>				
<b>3338</b>	50' x 1/2" Hose reel 506 722	Metered handle 365 536	Cage	OILS
<b>3338DC</b>			Dual containment	OILS
<b>PACKAGES FOR DEF WITH AIR-POWERED DIAPHRAGM PUMP 552 164A</b>				
<b>550 004 330</b>	30' x 1/2" hose reel 506 702	Automatic nozzle 688 303	Cage	DEF
<b>PACKAGES FOR DEF WITH 110 V AC ELECTRIC DIAPHRAGM PUMP 560 215</b>				
<b>555 112 330</b>	30' x 1/2" hose reel 506 702	Automatic nozzle 688 303	Cage	DEF
<b>PACKAGES FOR WATER BASED FLUIDS WITH AIR-POWERED DIAPHRAGM PUMP 552 164</b>				
<b>3328R</b>	30' x 1/2" hose reel 506 122	Dispense handle 186 300	Cage	WWF/AF
<b>3328RDC</b>			Dual containment	WWF/AF
<b>3328</b>	10' Hose 824 2		Cage	WWF/AF
<b>3328DC</b>			Dual containment	WWF/AF