



INSTALLATION MANUAL

WORKTOP MODEL 8867

ATTENTION: PLEASE READ AND UNDERSTAND ALL INSTRUCTIONS AND WARNINGS BEFORE ASSEMBLING, INSTALLING OR USING THIS PRODUCT.



WARNING

These instructions are to be followed using the parts and fasteners supplied for proper installation. Any modifications or improper installation of this product will create a hazardous condition that can cause property damage, serious personal injury or death.

– NOTICE –

Any modification or unintended use of this product shall immediately void all manufacturers warranties. Manufacturer disclaims all liability for injuries to persons or property resulting from any modification to, or unintended use of this product.

Approximate Assembly and Installation Time:

20 min. (.3 hours) depending on van equipment installation experience.

PARTS

| Item | Qty. | Description |
|------|------|-------------------|
| A | 1 | Work Top |
| | 1 | Bolt Kit #32-0101 |

TOOLS REQUIRED

- Electric Drill
- Drill Bits: 13/32", 1/8"
- Open End Wrenches: 7/16", 9/16"

1 NOTE: The unit(s) this work top is to be mounted on, must be the correct width or properly spaced to accept the mounting method.

Place the Work Top in position and mark the center point of the bolt holes that will require fastening.



NOTE: Mark center of bolt hole carefully since an off-center Blind Fastener makes installation difficult.

Remove work top and drill where marked with 1/8" drill bit for pilot holes. Redrill holes to enlarge them, using a 13/32" drill bit. Install Blind Fasteners. (See INSTALLATION INSTRUCTIONS FOR BLIND FASTENERS on page 2).

Attach Work Top using four (4) 1/4-20 x 3/4" Hex Head Bolts and 1/4" Lock Washers.

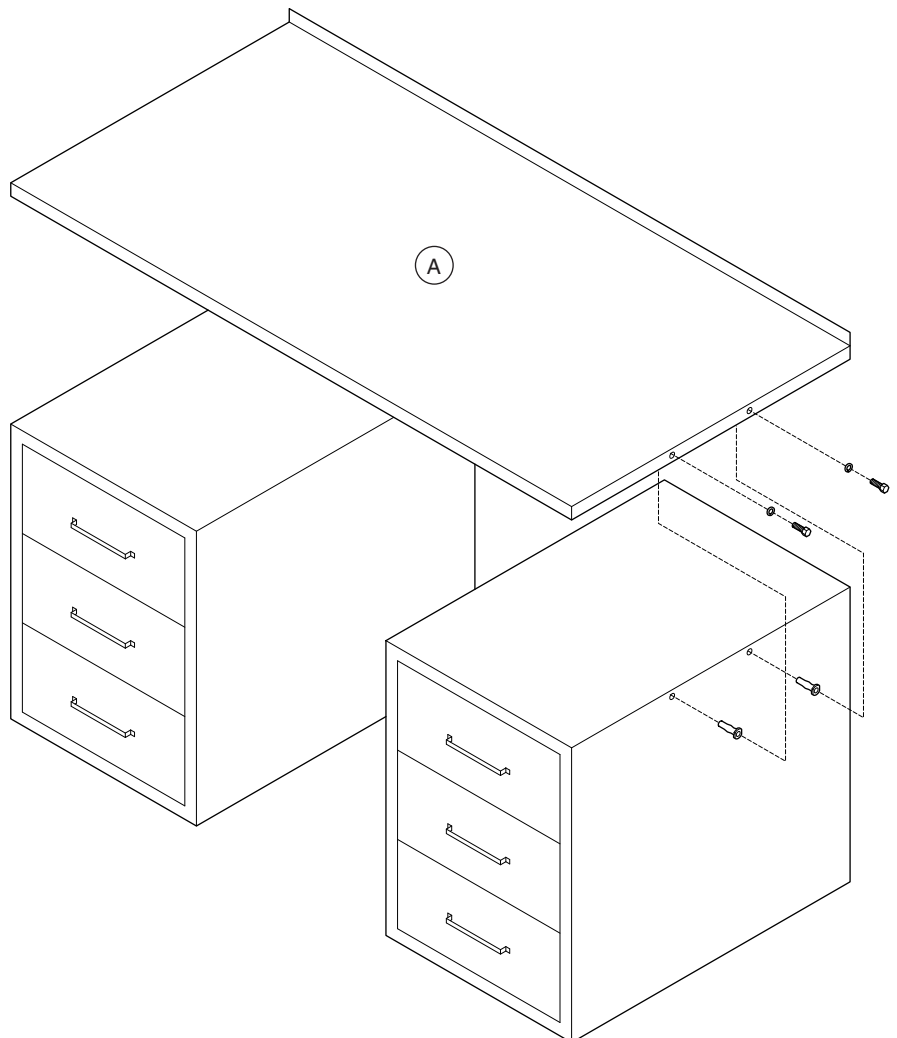
INSTALLATION IS NOW COMPLETE.

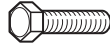

-  4 1/4-20 Blind Fasteners
-  4 1/4" Lock Washers
-  4 1/4-20 x 3/4" Hex Head Bolts

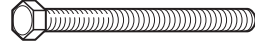
-  1 Blind Fastener Installation Tool
-  1 1/4-20 x 2-1/4" Hex Head Black Bolt

! CAUTION

INSTALLATION INSTRUCTIONS FOR BLIND FASTENERS

To keep debris out of your eyes when drilling, always wear protective eyewear.

Place a drop of oil on the black oxide bolt before assembling as shown on right. Place the Blind Fastener in the hole and use a 7/16" wrench to tighten black hex bolt until the Blind Fastener is fully seated. When setting black hex bolt, it will start out hard. As the Blind Fastener "bulbs" out it will get easier, until it bottoms out or sets. Make sure the Blind Fastener and Installation Tool do not turn during installation.

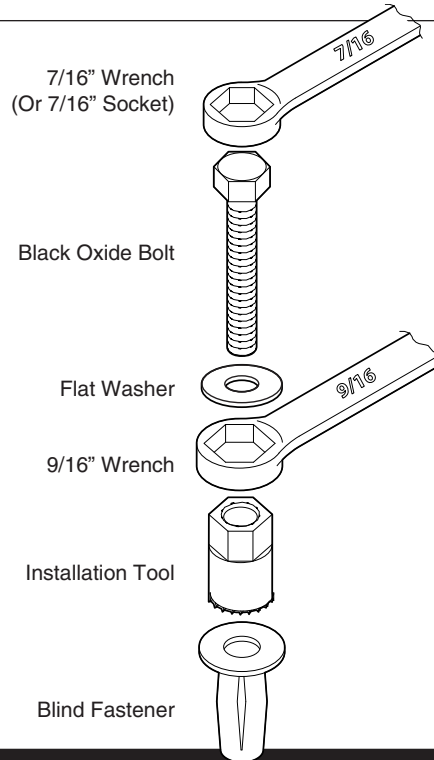

KNAACK LLC LIMITED WARRANTY

This LIMITED WARRANTY is made by Knaack ŠŠÖ. 420 E. Terra Cotta Ave., Crystal Lake, Illinois to the original retail purchaser of KNAACK® Products.

KNAACK LLC WARRANTS THAT KNAACK PRODUCTS WILL BE FREE FROM DEFECTS IN MATERIAL AND WORKMANSHIP FOR A PERIOD OF THREE (3) YEARS FROM DATE OF PURCHASE BY THE ORIGINAL RETAIL PURCHASER.

If, before the expiration of the Warranty period, purchaser discovers that the KNAACK Product fails to fulfill the Warranty, purchaser shall contact Knaack LLC to make arrangements for an inspection of the product. If Knaack LLC determines a defect exists, Knaack LLC shall, at its option and expense, repair or replace any defective part. All Warranty repairs shall be made by an authorized KNAACK Product dealer or Knaack LLC approved service company.

This Warranty shall not apply if the KNAACK Product has been subjected to misuse, abnormal service or handling, improper maintenance, or alterations made by anyone other than a KNAACK Product dealer or a Knaack LLC approved service company.

THE WARRANTY PRINTED ABOVE IS THE ONLY WARRANTY APPLICABLE TO THIS PURCHASE. ALL OTHER WARRANTIES, EXPRESS OR IMPLIED, INCLUDING BUT NOT LIMITED TO THE IMPLIED WARRANTIES OF MERCHANTABILITY AND FITNESS FOR A PARTICULAR PURPOSE ARE HEREBY DISCLAIMED.

KNAACK LLC. SHALL NOT BE LIABLE FOR ANY INCIDENTAL OR CONSEQUENTIAL DAMAGES ARISING OUT OF ANY BREACH OF THIS WARRANTY. NOR SHALL THE DAMAGES EXCEED THE RETURN AMOUNT OF THE PURCHASE PRICE PAID BY THE ORIGINAL PURCHASER.

This Warranty is in lieu of all Warranties express or implied. The terms of this Warranty shall not be modified by any party, their successors or assigns. This Warranty gives you specific legal rights, and you may also have other rights which vary from state to state.