

Defender Series™ Spill Containers

Defender Series™ five gallon spill containers combine years of knowledge and experience in forecourts across the globe to represent the next generation in spill containment. The Defender Series™ adapts alongside evolving environmental regulations with the latest innovations in spill containment. Get the best defense and quality construction with the Defender Series™.

Electronic
Liquid
Detection
Sensor Option



I2 Interstitial
Integrity
Monitor
Mechanical
Liquid Detection
Sensor



Variable
Height
Adjustable



Highlights

Fugitive Emission Protection

Proactively protecting a site from the dangers of fugitive emissions can save station owners both time and money by avoiding remediation due to fuel leakage. The Defender Series provides several key defenses from these costly expenses:

- 1 1/4" compression gasket provides a vapor tight mechanical seal.
- Drop tube compression adapter ensures a vapor tight seal.
- Drain valve designed to meet CARB leak rate requirements.
- Concentrated secondary containment catch basin provides immediate notification of integrity breach

Integrity Confirmation

Always know how your spill containment is performing and get immediate confirmation on the integrity of the interstitial space with the following Defender Series features:

- I² (Interstitial Integrity) Monitor facilitates efficient monthly and annual visual inspections confirming the integrity of the secondary containment space.
- Electronic liquid detection sensor option available with proven INCON™ brand TSP-ULS (Universal Liquid Sensor) for active leak detection.
- TSP-ULS wiring penetrates side wall of gravel guard ensuring no additional installation height requirement.

Minimized Maintenance Costs

Maximize your business' value and minimize installation and maintenance expenses with features like:

- Field replaceable containment – replace easily without having to break concrete, simply loosen the four plow ring bolts to remove and replace interior containment.
- Plow ring bolts are protected – located inside the interior of the container, shielding them from the potential wear and tear of the forecourt environment.
- Variable height adjustments – allows for an installation height between 14 1/2" and 17 5/8", for easy installation in retrofit applications.

Variable Installation Height

The Defender Series™ double wall and single wall field replaceable spill container was designed with the retrofit application in mind. The variable height adjustment feature allows an installation height range of 14 1/2" to 17 5/8" which minimizes the number of retrofit spill containment options needed to replace existing direct bury containments. This reduces the need to replace tank risers and ultimately reduces the retrofit installation time.

Variable Installation Height

As regulations change, it may become necessary to upgrade a single wall spill container to meet future requirements. The Defender Series™ spill container allows the single wall option to be converted into a double wall spill container simply by removing the snow plow ring, removing the single wall containment, threading the secondary contained spill container onto the existing tank riser and then reinstalling the snow plow ring.

Specifications

- Exceeds H20 and HS20 load standards (maximum axle load requiring support for the 32,000 or 16,000 pounds for each set of dual tire wheels).

Approvals

- ULC listed.
- CARB approved.

Ordering Information

Ordering Guide

Complete spill container part numbers have a specific order and are created using the following guidelines:

705 XXX YAB CI-GKT

XXX = Containment Options

- 545 = Single wall
- 555 = Double wall

Y = Interstitial Monitoring Options

- 0 = No sensor
- 1 = I² Monitor (float gauge)
- 2 = TSP-ULS Sensor

A = Base Thread Options

- 0 = NPSM
- 1 = NPT
- 2 = BSPT

B = Drain Options

- 1 = With Drain
- 2 = Without Drain

CI-GKT = Lid

CI-GKT is a standard gray epoxy-coated cast iron gasketed lid. Call factory for additional lid options.

Example: 705555111CI-GKT = Double wall Defender Series™ spill container with I² monitor, with NPT base thread, with drain and with standard cast iron gasketed lid.

Defender Series™ Spill Containers

Model	Description
705545001CI-GKT	Defender Series™ 5 gallon spill container, single wall, NPSM thread, with drain, with gray epoxy-coated cast iron gasketed lid
705545002CI-GKT	Defender Series™ 5 gallon spill container, single wall, NPSM thread, without drain, with gray epoxy-coated cast iron gasketed lid
705555101CI-GKT	Defender Series™ 5 gallon spill container, double wall, NPSM thread, with drain, with I ² monitor, with gray epoxy-coated cast iron gasketed lid
705555102CIOGKT	Defender Series™ 5 gallon spill container, double wall, NPSM thread, without drain, with I ² monitor, with gray epoxy-coated cast iron gasketed lid
705555201CIOGKT	Defender Series™ 5 gallon spill container, double wall, NPSM thread, with drain, with TSP-ULS sensor, with gray epoxy-coated cast iron gasketed lid
705555202CI-GKT	Defender Series™ 5 gallon spill container, NPSM thread, without drain, with TSP-ULS sensor, with gray epoxy-coated cast iron gasketed lid
705559901*	Defender Series™ spill container cutaway display, double wall, with drain, with I ² monitor

*For display and demonstration purposes only. Six-to-eight week lead time.

Ordering Information continued

Defender Series™ Spill Container Replacement Parts

#	Model	Description
1	70550301	Spill container seal-ring
2	602256001	Tank riser gasket
3	1103939	DT riser clamp O-ring
4	70551101	I ² monitor
5	70551002	Inspection port (I ² monitor)
6	70551001	Inspection port (sensor)
7	70550901EC	DT riser clamp
8	70533729	Pull to push drain valve kit
9	70553001	Snow plow ring assembly
10	70544011	Cover, cast iron w/ gasket (gray)
11	1115601	Slotted hex head self-tapping screw
	70553101	Drain chain an clip
N/A	705552101	BKT ASM, DW, AGB, I2, DRN, NPSM
N/A	705552102	BKT ASM, DW, AGB, I2, ND, NPSM
N/A	705552201	BKT ASM, DW, AGB, SEN, DRN, NPSM
N/A	705552202	BKT ASM, DW, AGB, SEN, ND, NPSM

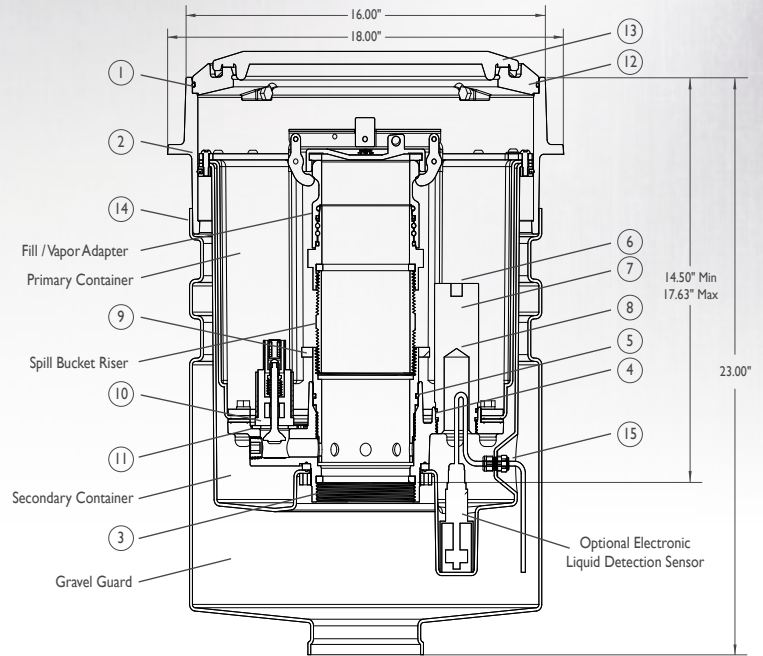

Defender Series™ Spill Container Installation Tools

Model	Description
T-7001	T-handle wrench
T-7106	Double-ended installation tool
T-7107	Double wall vacuum test kit (for double wall models only)



A Franklin Fueling Systems Brand

franklinfueling.com

3760 Marsh Rd. • Madison, WI 53718, USA
 Tel: +1 608 838 8786 • Fax: +1 608 838 6433
 Tel: USA & Canada +1 800 225 9787 • Tel: UK +44 (0)1473 243300
 Tel: Mex 001 800 738 7610 • Tel: FR +33 (0)1 69 21 41 41 • Tel: CH +86 10 8565 4566

