



API 676 Compliant Positive Displacement Rotary Lobe Pumps

L133

SPECIFICATIONS	US	Metric
Rated Capacity:	0-665 gpm	0-151 m ³ /h
Displacement (per 100 revolutions):	133 gal (US)	501 L
Maximum Continuous Pressure:	125 psi	8.6 bar
Starting Torque:	2,860 in lbf	323 N m
Rated Speed:	0-500 RPM**	0-600 RPM
Shaft Diameter:	2.4"	60 mm
Flange Connection Class:	ANSI 16.5-150#	DN – PN 10
Flange Connection Size:	ANSI 6"	DN 150
Weight:	507 lbs	230 kg
Solids Handling		
Spherical Compressible	3"	76 mm
Spherical Hard*	1/8"	3 mm
NPSH required:	3 ft.	1 m

* Larger hard solids will pass through but may cause damage.

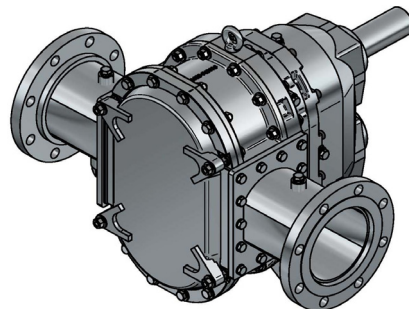

MODEL >	API-SL133	API-CL133	API-DL133
Service	Non-Corrosive Sludge & Slurries	Chemical/Corrosive	Oil, Gas, Abrasive and Corrosive
WETTED PARTS			
Rotary Lobes			
Elastomer Options	NBR, Opt. FKM, HNBR, EPDM or Eng. Rec.	HNBR, Opt. FKM, NBR, EPDM or Eng. Rec.	HNBR, Opt. FKM, NBR, EPDM or Eng. Rec.
Lobe Profile	Helix	Helix	Helix
Number of lobe wings	4	4	4
Core	Carbon Steel	Carbon Steel	Carbon Steel
Sealing Elastomers			
O-rings	FKM	FKM or Engineer Recommendation	FKM or Engineer Recommendation
Lip seals	FKM or Engineer Recommendation	FKM or Engineer Recommendation	FKM or Engineer Recommendation
Shaft Seal / Mechanical Seals*			
Type	Single Mechanical Cartridge	Single Mechanical Cartridge	Single Mechanical Cartridge
Flushing	Internal Oil Cooled.	Internal Oil Cooled.	Internal Oil Cooled.
Seal Faces	Duronit, Opt. Silicon Carbide or Tungsten Carbide	Silicon Carbide, Opt. Tungsten Carbide	Silicon Carbide, Opt. Tungsten Carbide
Seal Holders	Carbon Steel with Corrosion resistant coating	316 Stainless Steel	2205 Duplex
Seal Inspection & Removal	May be accomplished without removing driver	May be accomplished without removing driver	May be accomplished without removing driver
Wear Plates	AR500 Steel (Brinell 500)	Duplex Stainless Steel	Duplex Stainless Steel
Housing Segments			
	Duplex CD3Mn Stainless Steel	Duplex CD3Mn Stainless Steel	Duplex CD3Mn Stainless Steel
Flange:			
	Carbon Steel	316 Stainless Steel	Duplex Stainless Steel
Bolts			
	316 SS Hex Head DIN 933	316 SS Hex Head DIN 933	Duplex SS Hex Head DIN 933
Bolts- Strain Bolt			
	Alloy Steel Socket Head DIN 912/ISO 4762	316 SS Socket Head DIN 912/ISO 4762, A2-A4	Duplex SS Socket Head DIN 912/ISO 4762
Pressure Disc			
	Stainless Steel Type 316L	Stainless Steel Type 316L	Duplex Stainless Steel
LIMITED EXPOSURE PARTS			
Pump Cover			
	Carbon Steel or ASTM A48 Grey Iron	Carbon Steel or ASTM A48 Grey Iron	Carbon Steel or ASTM A48 Grey Iron
Quench/Seal Cooling Chamber			
	ASTM Grey Iron Rust Primed.	SSPC-SP6 Sandblast/Paint Opt. 316L SS Cover ASTM Grey Iron SSPC-SP6 Sandblast/Paint with PTFE / Ceramic Teflon etched on face	SSPC-SP6 Sandblast/Paint Opt. Duplex SS Cover ASTM Grey Iron SSPC-SP6 Sandblast/Paint with PTFE / Ceramic Teflon etched on face
NON-WETTED PARTS			
Timing Gears			
	AGMA Class 9 SAE 1045 steel	AGMA Class 9 SAE 1045 steel	AGMA Class 9 SAE 1045 steel
Gear Housing			
	ASTM A48 Grey Iron rust primed	ASTM A48 Grey Iron SSPC-SP6 Sandblast/Paint	ASTM A48 Grey Iron SSPC-SP6 Sandblast/Paint
Shaft			
	AISI 4140 Alloy Steel	AISI 4140 Alloy Steel	AISI 4140 Alloy Steel
Shaft Keyways			
	Fillet radii conforming to ASME B17.2	Fillet radii conforming to ASME B17.2	Fillet radii conforming to ASME B17.2
Bearings			
	K5 Fit, C3 internal Clearance per AGMA7	K5 Fit, C3 internal Clearance per AGMA7	K5 Fit, C3 internal Clearance per AGMA7
OTHER INFORMATION			
Welding			
	Operators qualified under ASME BPVC Section IX	Operators qualified under ASME BPVC Section IX	Operators qualified under ASME BPVC Section IX
Draining and Venting			
	Partially Drain capable. External venting required	Partially Drain capable. External venting required	Partially Drain capable. External venting required
Flammable/Hazardous Service			
	ATEX II 3G/D T3	ATEX II 3G/D T3	ATEX II 3G/D T3
NOTE: Summary of the principal features of the LobePro API 676 compliant pump. There are many other provisions of API 676 which apply to the pump. Our API series pumps comply with all of these provisions.			
*: Our mechanical seals do not comply with API-682 due to the space and design parameters of the pump. However, our seal is not an exception and is considered an "Engineered Seal" under API 676 Revision 4. Flushing with pumped fluid (sludge/slurry) not desirable. Optional Plan 99 Oil Flush System available.			

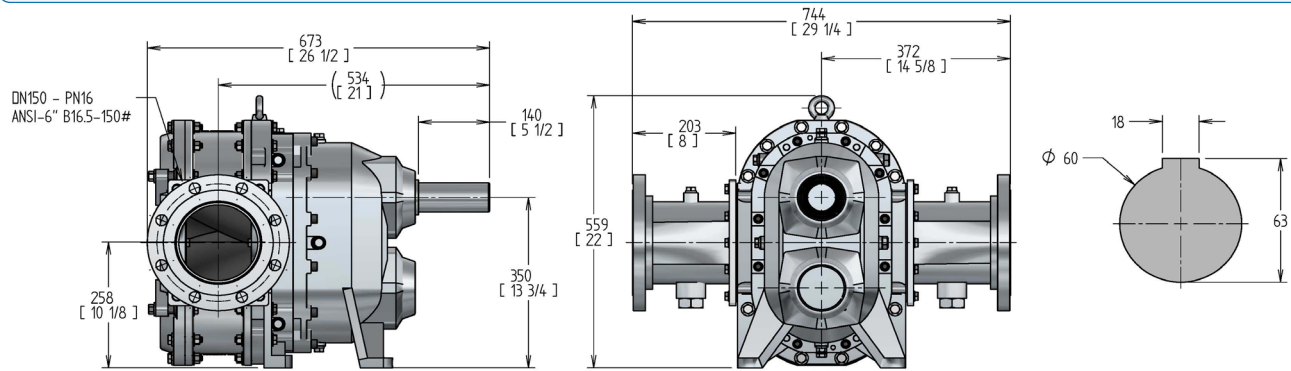

Section 35-40

16 April 2018

MODEL >

API-SL133, API-CL133, API-DL133

Standard Tests

Test Description

Hydrostatic Test

Operates without leaking at 150% of MACP when hydro tested

Run Test

Tested to determine if the pump operates without excessive vibration or seal leaks throughout operating range.

Performance Test

Tested at duty point to confirm pump curve.

Sound Test

Shall be under 85 db's at a distance of 3 ft. (1 meter).

Documentation Included

IOM section with material certifications, test data and results, record of heat treatments, results of quality control tests, and other data as agreed with Purchaser

L133 CURVES

Performance Curve - NBR Lobes*

Based on 70°F (21°C) fresh water (1 cp) at Sea Level.
Output will increase as viscosity of the fluid increases from 1.

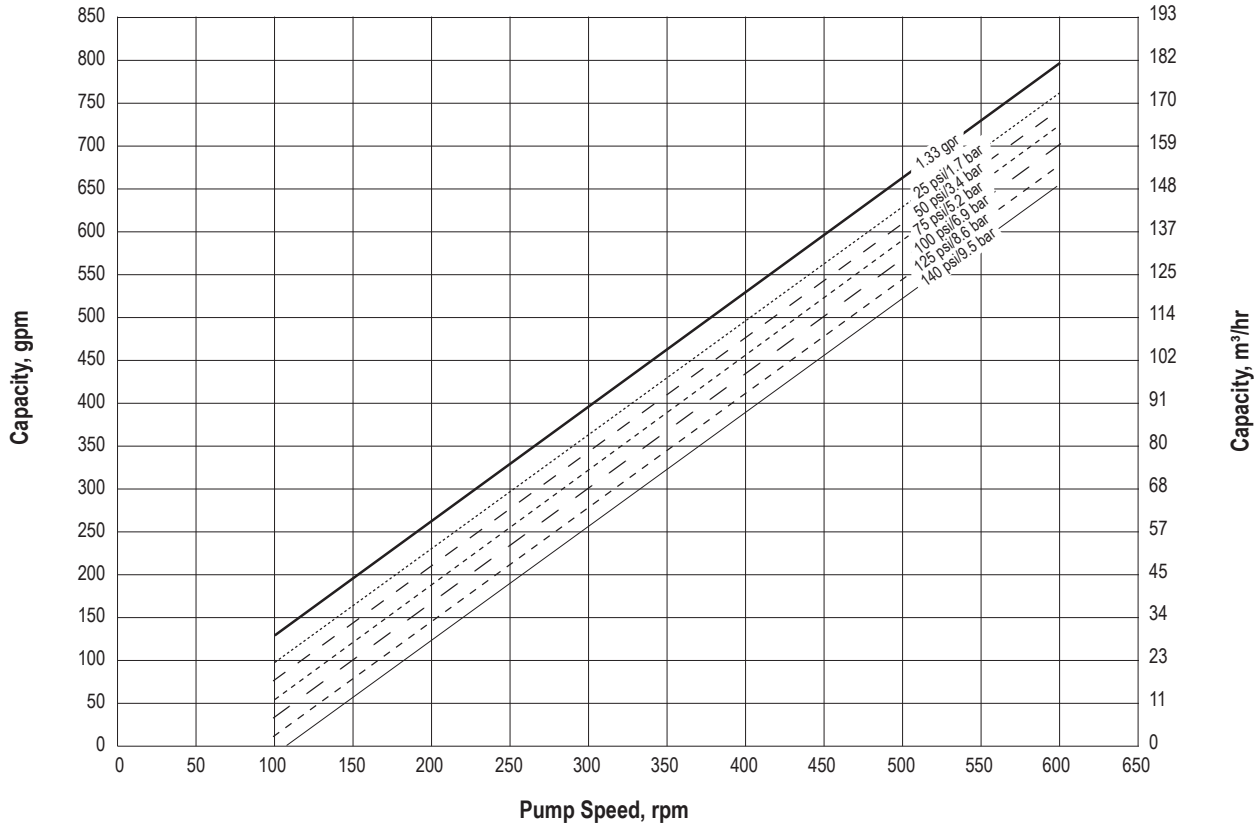

*Note: Output from lobes coated with elastomers other than NBR maybe lower. Contact Engineering for further information.

Horsepower Requirements

