

Positive Displacement Rotary Lobe Pumps

SPECIFICATIONS	US	Metric
Rated Capacity:	0-144 gpm	0-32 m ³ /hr
Displacement (per 100 revolutions):	16 gal (US)	60 L
Maximum Continuous Pressure:	100 psi	6.9 bar
Starting Torque:	720 in lbf	127 N m
Rated Speed:	0-900 RPM	0-900 RPM
Shaft Diameter:	1.1"	28 mm
Flange Connection Class:	ANSI 16.5-150#	DN - PN 16
Flange Connection Size:	ANSI 3"	DN 80
Weight:	175 lbs	80 kg
Solids Handling:		
Spherical Compressible	0.75"	19 mm
Spherical Hard*	1/8"	3 mm

* Larger hard solids will pass through but may cause damage.

MODEL >	SS16p	CS16p	DS16p
Service	Sludge, Mud and Slurries*	Chemical/Corrosive	Oil, Gas & Abrasives
WETTED PARTS			
Rotary Lobes			
Elastomer	NBR Opt. HNBR, FKM, EPDM or Eng. Rec.	FKM or HNBR Opt. NBR, EPDM or Eng. Rec.	FKM or HNBR Opt. NBR, EPDM or Eng. Rec.
Lobe Profile	Helix	Helix	Helix
Number of lobe wings	6	6	6
Core	Carbon Steel	Carbon Steel	Carbon Steel
Sealing Elastomers			
O-rings	FKM	FKM or Engineer Recommendation	FKM or Engineer Recommendation
Lip seals	FKM or Engineer Recommendation	FKM or Engineer Recommendation	FKM or Engineer Recommendation
Mechanical Seals			
Mechanical Seal	Duronit Opt. Tungsten Carbide, Silicon Carbide or Eng. Rec.	Silicon Carbide Opt. Tungsten Carbide or Engineer Rec.	Silicon Carbide Opt. Tungsten Carbide or Engineer Rec.
Seal Holders	Carbon Steel with Corrosion resistant coating	Stainless Steel Type 316	Duplex Stainless Steel
Wear Plates			
Wear Plates	AR500 Steel (Brinell 500)	Duplex Stainless Steel	Duplex Stainless Steel
Pump Wetend Housing			
Proform design**	ASTM A48 Grey Iron	Duplex CD3Mn Stainless Steel	Duplex CD3Mn Stainless Steel
Bolts			
Bolts	Carbon Steel ISO 898-I	Stainless Steel A2-A4	Duplex Stainless Steel
Pressure Disc			
Pressure Disc	Stainless Steel Type 316L	Stainless Steel Type 316L	Duplex Stainless Steel
LIMITED EXPOSURE PARTS			
Pump Cover	Carbon Steel Opt. Engineering Recommendation	Carbon Steel Opt. 316 Stainless Steel	Carbon Steel Opt. Duplex Stainless Steel
NON-WETTED PARTS			
Quench /Seal Cooling Chamber	Carbon Steel	Carbon Steel	Carbon Steel
Gears	GMA Class 9 AISI 1045 steel	GMA Class 9 AISI 1045 steel	GMA Class 9 AISI 1045 steel
Gear Housing	Carbon Steel or ASTM A48 Grey Iron rust primed	Carbon Steel or ASTM A48 Grey Iron	Carbon Steel or ASTM A48 Grey Iron
Shaft	AISI 4140 Alloy Steel	AISI 4140 Alloy Steel	AISI 4140 Alloy Steel
PAINTING REQUIREMENTS			
Standard Painting	SSPC/SP6 Sandblast Paint LobePro Blue	SSPC/SP6 Sandblast Paint LobePro Silver	SSPC/SP6 Sandblast Paint LobePro Silver

NOTE: Listed above are standard pump assemblies; lobe styles and materials subject to recommendation by LobePro Engineering. A wide range of optional materials are available for each model. Consult LobePro for further information. *Consult Factory for application temperature above 80°C (175°F). **Proform housing segment incorporates housing segment, flange ring, barrier plate and integral suction and discharge flange fittings in one piece. Component Design available in Sc line.

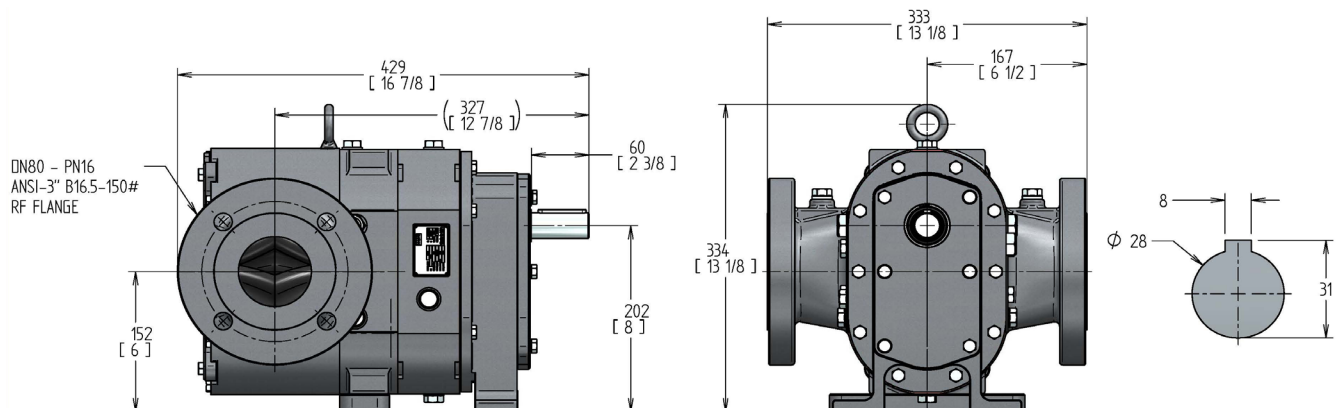

S16 CURVES

Performance Curve - NBR Lobes*
Based on 70°F (21°C) fresh water (1 cp) at Sea Level.
Output will increase as viscosity of the fluid increases from 1.

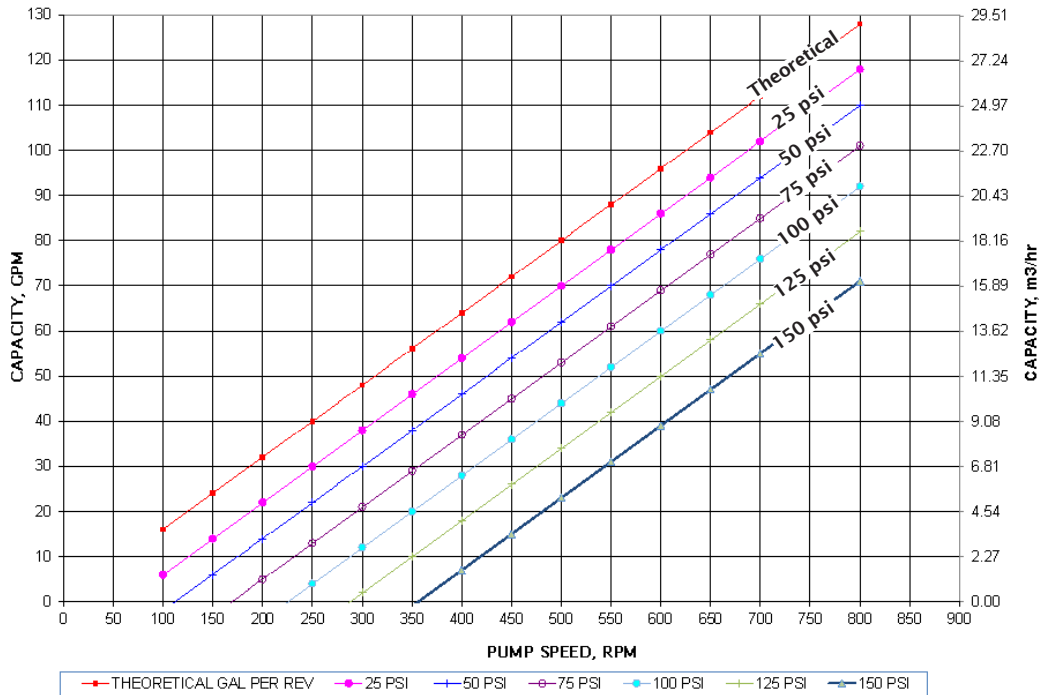

*Note: Output from lobes coated with elastomers other than NBR maybe lower. Contact Engineering for further information.

Horsepower Requirements

