

Model 711NC Solenoid Valve (Normally Closed)

SPECIFICATION SHEET

Application

The 711NC solenoid valve is a high flow pilot operated piston valve that is “normally closed.” This general purpose valve is for applications such as pressure systems, machine tools, water processing, and steam applications. The valve opens upon the receipt of an electronic signal such as when a dispenser or pump is switched to the on position.

Features and Details

- 7.5 PSI pressure differential required to keep the valve open
- Explosion and weather proof coil and housing
- 120V/60HZ standard, several optional coil voltages available
- Must be installed in a horizontal pipeline with the coil in the upright and vertical position
- Recommended for use with liquids having a maximum viscosity of 60 centistokes
- A strainer with a 100 mesh screen is recommended at the valve inlet

Materials of Construction

- Body and cover... Forged brass
- Seals...FKM

Code Compliance

UL listed



Item Number	Size (NPT)	Seal Material	Orifice Size (inches)	CV	Operating Pressure Differential MAX. (P.S.I.)		Fluid Temp.	Power Consumption (Watt) (Deg. F)	Weight (lbs.)	Gen. Dimensions (inches)			
					Min.	Max.				A	B	C	D
711NC-0075 1V	¾"	FKM	¾"	5.9	7.5	225	311	13	2.60	2.8	4.09	1.02	3.31
711NC-0100 1V	1"	FKM	1"	13	7.5	225	311	13	3.75	3.78	4.25	1.18	4.09
711NC-0150 1V	1½"	FKM	1½"	29	7.5	225	311	13	6.75	4.49	4.69	1.42	4.80
711NC-0200 1V	2"	FKM	2"	47	7.5	225	311	13	9.47	5.04	4.92	1.73	5.43

* Contact Morrison Customer Service for features and options not shown.

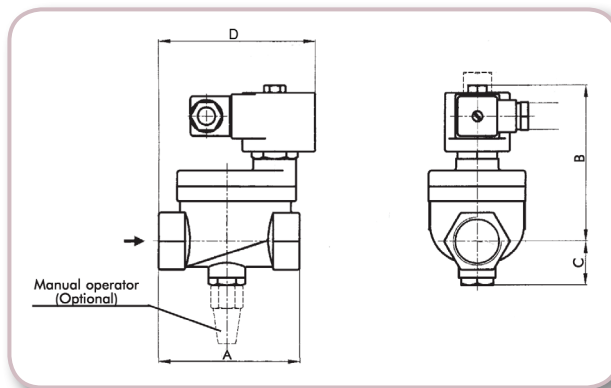

570 E. 7th Street, P.O. Box 238 | Dubuque, IA 52004-0238
t. 563.583.5701 | 800.553.4840 | f. 563.583.5028

www.morbros.com