

Fig. 434 Dispenser Pedestal

Installation & Maintenance Instructions

The Fig. 434 Series Dispenser Pedestals are designed to provide above grade secondary containment for plumbing and piping connections located beneath the dispenser. They also provide access to those connections for future service and maintenance.



Failure to follow any or all of the warnings and instructions in this document could result in a hazardous liquid spill, which could result in property damage, environmental contamination, fire, explosion, serious injury or death.

Installation



WARNINGS

- **Fire Hazard** – Death or serious injury could result from spilled liquids or vapors that catch fire or cause an explosion.
- Fuel and vapors from fuel may be present in and all around work area. Make certain that all electric power is disabled. Only use power tools with explosion proof ratings. Avoid sparks, open flames, or hot tools when working on, in, or around the pedestal.
- Install in accordance with all applicable local, state, federal laws.
- For your safety, it is important to follow local, state, federal and/or OSHA rules that apply to working inside, above, or around the pedestal area. Use all personal protective equipment required for working in the specific environment.
- Tanks or piping could be under pressure. Vapors could be expelled from tank vents, piping, valves or fittings while performing installation; Vapors could catch fire or cause an explosion. Avoid sparks, open flame, or hot tools when on working pedestal and components.

*****Bollards are required to protect dispenser pedestal and dispenser.*****

Steps for Anchoring Fig. 434

1. Inspect Fig.434 and included components for any shipping damage. Do not use any parts if damage is found.
2. Select desired location.
3. Drill holes in concrete and insert anchor bolts into concrete that are aligned with the 3/4 dia. mounting holes on the pedestal. (see Fig.1)
4. Remove pedestal top (see Fig.2) for ease of plumbing. Do not lose any hardware or damage pedestal top.
5. Place Fig.434 over anchor bolts and secure it to the concrete (see Fig.2) using suitable nuts and washers on the anchor bolts.

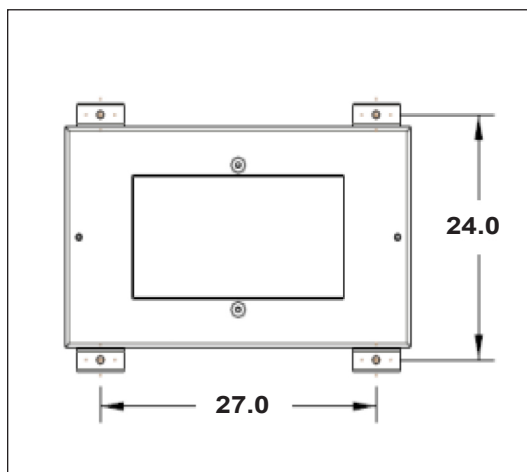

Figure 1

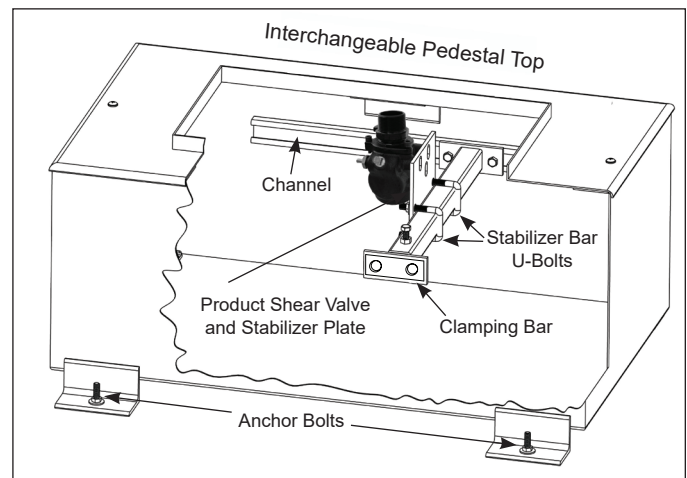

Figure 2

Steps for Piping to Fig. 434 Using Penetration Boots

1. Install all piping and entry boots per the boot manufacturer's specifications.

Application	Morrison Bros. Co. Part Number	Boot Size	Recommended Hole Size
¾" rigid conduit	434CB-0075 1B	¾"	2"
1" rigid conduit	434CB-0100 1B	1"	2"
1½" steel pipe	434CB-0150 1B	1½"	3½"
2" FRP and steel pipe	434CB-0200 1B	2"	3½"

Table 1 Boot Sizes

NOTICE: All openings for piping entering, or crossing, the walls of the Fig. 434 should be completed by following all applicable codes.

2. Use a hole saw, or similar tool, to make the desired entry boot holes.

WARNING: If using power tools in the presence of fuel, or fuel vapors, make certain the tools have an explosion proof rating.

3. If using Morrison Fig. 434CB connection boots, lightly sand 1.5" around the cut holes, on the outside of the pedestal wall, to rough up the surface. Clean this area.

4. Remove the hose clamp and threaded tightening ring from the Fig. 434CB.

5. Apply Morrison Fig. 434DBB bondor to the ribbed sealing surface of the Fig. 434CB. (see Fig.3)

6. Install Fig. 434CB through the hole, with the threaded portion protruding inside.

7. Thread the tightening ring onto the connection boot and tighten sufficiently.

8. Put hose clamp on the connection boot and run piping through the boot.

Do not tighten the hose clamp until all piping work is complete.



Figure 3

Steps for Piping to Fig. 434 with Threaded Connections

1. Follow standard threaded piping practices when connecting to the Fig. 434 with threaded connections.

NOTICE: All openings for piping entering, or crossing, the walls of the Fig. 434 should be completed by following all applicable codes.

2. Use a non-hardening, fuel compatible thread sealant when connecting product piping to the NPT threaded fittings on the Fig. 434.

3. Seal all unused threaded openings with pipe plugs and a non-hardening, fuel compatible thread sealant.

Steps for Tightness Testing Fig. 434 Penetrations and Connections

1. Once piping and connection boots (if used) are installed perform a hydrostatic tightness test by filling the pedestal with water to a minimum of 1" above the highest penetration. Mark the level with a maker and monitor the level for a period of 1 hour or per applicable regulations.

2. If the water level drops during the test, visually identify the leak source and double check the seal at the penetration. Make repairs to the seal per manufacturer's specifications and repeat the test. If repairs do not correct leak, replace seal.

3. Be certain to properly dispose of the water used during this testing process.

Steps for Installing Emergency Shear Valve in Fig. 434

1. Insert the provided clamping bar into the channel inside the Fig.434 (see Fig.2). Install the stabilizer bar into the pedestal. Adjust the length by loosening the bar bolt and extending the bar to make contact with the channel. Screw in the clamping bar bolts without completely tightening. (see Fig.4)

2. Mount the UL Listed emergency shear valve to the stabilizer plate using 3/8" bolts. Do not tighten completely.

3. Mount the valve and stabilizer plate to the stabilizer bar using the supplied stabilizer bar u-bolts,(see Fig.2) washers, and nuts. The u-bolt will go around the stabilizer bar, and then pass through the stabilizer plate. Tighten nuts on top of washers.

4. Reinstall interchangeable pedestal top with given hardware. Make sure to use the rubber washers to seal the screw. Do not over tighten screw. Do not over tighten screw.

5. The shear valve must be aligned vertically such that the center of the shear groove is flush with the top of the pedestal. (see Fig.5) To adjust vertically loosen the bolts holding the valve to the stabilizer plate. To adjust horizontally loosen the clamping bar bolts or the 3/8" U-bolts. (see Fig.3) Tighten fasteners after adjustments have been made.

6. If the valve and dispenser inlet are not aligned, determined the distance necessary for the valve to be moved. To adjust the valve lengthwise and/or widthwise, loosen up the stabilizer u-bolts on the stabilizer bar and clamping bar bolts. Align valve to dispenser inlet.

7. If the product shear valves are positioned correctly, connect them with a union to the dispenser piping. A nipple may be required to extend the dispenser riser.

8. Make certain that piping is not abnormally stressed. Verify that the center of the shear groove on the shear valve is still level with the top of the pedestal. Retighten all the bolts, and nuts inside the pedestal. NOTE: Use provided washers.

9. Repeat these steps for each shear valve being installed.

10. Install the fuel dispenser per the manufacturer's instructions and all applicable codes.

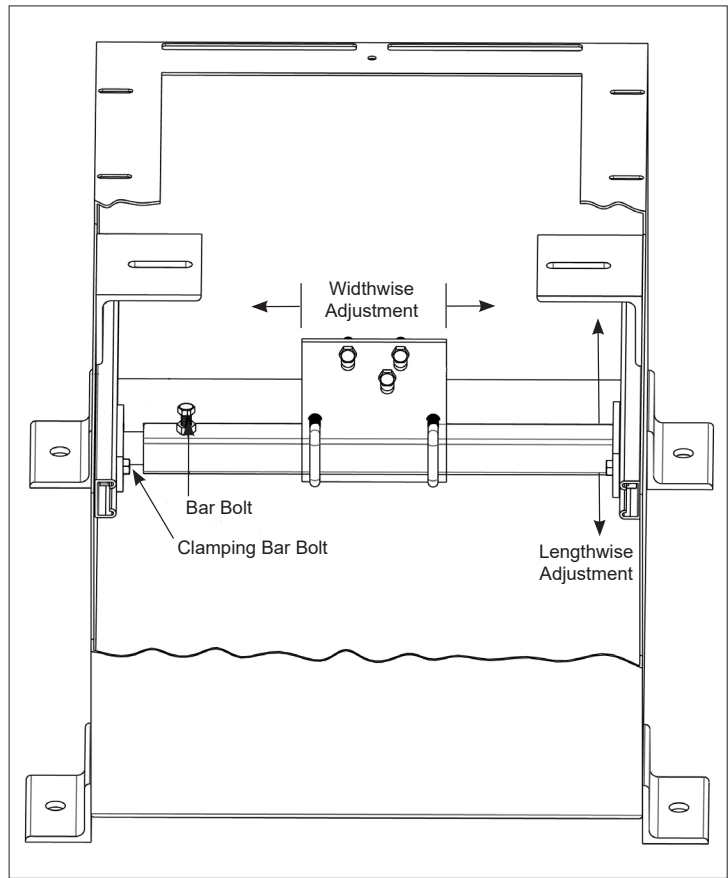

Figure 4

9. Repeat these steps for each shear valve being installed.

10. Install the fuel dispenser per the manufacturer's instructions and all applicable codes.

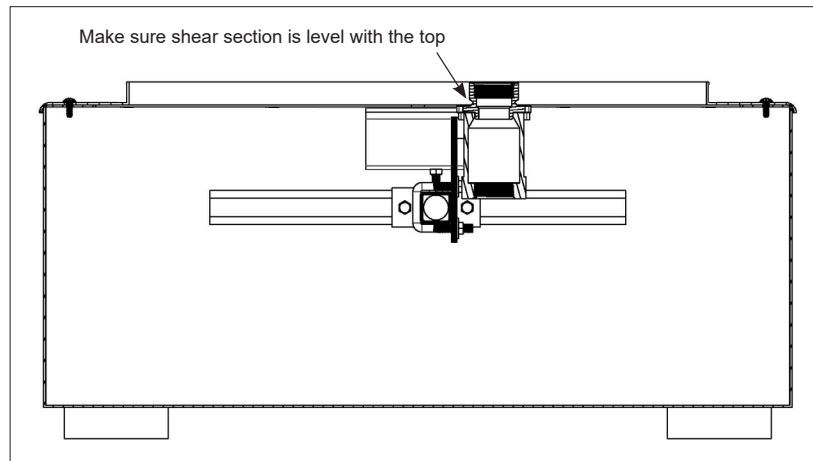

Figure 5

Maintenance



Failure to follow any or all of the warnings and instructions in this document could result in a hazardous liquid spill, which could result in property damage, environmental contamination, fire, explosion, serious injury or death.



WARNINGS

- **Fire Hazard** – Death or serious injury could result from spilled liquids or vapors that catch fire or cause an explosion.
- Fuel and vapors from fuel may be present in and all around work area. Make certain that all electric power is disabled. Only use power tools with explosion proof ratings. Avoid sparks, open flames, or hot tools when working on, in, or around the pedestal.
- Install in accordance with all applicable local, state, federal laws.
- For your safety, it is important to follow local, state, federal and/or OSHA rules that apply to working inside, above, or around the pedestal area. Use all personal protective equipment required for working in the specific environment.

Steps

1. Visual inspection of the Fig.434 and attached components must be performed on a monthly basis or in accordance with any applicable codes. Look for any type of corrosion or structural damage that might occur.
2. Any leaking or damaged components found during inspection must be repaired or replaced per the manufacturer's specifications.
3. Liquids that accumulate in the pedestal must be promptly removed and disposed of properly.

If you need any further information on applications, special configurations, approvals, etc. please consult Morrison's catalog, contact Morrison or visit our website at www.morbros.com