



LUBE KITS



PUMPS



METERS



METERED NOZZLES



NOZZLES



FILTRATION

MA 180

FEATURES

- IN/OUT SWAPPABLE
- HIGHLY DURABLE DIAPHRAGM
- BUILT-IN DIFFUSER
- SUITABLE FOR IMMERSED INSTALLATIONS
- EXPLOSION PROOF (EX ZONE 2)
- MULTI-PURPOSE PUMP
- STURDY DESIGN

The Piusi MA180 is a pneumatic diaphragm pump suitable for heavy duty uses. Thanks to its characteristics this multi-purpose pump allows for a wide range of possible installations.

PERFORMANCE

up to

40 GPM

FLOW RATE

16.4 FT

max capacity
SELF-PRIMING

max

100 PSI

AIR PRESSURE

max

Ø 0.15"

PASSING SOLID



MA 180



PACKAGING

PART #	WEIGHT		PACKAGING			
	KG	LBS	MM	INCH	PCS/PALLET	PCS/BOX
FOO208A40	8.2	18.1	270X390X400	10.6X15.4X15.7	-	1



FLUID MONITORING



HOSE REELS



AIR



ANTIFREEZE



DEF



BIODIESEL



DIESEL



FOOD



GASOLINE



GREASE



KEROSENE



OIL



WATER



WINDSCREEN

CHARTS

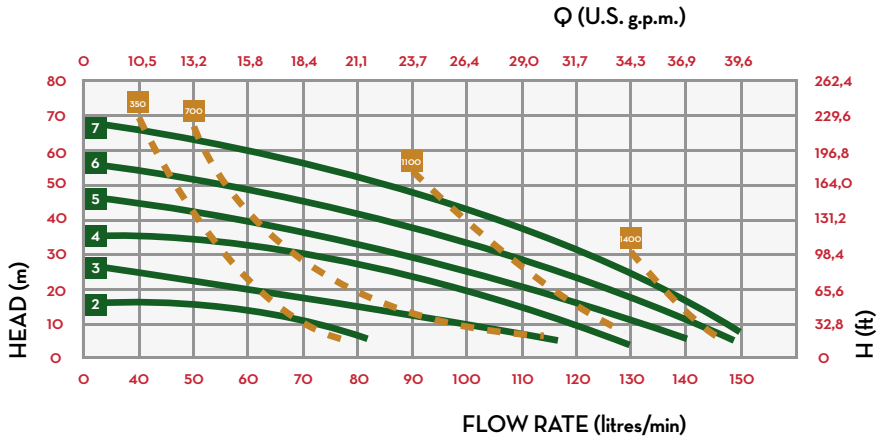

IN THE BOX

- MA PUMP
- INSTRUCTION MANUAL

DETAILS



HEAVY-DUTY MATERIALS



TECHNOPOLYMER BODY



STURDY DESIGN

DIMENSIONS

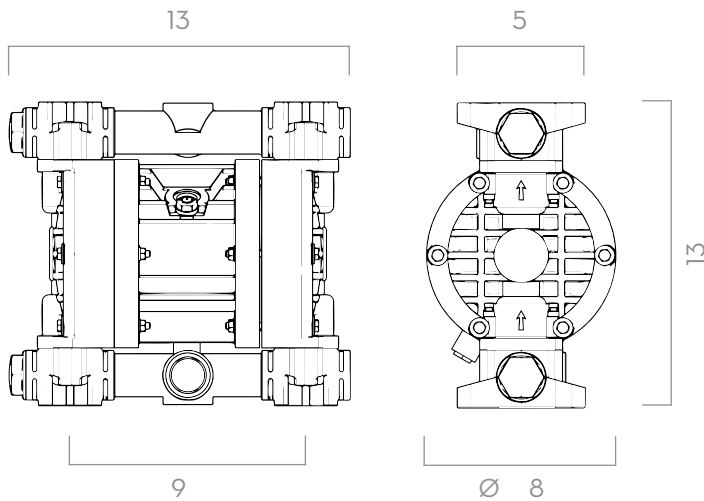

Measures expressed in inches

MATERIALS

- BODY: TECHNOPOLYMER
- FITTINGS: ALUMINUM
- DIAPHRAGMS: TECHNOPOLYMER

TECHNICAL DATA

PART #	DESCRIPTION	FLUIDS TYPE	PUMP BODY	IN / OUT	FLOW RATE GPM	MEMBRANE TYPE	DIAPHRAGM	BALLS	BALL SEATS*	O-RING*	INTAKE / DELIVERY CONNECTION	AIR CONNECTION	MAX SELF-PRIMING CAPACITY	MAX HEAD**	MAX AIR SUPPLY PRESSURE	MAX Ø OF PASSING SOLID
													FT	FT	PSI	IN
FOO208A40	MA180 DOUBLE DIAPHRAGM AIR PUMP 40GPM		ALUMINUM	1" NPT	40	DOUBLE	NBR	NBR	PPS-V	NBR	1" NPT	3/8" NPT F	16.4	230	100	0.15"

(*) ON REQUEST WE CAN PROVIDE MEMBRANES, BALLS, BALL SEATS AND O-RINGS IN DIFFERENT MATERIALS.
 (**) THE VALUE DEPENDS ON THE CONFIGURATION OF THE PUMP