



DISPENSERS



FUEL KITS



PUMPS



METERS



NOZZLE



FILTRATION

PIUSIBOX

FEATURES

- SELF PRIMING PUMP
- BUILT-IN FILTER
- EASY TO REPACK
- IP55 PROTECTION RATING

The Piusibox is a self-contained, portable diesel refueling solution packed in a protective carrying case. This handy, on-the-go transfer kit includes a 12V Bypass 3000 pump, delivery and suction hoses, manual nozzle, and the Piusi Vantage Valve which locks shut after fueling to prevent spillage. This unit also comes with a particulate filter and gloves for added equipment and user protection.

PERFORMANCE

UP TO
12 GPM

FLOW RATE

12/24V

VOLTAGE
POWER

30 MIN

ON / OFF
DUTY CYCLE



PIUSIBOX



PACKAGING

PART #	WEIGHT		PACKAGING			N. BOXES / EUROPALLET	
	KG	LBS	MM	INCH	PCS/BOX	✕	
FO023101B	12	26.5	400X300X420	16X12X17	1	24	32
FO023201B	12	26.5	400X300X420	16X12X17	1	24	32



FLUID
MONITORING



AIR



ANTIFREEZE



DEF



BIODIESEL



DIESEL



FOOD



GASOLINE



GREASE



KEROSENE



OIL



WATER



WINDSCREEN

CHART

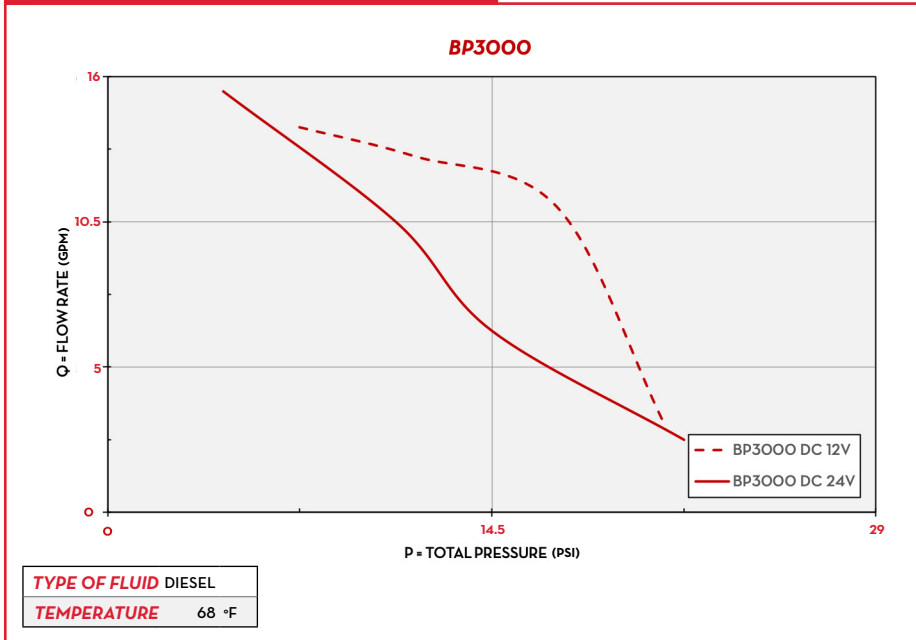

IN THE BOX

- PIUSIBOX UNIT
- SUCTION&DELIVERY HOSE
- OIL&FUEL FILTER
- CHECK VALVE
- INSTRUCTION MANUAL

DETAILS



CHECK VALVE



OIL&FUEL FILTER (pg. 94)



ROTATING CONNECTION



ERGONOMIC HANDLE

DIMENSIONS

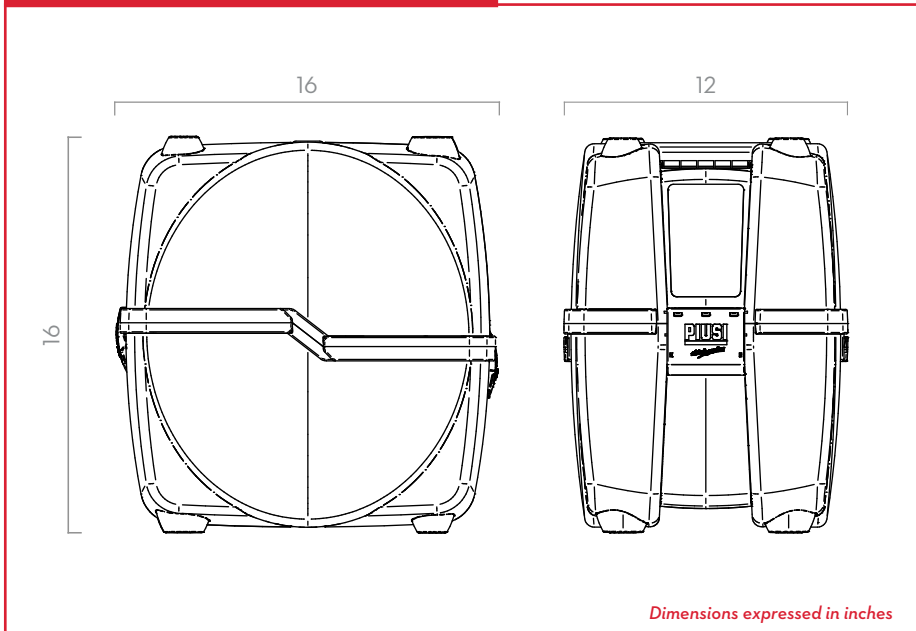

MATERIALS

- BODY: CAST IRON
- ROTOR: SINTERED STEEL
- VANES: ACETAL RESIN
- SEAL: NBR
- SHAFT: STEEL

TECHNICAL DATA

PART #	DESCRIPTION	FLUIDS TYPE	FLOW RATE		VOLTAGE			PUMP TYPE	DUTY CYCLE MINUTES	FILTER	CARTRIDGE	NOZZLE TYPE	DELIVERY HOSE 5/8"	SUCTION HOSE 3/4"	FOOT VALVE MOD. VANTAGE
			L/MIN	GPM	AC V/HZ	DC VOLT	POWER WATT								
FOO23101B	PIUSIBOX PRO 12V 12GPM (MANUAL NOZZLE)	D	43	12	24	620	26	BP 3000	30 ON/OFF	YES	10μ	MAN.	20 FT	6.5 FT	YES
FOO23201B	PIUSIBOX PRO 24V 12GPM (MANUAL NOZZLE)	D	43	12	24	620	26	BP 3000	30 ON/OFF	YES	10μ	MAN.	20 FT	6.5 FT	YES