



LUBE KITS



PUMPS



METERS



METERED NOZZLES



NOZZLES



FILTRATION

PIUSI HAND PUMP

FEATURES

- OPTIMIZED SUCTION CAPACITY
- STURDY CONNECTOR
- HEAVY-DUTY LEVER
- FLUENT REVOLUTION
- HIGH EFFICIENCY
- ADJUSTABLE SUCTION PIPE
- DURABILITY
- SELECTED MATERIALS
- 100% TESTED

The Piusi HAND PUMP is a rotary vane pump suitable for transferring low viscosity oils and diesel. Entirely designed, manufactured and certified in Italy this sturdy pump guarantees a professional performance.

PERFORMANCE

up to

10 GPM

per 100 revolutions

FLOW RATE

available with

10 FT

length

DELIVERY HOSE



HAND PUMP FOR OIL-DIESEL



PACKAGING

PART #	WEIGHT		PACKAGING			N. BOXES/ EUROPALLET	
	KG	LBS	IN	PCS/PALLET	PCS/BOX		
FO0332510	2.1	4.6	15X7X6	60	1	60	100
FO0332530	3.1	7	12X12X7	50	1	50	100



FLUID MONITORING



HOSE REELS



AIR



ANTIFREEZE



DEF



BIODIESEL



DIESEL



FOOD



GASOLINE



GREASE



KEROSENE



OIL



WATER



WINDSCREEN

CHARTS

PIUSI HAND PUMP

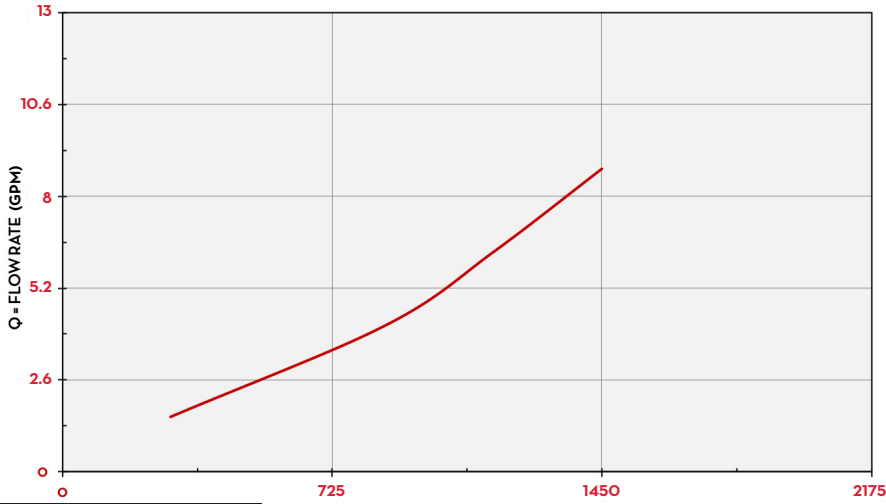

TYPE OF FLUID OIL SAE 10W40
TEMPERATURE 73°F

P = TOTAL PRESSURE (PSI)

IN THE BOX

- PIUSI HAND PUMP
- SPOUT
- INSTRUCTION MANUAL
- SUCTION PIPE
- DRUM CONNECTOR

DETAILS



HIGH QUALITY MATERIALS



NON-SLIP HANDLE

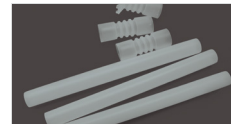

SUCTION PIPE

MATERIALS

- BODY: STAINLESS STEEL, TECHNOPYMER
- ROTOR: TECHNOPYMER
- VANES: TECHNOPYMER

DIMENSIONS

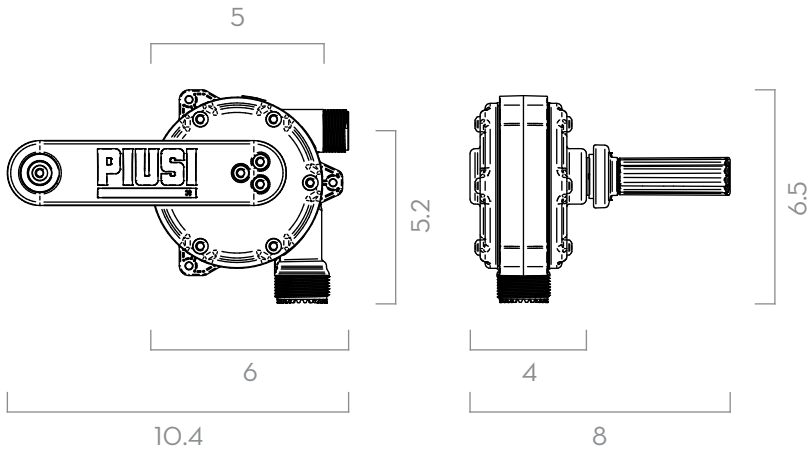

Measures expressed in inches

TECHNICAL DATA

PART #	DESCRIPTION	FLUIDS TYPE	CAPACITY PER 100 REVOLUTIONS		DRUM CONNECTOR	SUCTION TUBE	"S" SPOUT AND HOSE TAIL	DELIVERY HOSE LENGTH
			L	USG				FT
FO0332510	ROTARY HAND PUMP 2"NPT NO HOSE(FUEL&OIL)		38	10	2" NPT	INCLUDED	YES	-
FO0332530	ROTARY HAND PUMP 2"NPT W/ HOSE(FUEL&OIL)		38	10	2" NPT	INCLUDED	-	10

PIUSI HAND PUMP