



DISPENSERS



FUEL KITS



PUMPS



METERS



NOZZLE



FILTRATION

# EX75



## FEATURES

- **UL-LISTED**
- **STURDY STRUCTURE**
- **FLANGED COMPONENTS**
- **ANTI-NOISE FILTER**
- **THERMAL PROTECTION**
- **BUILT-IN BYPASS VALVE**
- **SUCTION PIPE WITH INTEGRATED FILTER**

The PIUSI EX75 PRO/BASIC KITS are complete pump transfer kits expressly engineered for UL-Certification. It is UL/CSA-Listed for operation in a Class 1, Group D area. With a 1/4 horsepower motor, and reinforced spring-loaded vanes, it is capable of a true 20 GPM flow rate at-the-nozzle.

## PERFORMANCE

<p>UP TO</p> <p><b>20 GPM</b></p> <p>AT-THE-NOZZLE</p> <p>FLOW RATE</p>	<p><b>43"</b></p> <p>LENGTH</p> <p>SUCTION PIPE</p>
<p><b>30 MIN</b></p> <p>ON AND OFF</p> <p>DUTY CYCLE</p>	<p><b>± 1%</b></p> <p>ACCURACY</p>



EX75 PRO KIT - AUTO NOZZLE + K33 METER



EX75 BASIC KIT - AUTO NOZZLE

## PACKAGING

PART #	WEIGHT		PACKAGING		
	KG	LBS	MM	INCH	PCS/BOX
<b>PRO KIT</b>					
FO037950A	7.9	17.4	356X191X267	24X16X11	1
<b>BASIC KIT</b>					
FO037851A	7.3	16.1	356X191X267	24X16X11	1
<b>PUMP ONLY</b>					
FO0378500	8	17.8	350X185X260	14X7X10	1



FLUID MONITORING



AIR



ANTIFREEZE



DEF



BIODIESEL



DIESEL



FOOD



GASOLINE



GREASE



KEROSENE



OIL



WATER



WINDSCREEN

## CHART

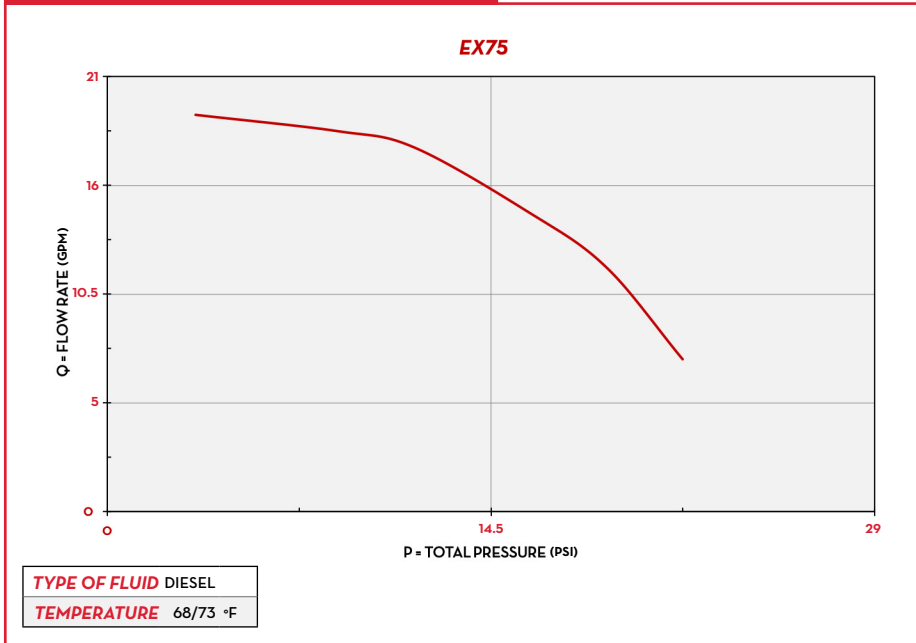

## IN THE BOX

- EX75 PUMP (12VDC ONLY)
- TELESCOPIC SUCTION PIPE
- ANTI-KINK DELIVERY HOSE
- AUTOMATIC NOZZLE
- 2" CONNECTOR
- K33 MECHANICAL METER (PRO KIT ONLY)
- INSTRUCTION MANUAL

## DETAILS



## DIMENSIONS

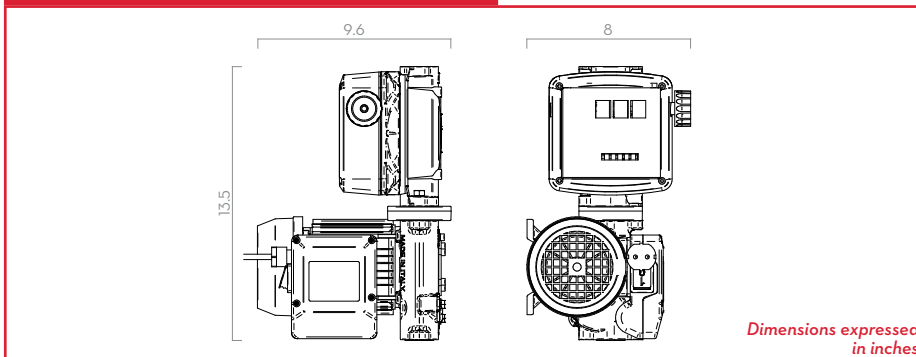

## COMPONENTS

- **METER:**  
K33 ATEX PG. 60
- **NOZZLE:**  
A120-UL PG. 86
- **FILTER:**  
WATER CAPTOR PG. 94

## TECHNICAL DATA

PART #	DESCRIPTION	FLUIDS TYPE	FLOW RATE		VOLTAGE			METER	NOZZLE	FILTER ON REQ.	INLET	HOSE	
			L/MIN	GPM	AC V/HZ	DC VOLT	POWER WATT					AMP. MAX.	TYPE
<b>PRO KIT</b>													
FO0379500	EX75 12V 20GPM FUEL PUMP PRO (AUTO/MTR)	D G K	75	20	12	250	20	K33	AUTO	YES	1"	13	3/4"
<b>BASIC KIT</b>													
FO0378510	EX75 12V 20GPM FUEL PUMP BASIC (AUTO)	D G K	75	20	12	250	20	-	AUTO	YES	1"	13	3/4"
<b>PUMP ONLY</b>													
FO0378500	EX75 12V 20GPM UL FUEL (PUMP ONLY)	D G K	75	20	12	240	20	-	-	-	1"	-	-

(\*) UPON REQUEST IT IS AVAILABLE WITH DIFFERENT VOLTAGES AND 60 HZ FREQUENCY.  
 COMPATIBLE FLUIDS: DIESEL, KEROSENE, PETROL, PETROL ALCOHOL MIXED MAX 15%, AVGAS 100/100LL, JET A/A1 - ASPEN 2/4