



DISPENSERS



FUEL KITS



PUMPS



METERS



NOZZLE



FILTRATION

EX100



FEATURES

- **UL-CERTIFIED**
- **CONTINUOUS DUTY**
- **THERMAL PROTECTION**
- **SUCTION UNIT WITH INTEGRATED FILTER**
- **HIGH FLOW RATE**

The EX100 is a UL-Classified fuel transfer pump capable of a 25 GPM flow rate at-the-nozzle. With its fan equipped motor the EX100 can operate continuously without shutting off.

PERFORMANCE

UP TO
25 GPM

FLOW RATE

AC
VOLTAGE

POWER

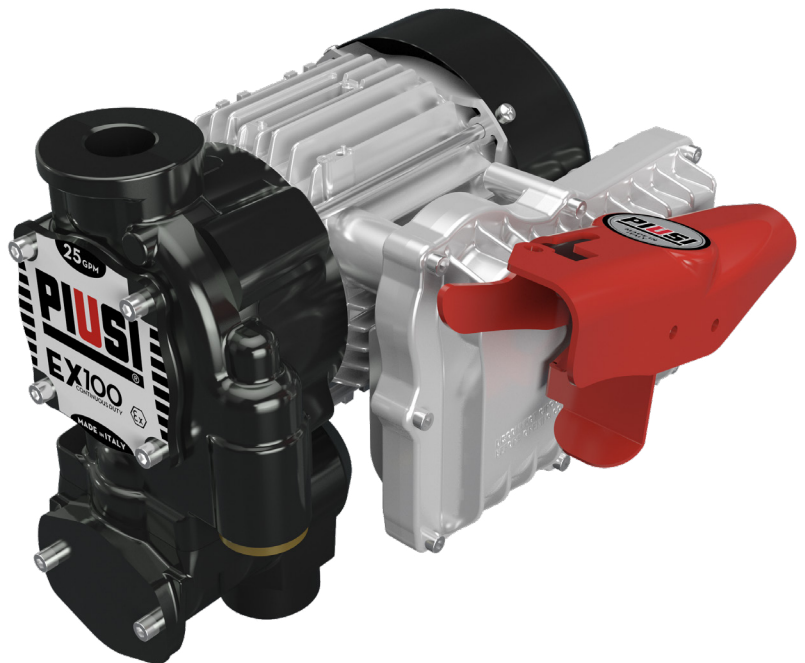

EX100



PACKAGING

PART #	WEIGHT		PACKAGING		
	KG	LBS	MM	INCH	PCS/BOX
FO0391000	25	55	240X400X390	10X16X15	1



FLUID
MONITORING



AIR



ANTIFREEZE



DEF



BIODIESEL



DIESEL



FOOD



GASOLINE



GREASE



KEROSENE



OIL



WATER



WINDSCREEN

CHART

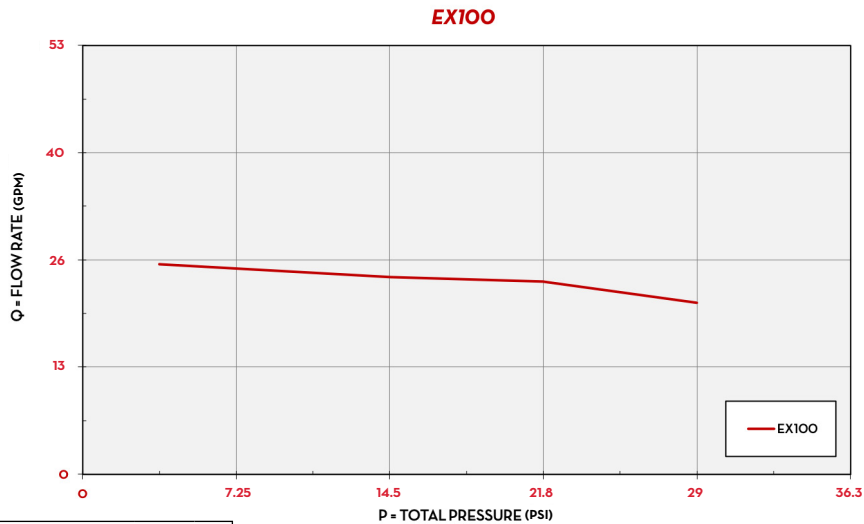

TYPE OF FLUID DIESEL

TEMPERATURE 68 °F

IN THE BOX

- EX80 / EX100 / EX140 PUMPS
- NOZZLE HOLDER
- 1" 1/4 CONNECTOR
- 90° ELBOW
- INSTRUCTION MANUAL

DETAILS

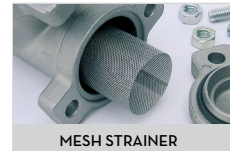

DIMENSIONS

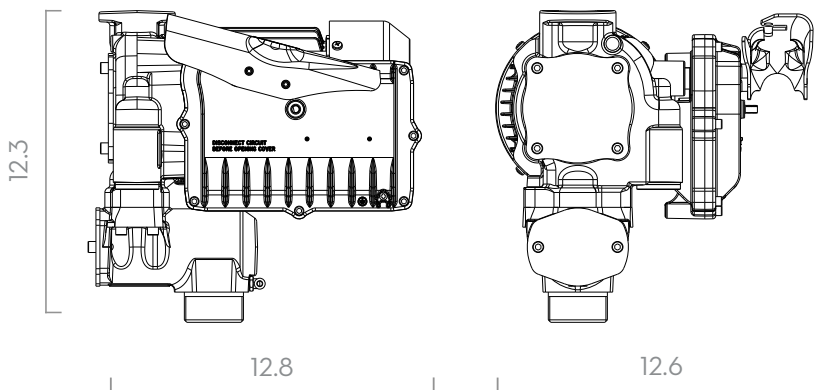

Dimensions expressed in inches

MATERIALS

- BODY: CAST IRON
- ROTOR: SINTERED STEEL
- VANES: TECHNOPOLYMER
- SEAL: VITON
- SHAFT: STEEL

TECHNICAL DATA

PART #	DESCRIPTION	FLUIDS TYPE	FLOW RATE		VOLTAGE			DUTY CYCLE	RPM	INLET		OUTLET	
			L/MIN	GPM	AC V./HZ DC VOLT	POWER WATT	AMP. MAX.	MINUTES		NPT	NPT		
FO0391000	EX100 25GPM 120V (PUMP ONLY) CONTINUOUS	D G K	100	25	120/60	900	7.5	CONTINUOUS	1450	1" 1/4	1"		

(*) UPON REQUEST IT IS AVAILABLE WITH DIFFERENT VOLTAGES AND 60 HZ FREQUENCY. IT IS RECOMMENDED THAT A 1" LINE BE USED FOR HIGH FLOW PUMPS. THIS INCLUDES ALL ACCESSORIES SUCH AS HOSE, FITTINGS, METERS, NOZZLES, ETC.

EX100