



DISPENSERS



FUEL KITS



PUMPS



METERS



NOZZLE



FILTRATION

# EX140



## FEATURES

- UL-CERTIFIED
- CONTINUOUS DUTY
- THERMAL PROTECTION
- SUCTION UNIT WITH INTEGRATED FILTER
- HIGH FLOW RATE

The most powerful pump on the market, the EX140 is the only UL-Classified fuel transfer pump with a high flow rate of up to 37 GPM at-the-nozzle. This powerhouse pump can operate continuously without shutoff because of its fan-equipped motor.

## PERFORMANCE

UP TO  
**37 GPM**

FLOW RATE

**AC**  
VOLTAGE

POWER



EX140

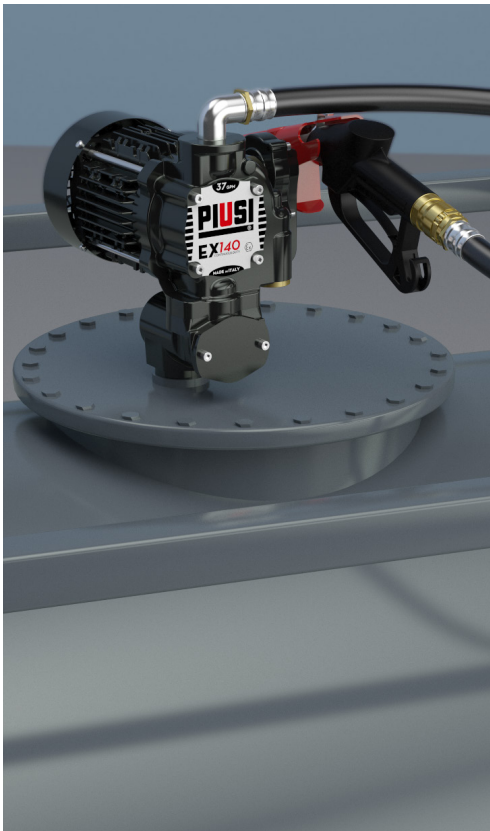

On request  
Atex  
  
II 2 G



## PACKAGING

PART #	WEIGHT		PACKAGING		
	KG	LBS	MM	INCH	PCS/BOX
FO0396000	25	55	240X400X390	10X16X15	1



FLUID  
MONITORING



AIR



ANTIFREEZE



DEF



BIODIESEL



DIESEL



FOOD



GASOLINE



GREASE



KEROSENE



OIL



WATER



WINDSCREEN

## CHART

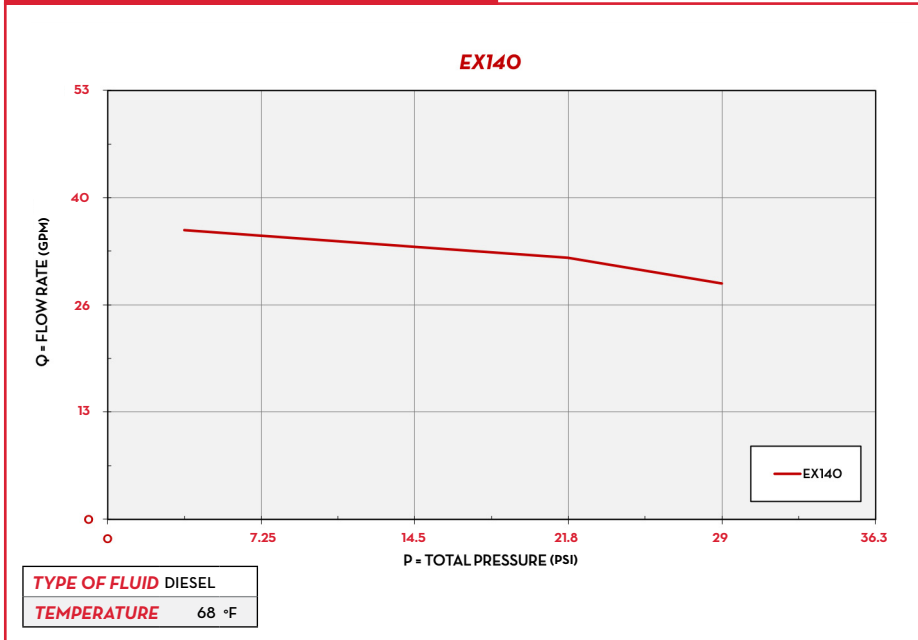

## IN THE BOX

- EX80 / EX100 / EX140 PUMPS
- NOZZLE HOLDER
- 1" 1/4 CONNECTOR
- 90° ELBOW
- INSTRUCTION MANUAL

## DETAILS

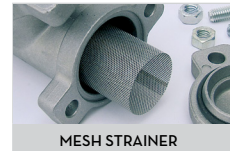

## DIMENSIONS

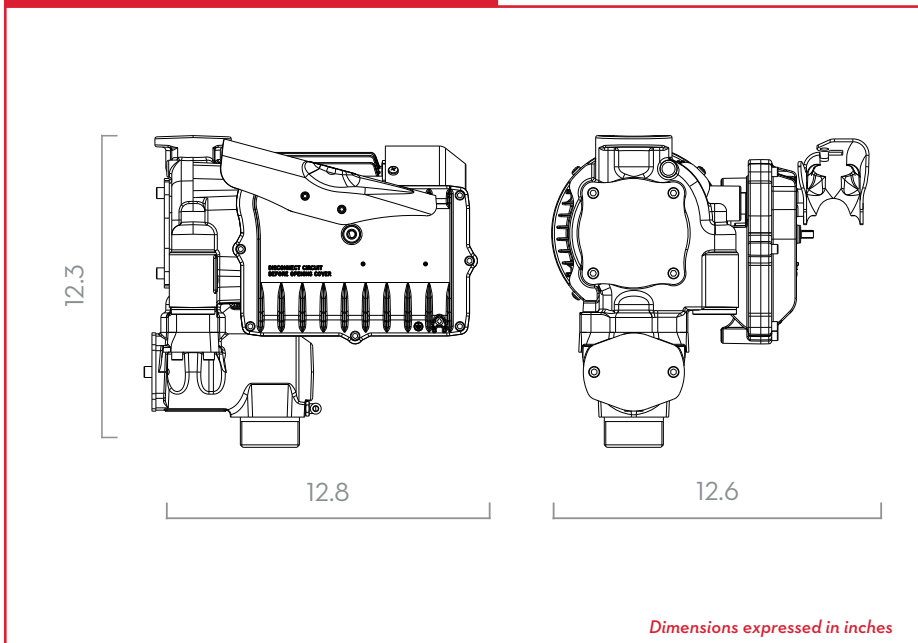

## MATERIALS

- BODY: CAST IRON
- ROTOR: SINTERED STEEL
- VANES: TECHNOPYLIMER
- SEAL: VITON
- SHAFT: STEEL

## TECHNICAL DATA

PART #	DESCRIPTION	FLUIDS TYPE	FLOW RATE		VOLTAGE			DUTY CYCLE	RPM	INLET		OUTLET	
			L/MIN	GPM	AC V./HZ	DC VOLT	POWER WATT	AMP. MAX.		MINUTES	NPT	NPT	
FO0396000	EX140 37GPM 120V (PUMP ONLY) CONTINUOUS		140	37	120/60		1080	9	CONTINUOUS	1750	1" 1/4	1"	

(\*) UPON REQUEST IT IS AVAILABLE WITH DIFFERENT VOLTAGES AND 60 HZ FREQUENCY. IT IS RECOMMENDED THAT A 1" LINE BE USED FOR HIGH FLOW PUMPS. THIS INCLUDES ALL ACCESSORIES SUCH AS HOSE, FITTINGS, METERS, NOZZLES, ETC.

# EX140