



LUBE KITS



PUMPS



METERS



METERED NOZZLES



NOZZLES



FILTRATION

# K40

## FEATURES

- SMALL SIZE
- NO BATTERY NEEDED
- EASY TO RESET
- NON-RESETTABLE TOTALIZER
- SHOCK-ABSORBING PROTECTION
- IDEAL FOR MOBILE USE
- READY TO USE
- PARTIAL AND FULL TOTALIZER
- VERSATILE

The Piusi K40 is a mechanical oval gear meter suitable for medium/high viscosity oils, without any need for calibration. It's the simplest way to measure a wide range of lubricants.

## PERFORMANCE

up to

**7.8 GPM**

from 0.26 GPM

FLOW RATE

**± 1%**

ACCURACY

**0.2%**

REPEATABILITY

up to

**2000 CST**

VISCOSITY



K40



## PACKAGING

PART #	WEIGHT		PACKAGING			N. BOXES/ EUROPALLET	
	KG	LBS	IN	PCS/PALLET	PCS/BOX		
FOO490150	0.78	1.7	6.3X4.5X5.3	-	1	126	144
FOO490160	0.78	1.7	6.3X4.5X5.3	-	1	126	144



FLUID MONITORING



HOSE REELS



AIR



ANTIFREEZE



DEF



BIODIESEL



DIESEL



FOOD



GASOLINE



GREASE



KEROSENE



OIL



WATER



WINDSCREEN

## CHARTS

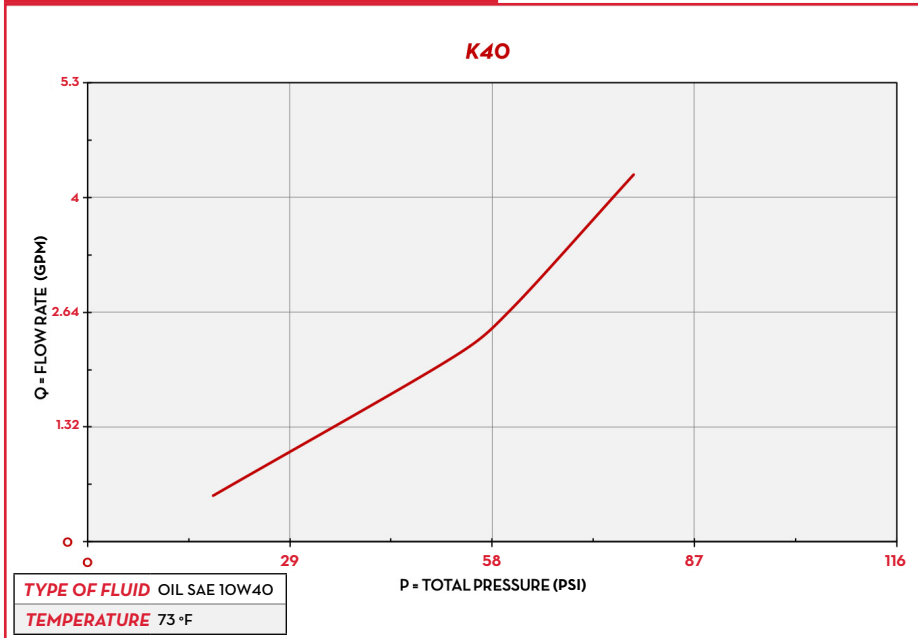

## IN THE BOX

- K40 METER
- INSTRUCTION MANUAL

## DETAILS



MECHANICAL COUNTER



TOTAL/PARTIAL RESETTING



OVAL GEAR

## MATERIALS

- BODY: ALUMINUM
- GEARS: TECHNOPOLYMER

## DIMENSIONS

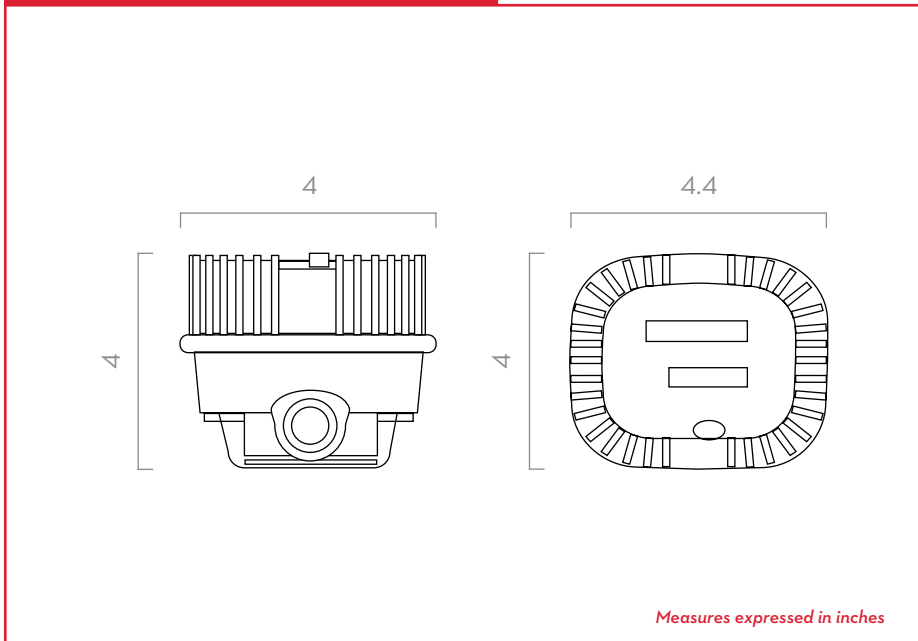

## TECHNICAL DATA

PART #	DESCRIPTION	FLUIDS TYPE	FLOW RATE		WORKING PRESSURE		INLET	OUTLET
			L/MIN	GPM	BAR	PSI		
FOO490150	K40 MECHANICAL OIL METER 1000PSI 1/2"NPT		1 - 30	0.26 - 7.8	70	994	1/2" NPT	1/2" NPT
FOO490160	K40 MECH OIL METER 1000PSI 1/2"NPT-LITER		1 - 30	0.26 - 7.8	70	994	1/2" NPT	1/2" NPT

UPON REQUEST AVAILABLE IN BSP VERSION