



DISPENSERS



FUEL KITS



PUMPS



METERS



NOZZLE



FILTRATION

K600 B/3

FEATURES

- BETTER VISIBILITY
- ADJUSTABLE FLANGES
- ROTATING DISPLAY
- STANDARD BATTERY
- PULSER VERSION AVAILABLE
- IP66 PROTECTION RATING

The PIUSI K600 B/3 is an oval gear meter suitable for monitoring the delivery of diesel, biodiesel and antifreeze. This special version includes a large 3 in. built-in digital display that can be rotated to suit every application. Among its features: 5-digit partial total and resettable total. Pulser version available.

PERFORMANCE

UP TO

26.4 GPM

FLOW RATE

0.2%

REPEATIBILITY

± 0.5%

ACCURACY



K600 B/3 METER



K600 B/3 WITH PULSE-OUT



PACKAGING

PART #	WEIGHT		PACKAGING		
	KG	LBS	MM	INCH	PCS/BOX
METERS					
FOO491040	2	4.4	200X120X140	7.9X4.7X5.5	1
PULSER					
FOO492020	2	4.4	200X120X140	7.9X4.7X5.5	1



FLUID
MONITORING



AIR



ANTIFREEZE



DEF



BIODIESEL



DIESEL



FOOD



GASOLINE



GREASE



KEROSENE



OIL



WATER



WINDSCREEN

CHART

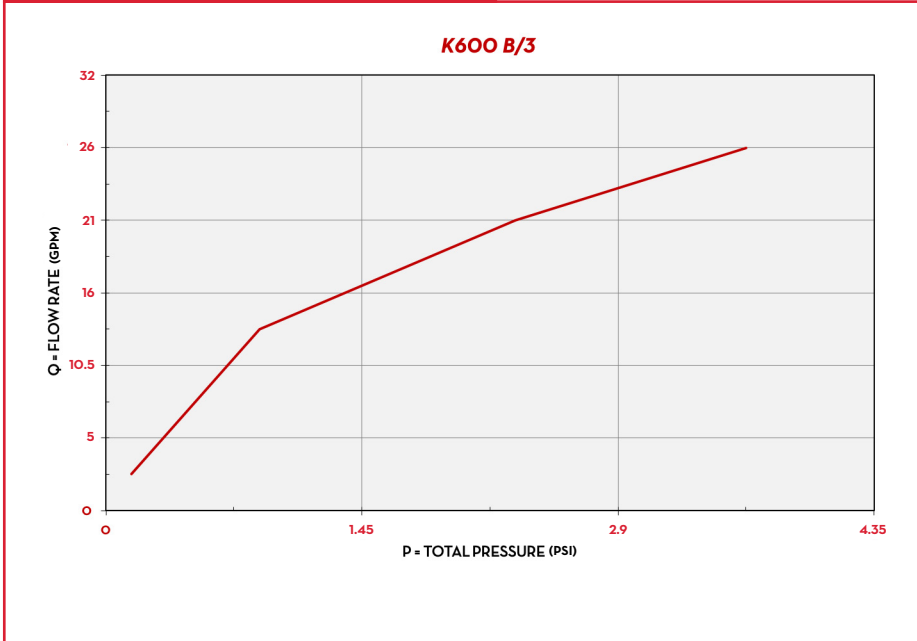

IN THE BOX

- K600 B/3 METER
- FLANGES
- INSTRUCTION MANUAL

DETAILS



5-DIGIT DISPLAY



OVAL GEARS



BIG AND ROTATING DISPLAY

DIMENSIONS

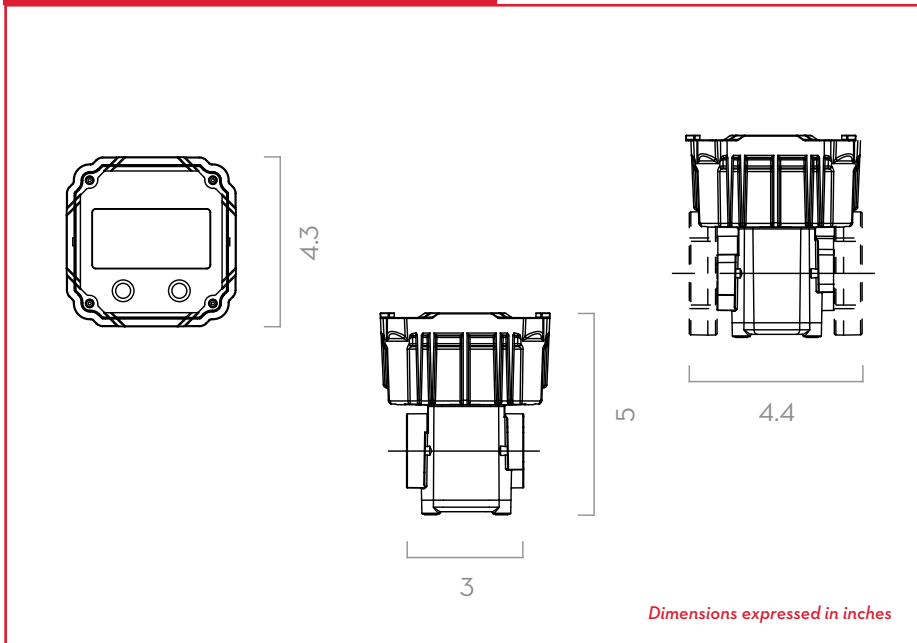

MATERIALS

- BODY: ALUMINUM
- GEARS: TECHNOPOLYMER

TECHNICAL DATA

PART #	DESCRIPTION	FLUIDS TYPE	FLOW RATE		PRESSURE		BATTERY N ^o 2 X 1.5V (INCLUDED)	FLANGE	INLET / OUTLET	INLET FILTER
			L/MIN	GPM	BAR	PSI				
METERS										
FOO491040	K600B/3 DIESEL METER 2-26GPM 1" NPT	D	10 - 100	2.64 - 26.4	30	426	YES	YES	1" NPT	YES
PULSER										
FOO492020	K600B/3 DIESEL PULSER 2-26GPM 1" NPT	D	10 - 100	2.64 - 26.4	30	426	YES	YES	1" NPT	YES

UPON REQUEST AVAILABLE IN BSP VERSION AND DISPLAY IN LITER

K600 B/3