



LUBE KITS



PUMPS



METERS



METERED NOZZLES



NOZZLES



FILTRATION

DEPUROIL

FEATURES

- IDEAL FOR DIALYSIS OF OIL
- COMPACT
- SILENT
- CLOGGING INDICATOR
- 16 FT OF CABLE
- SPIRAL TUBES

The Piusi DEPUROIL is an immediate mobile filtering unit, the easiest solution to a single step filtration suitable for any kind of tank. It includes the Piusi Viscomat Vane pump, suitable for low/medium viscosity lubricants.

PERFORMANCE

up to

6.6 GPM

TANK CAPACITY

120V

AC VOLTAGE

POWER



DEPUROIL

PACKAGING

PART #	WEIGHT		PACKAGING			
	KG	LBS	MM	INCH	PCS/PALLET	PCS/BOX
FO050301C	28	61.7	600X290X300	23.6X11.4X11.8	-	1
FO050302C	28	61.7	600X290X300	23.6X11.4X11.8	-	1



FLUID MONITORING



HOSE REELS



AIR



ANTIFREEZE



DEF



BIODIESEL



DIESEL



FOOD



GASOLINE



GREASE



KEROSENE



OIL



WATER



WINDSCREEN

CHARTS

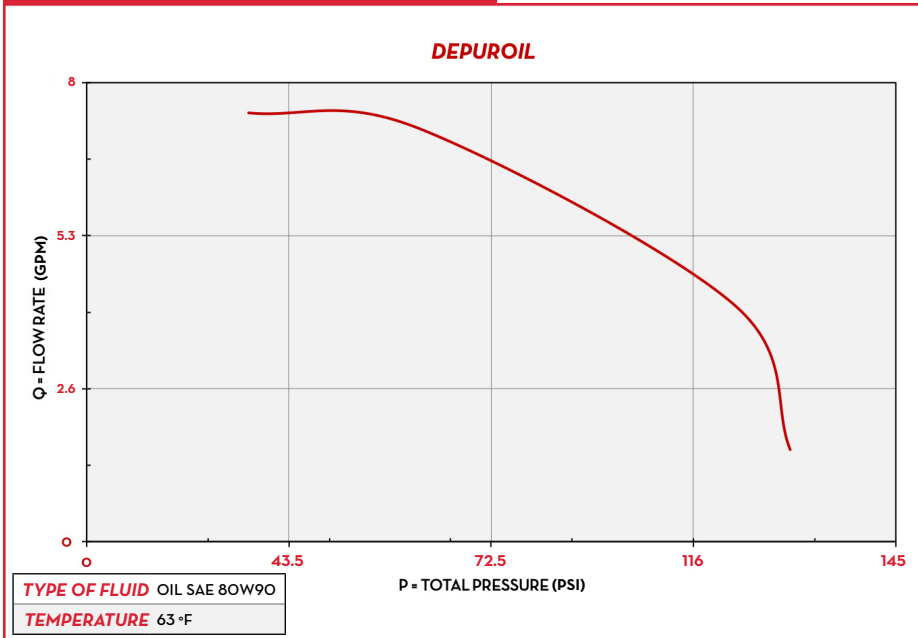

IN THE BOX

- DEPUROIL
- FILTER CARTRIDGE
- SUCTION HOSE
- DELIVERY HOSE
- INSTRUCTION MANUAL

DETAILS



LARGE DIAMETER WHEELS



STURDY STRUCTURE

DIMENSIONS

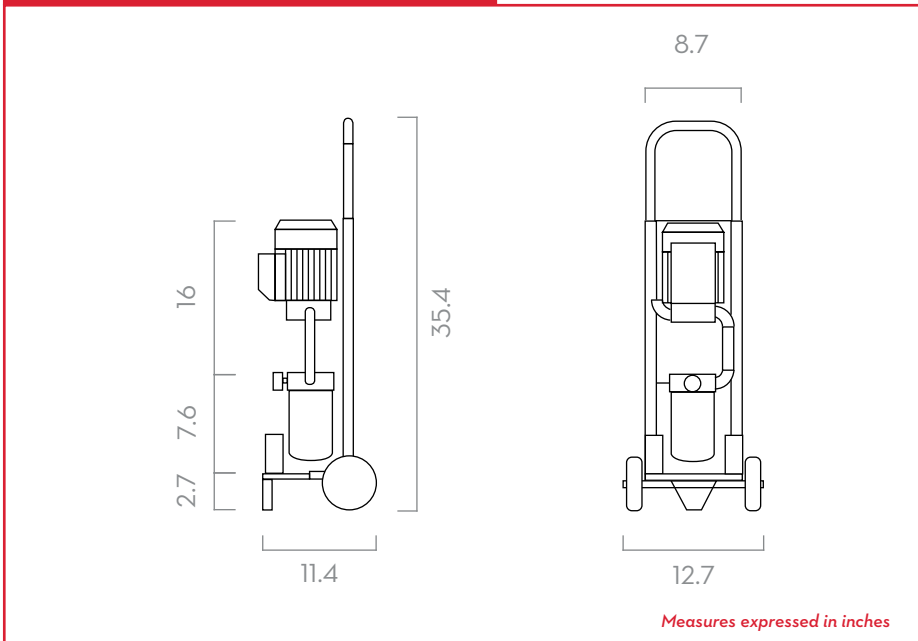

MATERIALS

- BODY: CAST IRON
- ROTOR: SINTHERED STEEL
- VAINS: TECHNOPOLYMER
- SHAFT: STEEL
- FILTER: ABSORBENT FILTERING PAPER

TECHNICAL DATA

PART #	DESCRIPTION	FLUIDS TYPE	FLOW RATE		VOLTAGE			PUMP	HOSE LENGTH		FILTERING CAPACITY
			L/MIN	GPM	AC V/HZ DC VOLT	POWER WATT	AMP. MAX.		TYPE	DELIVERY M/FT	
FO050301C	DEPUROIL 120V/60HZ		20-25	5.28-6.6	120/60	820	6.2	VISCOMAT 70	2 / 6.5	2 / 6.5	10
FO050302C	DEPUROIL 120V/50-60HZ		25	6.6	110/50 - 120/60	820/850	10-9	VISCOMAT 70	2 / 6.5	2 / 6.5	10

DEPUROIL