



DISPENSERS



FUEL KITS



PUMPS



METERS



NOZZLE



FILTRATION

# CUBE MC

## FEATURES

- MULTI-USER MANAGEMENT
- ALL-IN-ONE EQUIPMENT
- COMPACT DESIGN
- COMPATIBLE WITH SSM 2018 SOFTWARE
- SUCTION FILTER
- IP55 PROTECTION RATING

The PIUSI CUBE MC is the upgraded version of the world famous Cube dispenser equipped with an electronic panel able to manage up to 120 users and 255 transactions. The sturdy structure includes a self-priming vane pump, built-in bypass, automatic nozzle, and integrated nozzle holder with start/stop pump lever.

## PERFORMANCE

UP TO

**18 GPM**

FLOW RATE

**AC**

VOLTAGE

POWER

**± 0.5%**

ACCURACY

UP TO

**120**

USERS



CUBE 70 MC



CUBE 70 MC WITH PEDESTAL (optional)

## PACKAGING

PART #	WEIGHT		PACKAGING			N. BOXES / EUROPALLET	
	KG	LBS	MM	INCH	PCS/BOX	✈	🚚
FO059423C	25	55	381X381X482	15X15X19	1	12	24



FLUID  
MONITORING



AIR



ANTIFREEZE



DEF



BIODIESEL



DIESEL



FOOD



GASOLINE



GREASE



KEROSENE



OIL



WATER



WINDSCREEN

## CHART

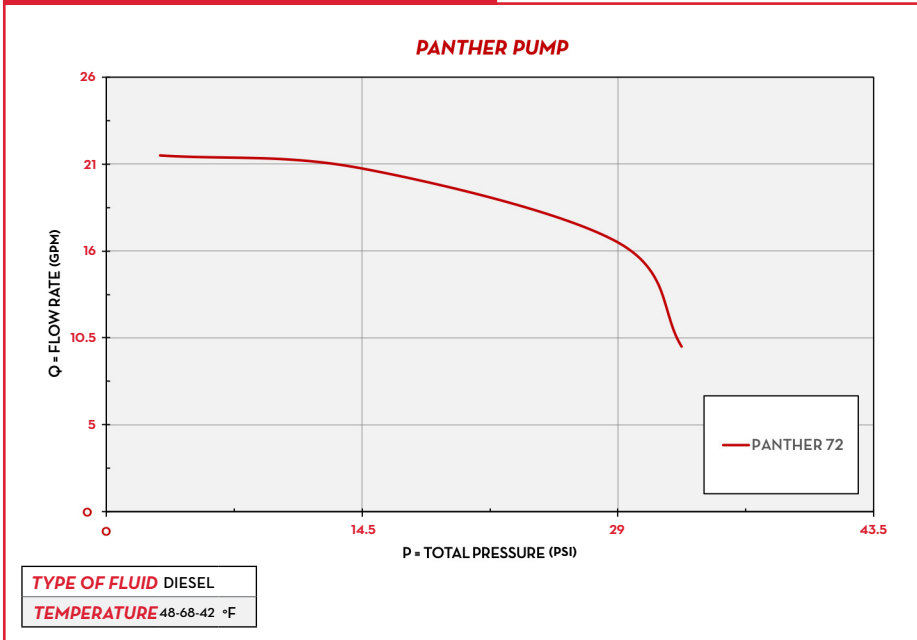

## IN THE BOX

- CUBE DISPENSER
- AUTOMATIC NOZZLE
- DELIVERY HOSE
- INSTRUCTION MANUAL

## DETAILS



## DIMENSIONS

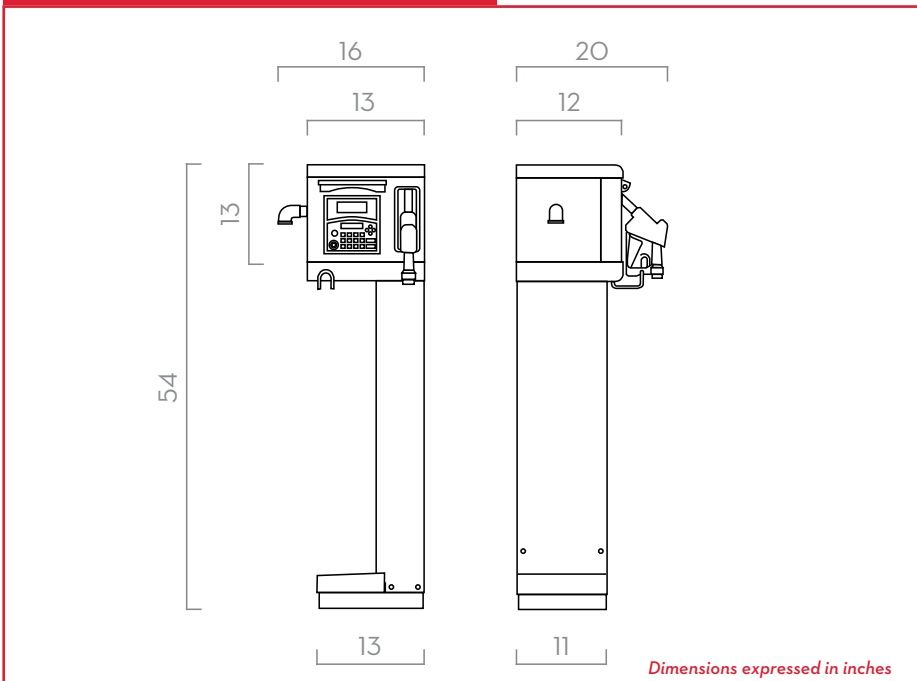

## MATERIALS

- **PUMPS:**  
PANTHER 72
- **METER:**  
K600/3 PG. 68
- **NOZZLE:**  
A60 AUTOMATIC NOZZLE PG. 86

## TECHNICAL DATA

PART #	DESCRIPTION	FLUIDS TYPE	FLOW RATE		VOLTAGE			PUMP TYPE	METER TYPE	NOZZLE TYPE	FILTER H2O FILTER	INLET NPT	HOSE		PC CONNECTION	USERS N°
			L/MIN	GPM	AC V/ HZ	DC VOLT	POWER WATT						AMP. MAX.	LENGTH		
FO059423C	CUBE 70 MC 1.0 - 120V 15GPM	D	70	18	120/60	550	5.5	PANTH 72	K600	AUTO	OPT.	1"	13 FT	1"	YES	50