



DISPENSERS



FUEL KITS



PUMPS



METERS



NOZZLE



FILTRATION

PANTHER 56

FEATURES

- COMPACT AND STURDY DESIGN
- READY TO USE
- EASY TO INSTALL
- INTEGRATED FILTER

The PIUSI PANTHER 56 is a versatile self-priming rotary electric vane transfer pump, particularly suitable for dispensers, fixed fuel transferring systems and other industrial applications. It is equipped with a by-pass valve and an incorporated filter to stop impurities.

PERFORMANCE

UP TO

15 GPM

FLOW RATE

AC

CONTINUOUS DUTY

POWER



PANTHER 56 (flanges not included)



PACKAGING

PART #	WEIGHT		PACKAGING			N. BOXES / EUROPALLET	
	KG	LBS	MM	INCH	PCS/BOX	✈	🚚
FO0730410	10	22	345X175X255	13X7X11	1	60	84



FLUID MONITORING



AIR



ANTIFREEZE



DEF



BIODIESEL



DIESEL



FOOD



GASOLINE



GREASE



KEROSENE



OIL



WATER



WINDSCREEN

CHART

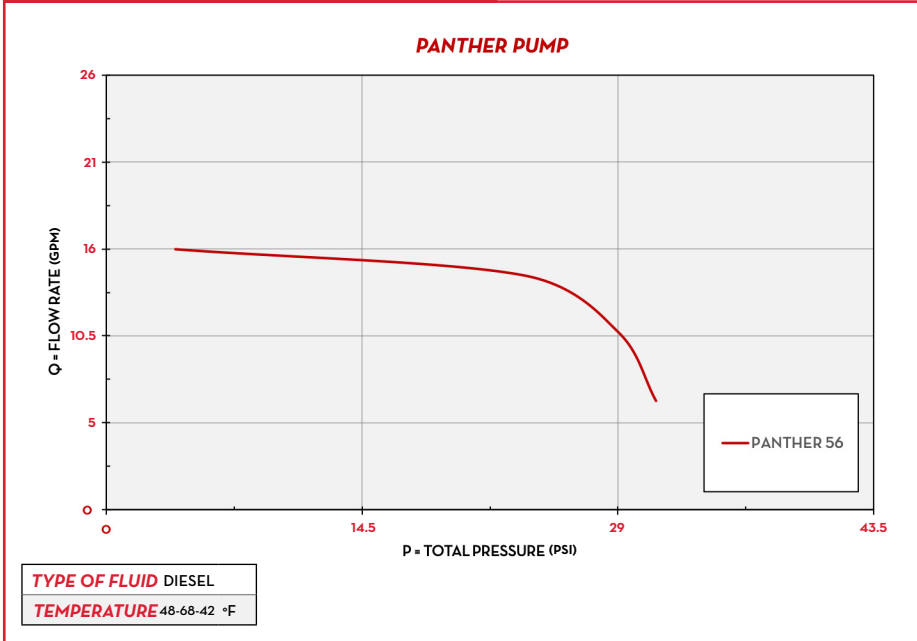

IN THE BOX

- PANTHER AC PUMP
- INSTRUCTION MANUAL

DETAILS



INTEGRATED FILTER

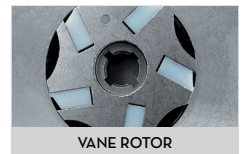

VANE ROTOR

DIMENSIONS

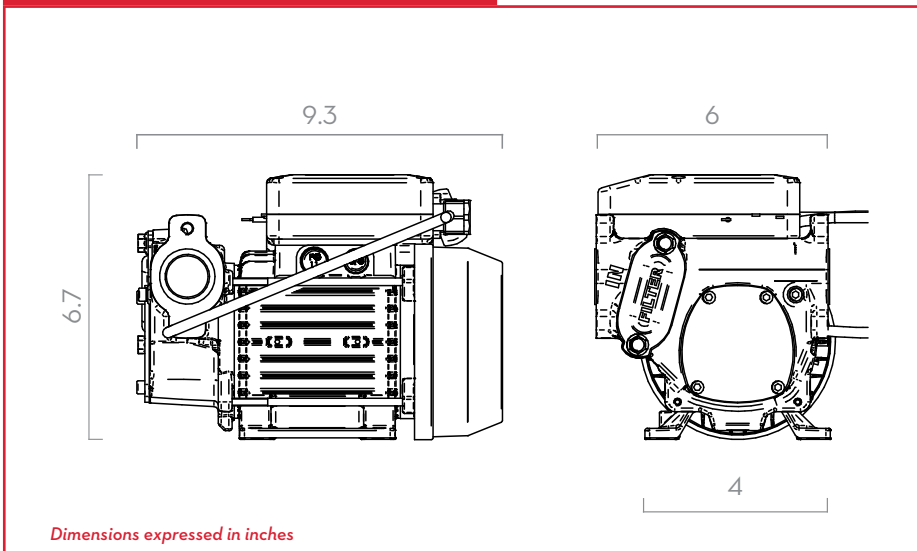

PUMP

- > MAX 6M (20FT),
- > SUCTION HOSE Ø 1" MIN,
- > MAX SUCTION HEIGHT:
 - 2M (7FT) W/O NON RETURN VALVE
 - 4M (14FT) W NON RETURN VALVE



TANK

MATERIALS

- BODY: CAST IRON
- ROTOR: SINTERED STEEL
- VANES: TECHNOPYLIMER
- SHAFT: STEEL

TECHNICAL DATA

PART #	DESCRIPTION	FLUIDS TYPE	FLOW RATE		VOLTAGE				RPM	INLET OUTLET		FLANGE CONNECTION	BYPASS VALVE	INLET FILTER
			L/MIN	GPM	SINGLEPHASE MOTOR V./HZ	THREEPHASE MOTOR V./HZ	POWER WATT	AMP. MAX.		NPT				
FO0730410	PANTHER 56 DIESEL 120V 15GPM (PUMP ONLY)	D	56	15	120/60	-	800	7.5	3400	1"	-	YES	YES	

*UPON REQUEST IT IS AVAILABLE WITH DIFFERENT VOLTAGES

PANTHER 56