



DISPENSERS



FUEL KITS



PUMPS



METERS



NOZZLE



FILTRATION

# SELF SERVICE FM

## FEATURES

- TICKET PRINTER
- MULTI-USER MANAGEMENT
- WATER CAPTOR FILTER
- TANK LEVEL INDICATOR
- STURDY STRUCTURE
- COMPATIBLE WITH SSM 2018 SOFTWARE
- IP55 PROTECTION RATING

The PIUSI SELF SERVICE FM is a dispenser for diesel with integrated OCIO tank level indicator. It is equipped with a high-capacity vane pump, built-in bypass, automatic nozzle, water captor filter and electronic panel able to manage up to 120 users and 255 transactions. It is compatible with SSM2018 software.

## PERFORMANCE

UP TO

**30 GPM**

FLOW RATE

**AC**

CONTINUOUS DUTY

POWER

**± 0.5%**

ACCURACY

UP TO

**120**

USERS



INTEGRATED TICKET PRINTER



SELF SERVICE FM

## PACKAGING

PART #	WEIGHT		PACKAGING			N. BOXES / EUROPALLET	
	KG	LBS	MM	INCH	PCS/BOX	✈	🚚
FO074204A	57	126	1080X488X400	43X19X16	1	6*	4



FLUID  
MONITORING

- A  
AIR
- A  
ANTIFREEZE
- D  
DEF
- B  
BIODIESEL
- D  
DIESEL**
- F  
FOOD
- G  
GASOLINE
- G  
GREASE
- K  
KEROSENE
- O  
OIL
- W  
WATER
- W  
WINDSCREEN

## CHART

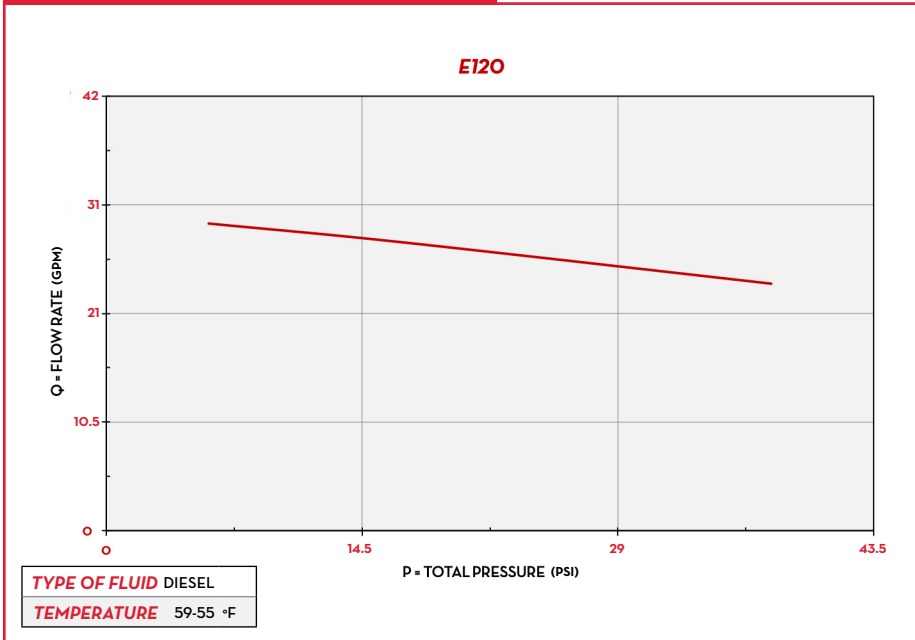

## IN THE BOX

- SELF SERVICE FM UNIT
- DELIVERY HOSE
- AUTOMATIC NOZZLE
- INSTRUCTION MANUAL

## DETAILS



## DIMENSIONS

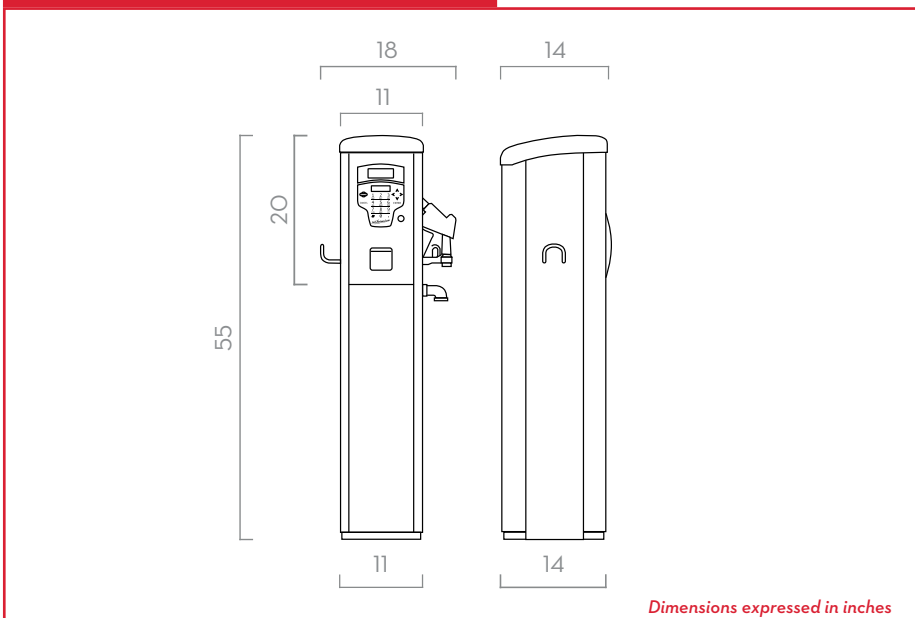

## MATERIALS

- **PUMPS:**  
E120 PG. 46
- **METER:**  
K600/3 PG. 68
- **NOZZLE:**  
A120 AUTOMATIC NOZZLE PG. 86
- **FILTER:**  
WATER CAPTOR PG. 94

## TECHNICAL DATA

PART #	DESCRIPTION	FLUIDS TYPE	FLOW RATE		VOLTAGE			PUMP	METER	NOZZLE	FILTER		INLET	PC
			L/MIN	GPM	AC V./HZ	DC VOLT	POWER WATT				AMP. MAX.	H2O FILTER		
FO074204A	SELF SERVICE FM 1.0 - 120V/60HZ 26GPM	<b>D</b>	113	30	120/60	1000	10	E120	K600	AUTO	YES	30µ	1" 1/2	YES

UPON REQUEST IT IS AVAILABLE WITH DIFFERENT VOLTAGES AND 60 HZ FREQUENCY

# SELF SERVICE FM