



LUBE KITS



PUMPS



METERS



METERED NOZZLES



NOZZLES



FILTRATION

# AIR/WATER HOSE REEL

## FEATURES

- STURDY METALLIC STRUCTURE
- ANTI-FREEZE VERSION
- BENDING PROTECTION

The Piusi OPEN HOSE REEL for Air/Water is the perfect solution to manage the dispensing of these kinds of liquids/gases. It comes with a sturdy hand protection cover to avoid any possible injury during use.

## PERFORMANCE

max

**290 PSI**

MAX WORKING PRESSURE

**50 FT**

HOSE LENGTH

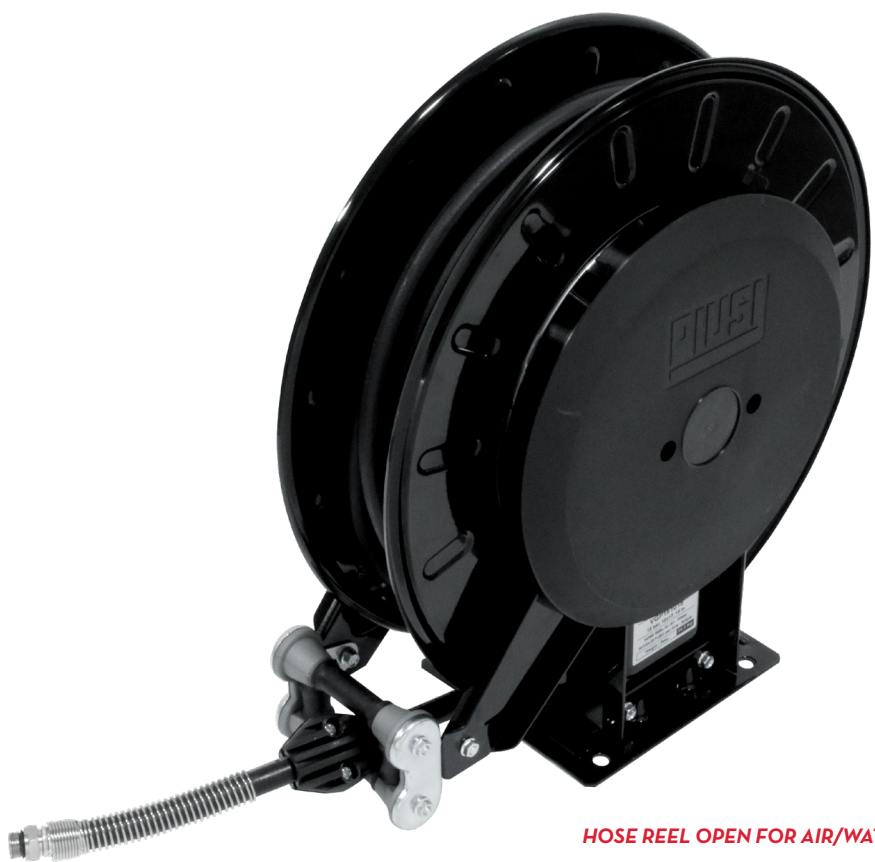

HOSE REEL OPEN FOR AIR/WATER



## PACKAGING

PART #	WEIGHT		PACKAGING			
	KG	LBS	MM	INCH	PCS/PALLET	PCS/BOX
HA201538NO	17	37.4	550X200X540	21.6X7.9X21.3	-	1



FLUID MONITORING



HOSE REELS



AIR



ANTIFREEZE



DEF



BIODIESEL



DIESEL



FOOD



GASOLINE



GREASE



KEROSENE



OIL



WATER



WINDSCREEN

## INSTALLATION

Multiple ways to install PIUSI's hose reels: they can be easily placed wherever you need them without any problem about functionality and safety. PIUSI's products are without a doubt designed to support your work in any condition.

ROOF  
INSTALLATION

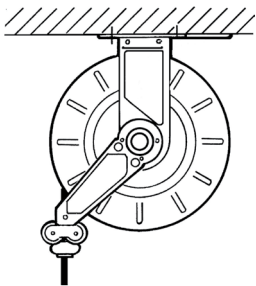

WALL  
INSTALLATION

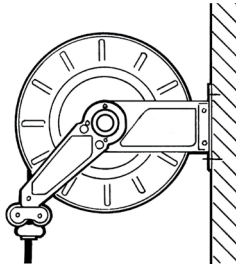

GROUND  
INSTALLATION

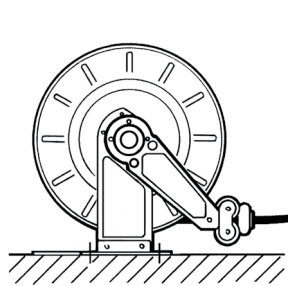

## IN THE BOX

- REEL
- WALL MOUNT BRACKET
- INSTRUCTION MANUAL
- HAND PROTECTION

## DETAILS



4 ROLLS HOSE GUIDE



STURDY DESIGN



DIFFERENT INSTALLATIONS



HAND PROTECTION

## DIMENSIONS

MODEL OPEN HOSE REEL SMALL

MODEL	OPEN HOSE REEL SMALL
A	18.7
B	18.1
C	4
D	6
E	7.7
F	6
G	6
H	0.5

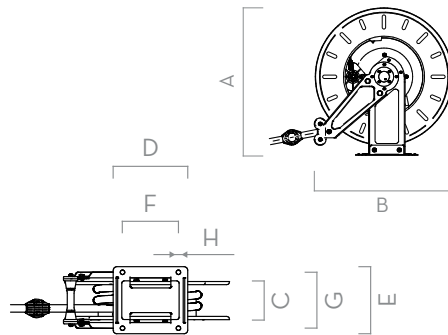

Measures expressed in inches

## MATERIALS

- BODY: CAST IRON
- HUB: SYNTHETED STEEL
- TUBE: RUBBER

## TECHNICAL DATA

PART #	DESCRIPTION	FLUIDS TYPE	HOSE (*)	MAX WORKING PRESSURE	PRESSURE DROP	INLET WITH SWIVEL	OUTLET HOSETAIL	HOSE MAX LENGTH BOUND	HOSE LENGTH
			NPT/BSP	PSI	BAR	NPT/BSP	NPT/BSP	FT	FT
HA201538NO	OPEN HOSE REEL AIR/WATER 3/8" X 50FT NPT		3/8"	290	-	3/8" FEMALE	3/8" FEMALE	-	50

# AIR/WATER HOSE REEL

OPEN